





























































































































ETERNA
SOLUTIONS

HINGES





HINGE SERIES

										
CL103	CL104	CL105	CL106	CL108	CL109	CL111-2	CL115	CL116	CL117	CL119
										
CL121	CL123	CL124	CL125	CL126	CL127	CL128	CL132	CL133	CL135	CL137
										
CL138	CL139	CL142	CL145	CL148	CL150	CL152	CL152-2	CL154	CL156	CL158
										
CL158-2	CL163	CL167	CL173	CL178	CL201-1	CL202-1	CL203-1	CL203-2	CL203-4	CL204-1
										
CL204-3	CL204-3S	CL204-3F	CL205-1	CL206-1	CL207	CL208	CL210	CL209	CL211	CL212
										
CL213-1	CL214	CL215	CL218	CL219	CL220	CL221	CL222	CL223	CL225-3	CL225-5
										
CL226	CL226-1K	CL226-8	CL228	CL229-2A	CL230	CL231-1	CL232	CL233	CL234	CL235
										
CL237	CL237-3	CL238	CL240-1	CL244	CL246	CL247	CL248	CL249	CL250-1	CL250-6
										
CL251	CL253-1	CL253-2	CL253-5	CL253-6	CL253-9	CL253-10	CL254	CL257	CL260	CL261
										
CL263	CL264	CL266	CL268	CL269	CL272	CL273	CL274	CL275-1	CL276	CL280
										
CL281	CL282-1	CL283	CL289	CL290	CL293	CL295	CL296	CL297	CL331	CL332

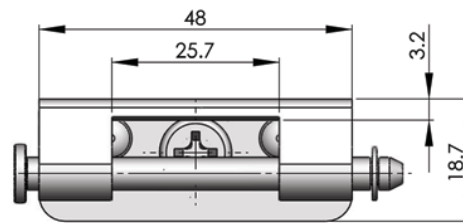
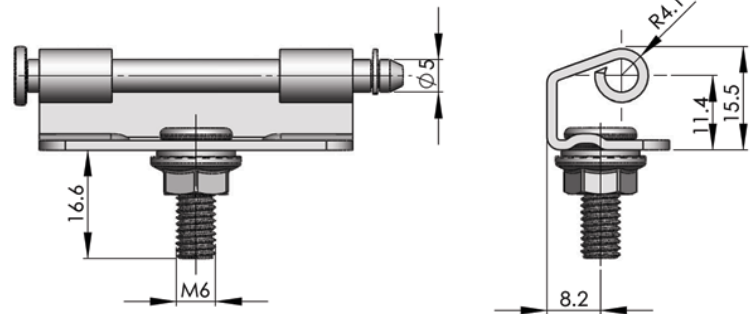
Accessories	<p>CL103</p> 
Electronic lock	
Handle lock	
Cylinder lock	
Plane lock	
Rod control lock	 <p>Main material: steel hinge and pin Finish: yellow zinc plated</p> <p>Performance parameter: Maximum static load Radial load: 310N Axial load: 155N</p>



ERP CL103F3C001

Panel lock	<p>CL104</p> 
Toggle and hook	
Handles	
Door stop	
Hinge	
Seal gasket	 <p>Main material and finish: Black powder coated ZDC hinge and stainless steel pin Application: Opening angle 180°</p> <p>Performance parameter: Maximum static load Radial load: 405N Axial load: 805N</p>

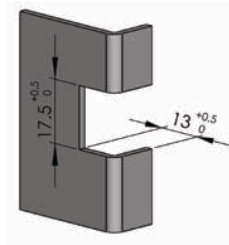
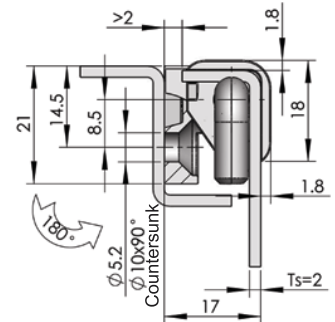
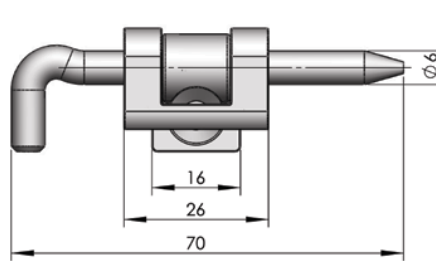

Door cutout

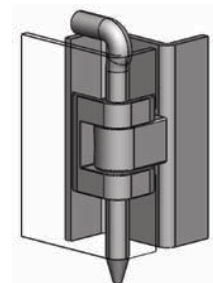

ERP CL104Z1A001

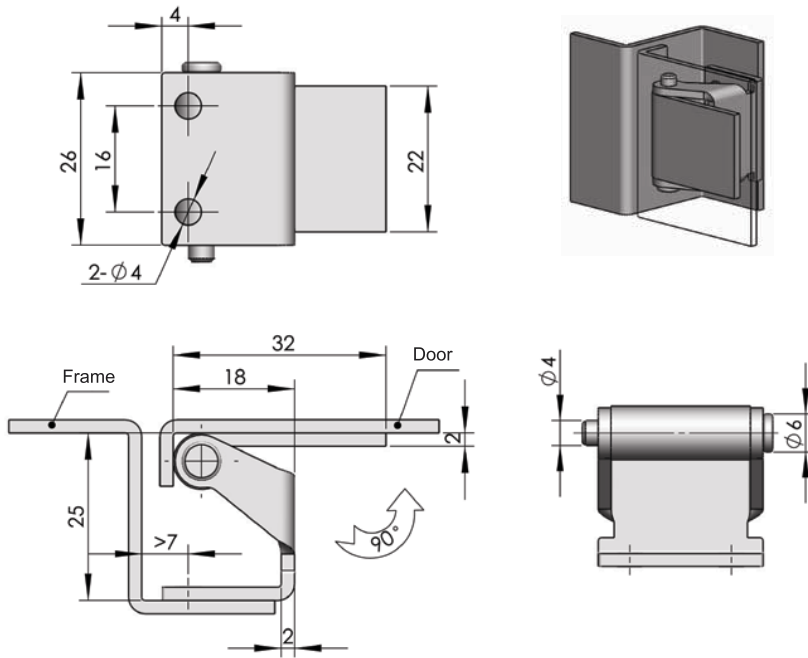

ERP

CL105F3D001

CL105



Main material and finish: 3+ zinc plated steel hinge and pin
Application: Opening angle 180°

Performance parameter:
Maximum static load
Radial load: 60N
Axial load: 120N

Accessories

Electronic lock

Handle lock

Cylinder lock

Plane lock

Rod control lock

Panel lock

Toggle and hook

Handles

Door stop

Hinge

Seal gasket

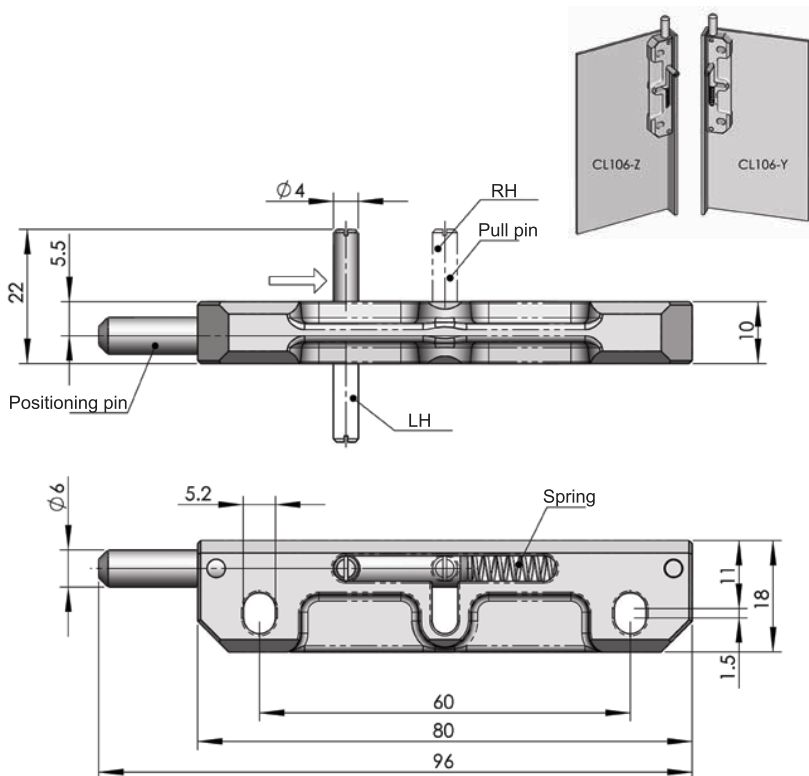

ERP

CL106Z3I001

CL106



Main material and finish: Sand-spraying and nickel plated ZDC hinge, stainless steel shaft and spring
Application: By changing the direction of pin to realise the shift between LH and RH

Performance parameter:
Maximum static load
Radial load: /N
Axial load: 645N

Accessories
Electronic lock
Handle lock
Cylinder lock
Plane lock
Rod control lock
Panel lock
Toggle and hook
Handles
Door stop
Hinge
Seal gasket

CL108



Main material and finish: Black PA hinge, and nickel plated stainless steel pin
Application: Opening angle 180°

Performance parameter:
Maximum static load
Radial load: 800N
Axial load: 600N

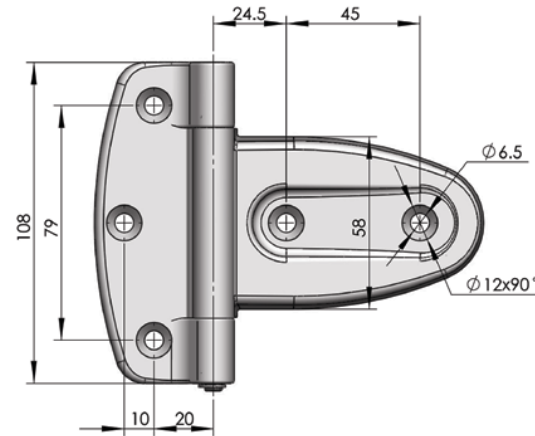
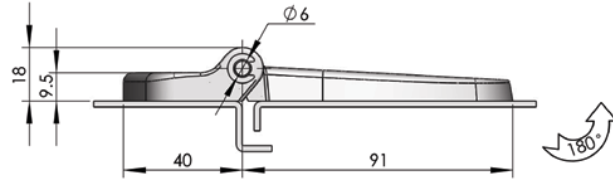

ERP

CL108N00001

CL108-2



Main material: steel hinge
Finish: black powder coated
Application: Opening angle 180°

Performance parameter:
Maximum static load
Radial load: 3000N
Axial load: 3000N

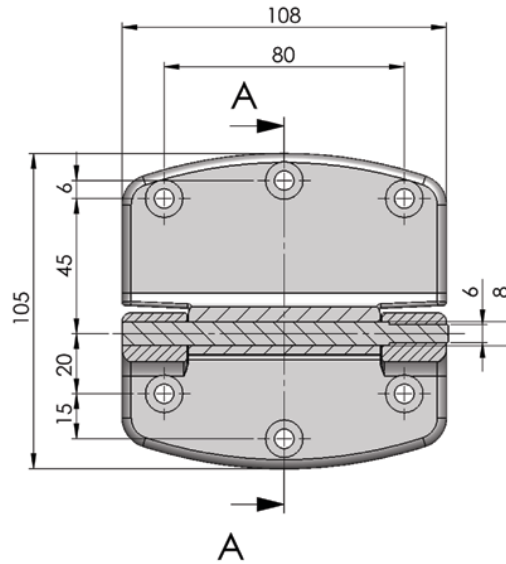

Section A-A

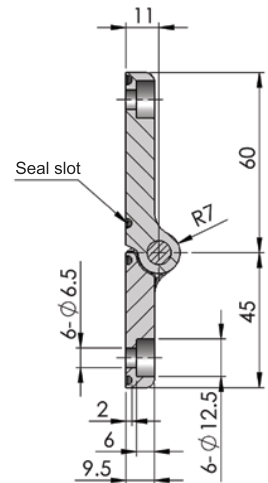

ERP

CL108F1A001

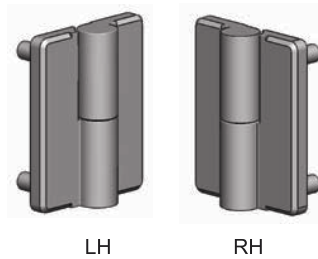
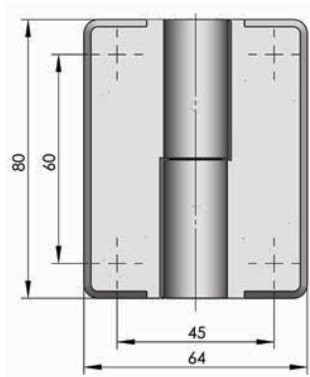
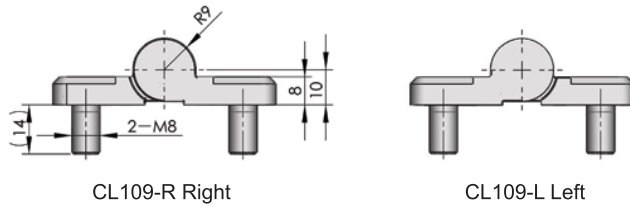

	CL109-Z Left hinge	CL109-Y Right hinge
ERP	CL109Z1A002	CL109Z1A001

CL109



Main material and finish: Black powder coated ZDC hinge and stainless steel screw

Application: Opening angle 180°

Performance parameter:

Maximum static load

Radial load: 2500N

Axial load: 2500N

Accessories

Electronic lock

Handle lock

Cylinder lock

Plane lock

Rod control lock

Panel lock

Toggle and hook

Handles

Door stop

Hinge

Seal gasket

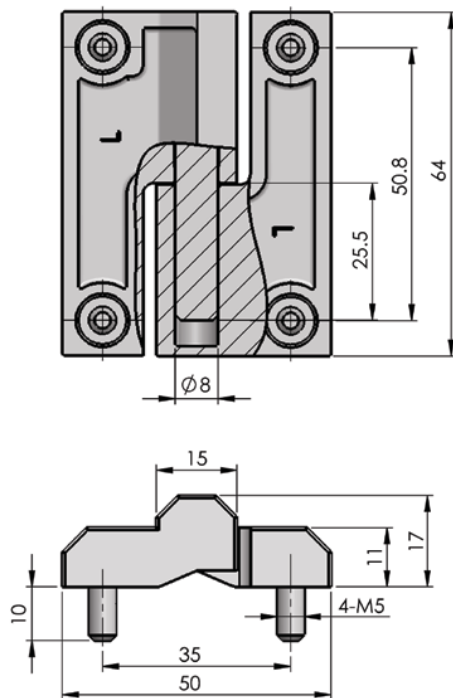

ERP	CL109Z1B001
-----	-------------

CL109-2



Main material: ZDC hinge, stainless steel pin, PTFE gasket

Finish: black powder coated

Performance parameter:

Maximum static load

Radial load: 1800N

Axial load: 1600N

CL111

Accessories

Electronic lock

Handle lock

Cylinder lock

Plane lock

Rod control lock

Main material and finish: 3+ zinc plated ZDC hinge and stainless steel pin
 Application: When the gap between door and frame is 3mm, opening angle 110°

Performance parameter:
 Maximum static load
 Radial load: 775N
 Axial load: 1000N

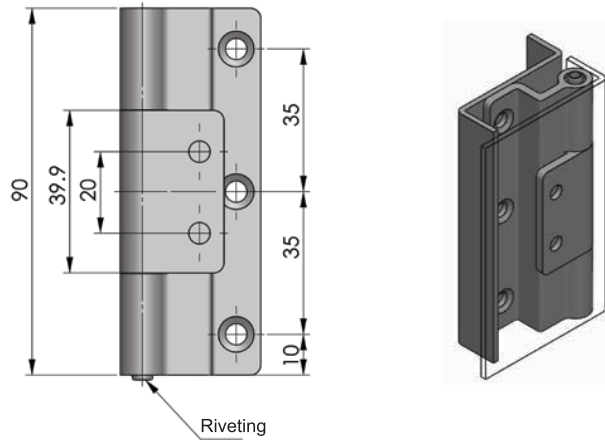
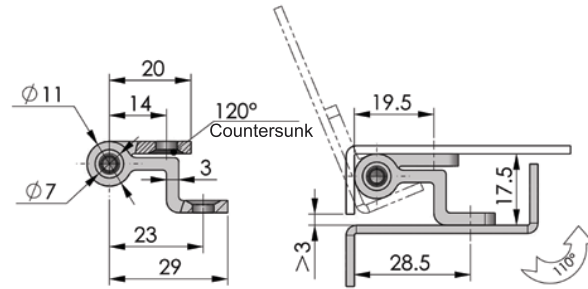

ERP CL111Z3D001

CL111-2

Panel lock

Toggle and hook

Handles

Door stop

Hinge

Seal gasket

Main material and finish: steel hinge, stainless steel pin
 Application: opening angle 180°
 Finish: soak anti-rust oil

Performance parameter:
 Maximum static load
 Radial load: 1500N
 Axial load: 2000N

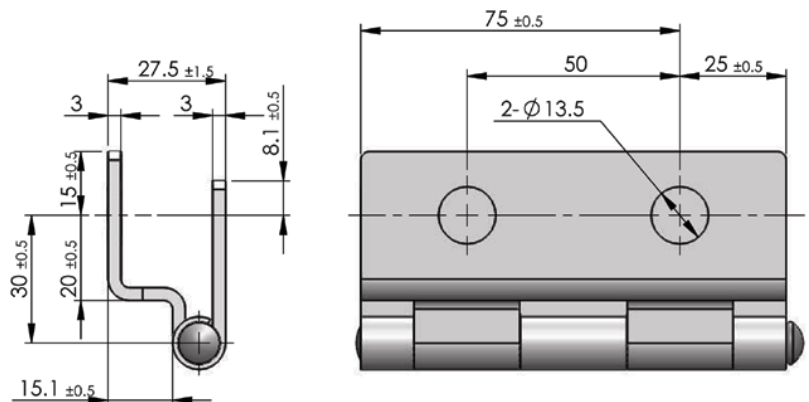

ERP CL111F00001

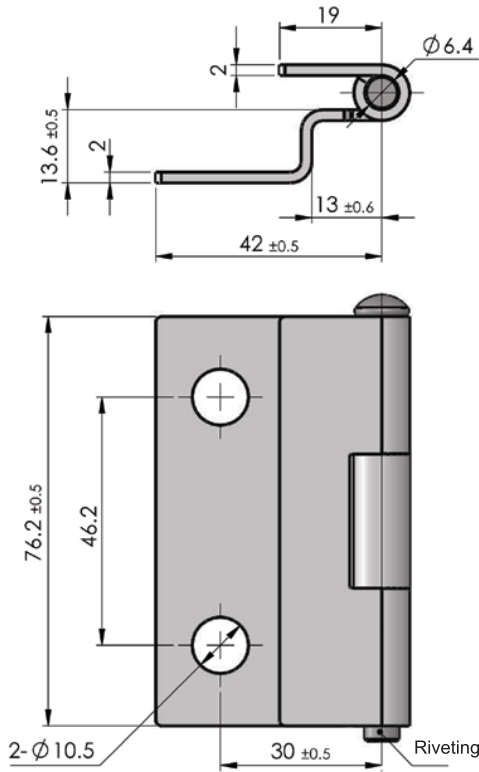

ERP

CL111F00004

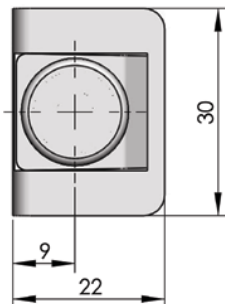
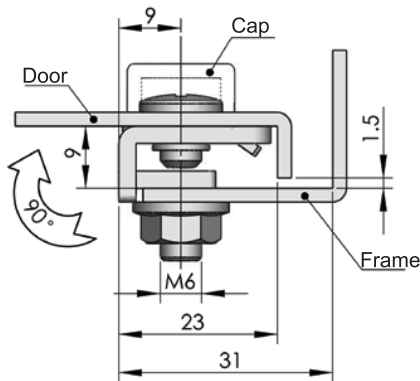

ERP

CL114F3D001

CL111-3-1D



Main material and finish: steel hinge, stainless steel pin
Application: opening angle 180°
Finish: soak anti-rust oil

Performance parameter:
Maximum static load
Radial load: 450N
Axial load: 2000N

CL114



Main material and finish: 3+ zinc plated steel hinge
Application: Opening angle 90°

Performance parameter:
Maximum static load
Radial load: 110N
Axial load: 105N

Accessories

Electronic lock

Handle lock

Cylinder lock

Plane lock

Rod control lock

Panel lock



Toggle and hook

Handles



Door stop

Hinge

Seal gasket

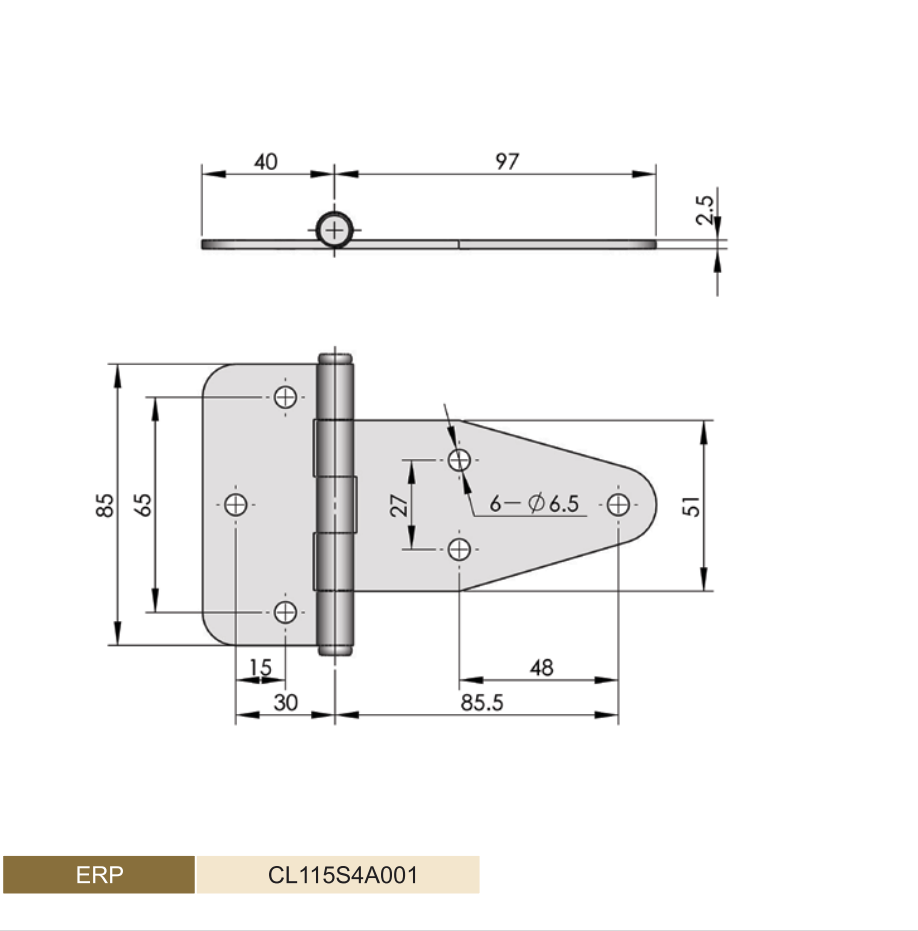
Accessories	<p>CL115</p> 
Electronic lock	
Handle lock	
Cylinder lock	
Plane lock	
Rod control lock	 <p>Main material and finish: Mirror polishing stainless steel hinge Application: Opening angle 180°</p> <p>Performance parameter: Maximum static load Radial load: 530N Axial load: 800N</p>



Panel lock	<p>CL116</p> 
Toggle and hook	
Handles	
Door stop	
Hinge	
Seal gasket	 <p>Main material and finish: Black powder coated ZDC hinge and steel shaft Application: Opening angle 180°</p> <p>Performance parameter: Maximum static load Radial load: 1000N Axial load: 450N</p>

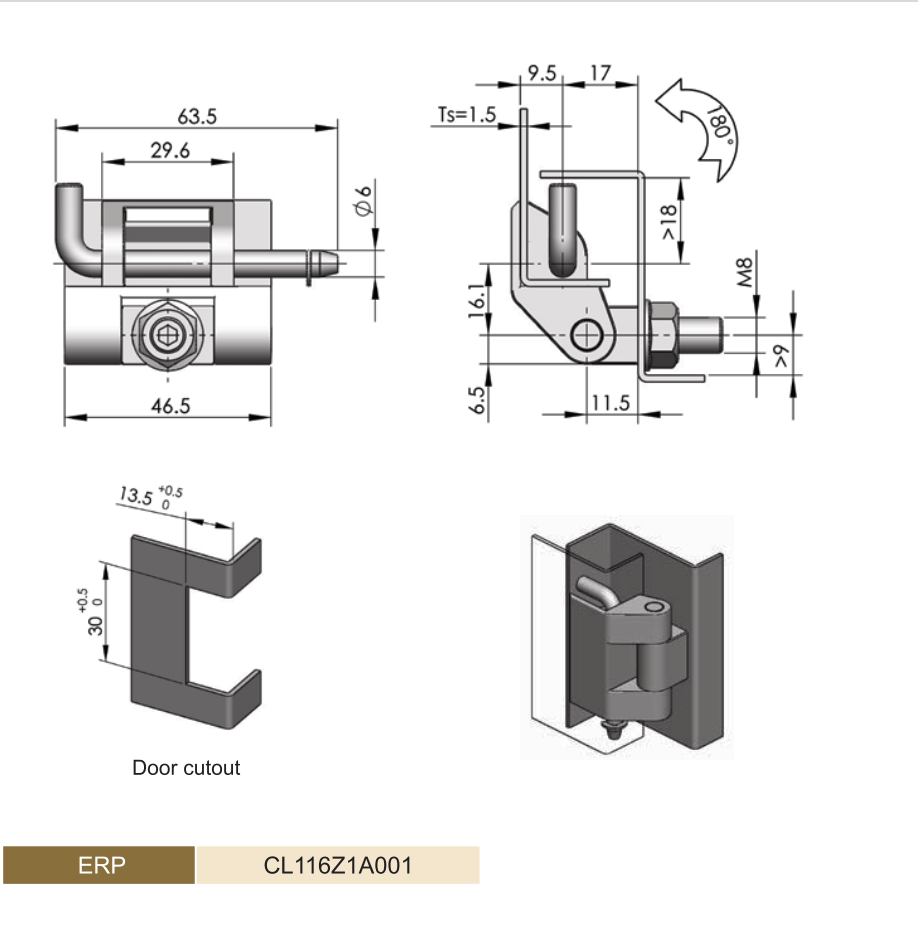

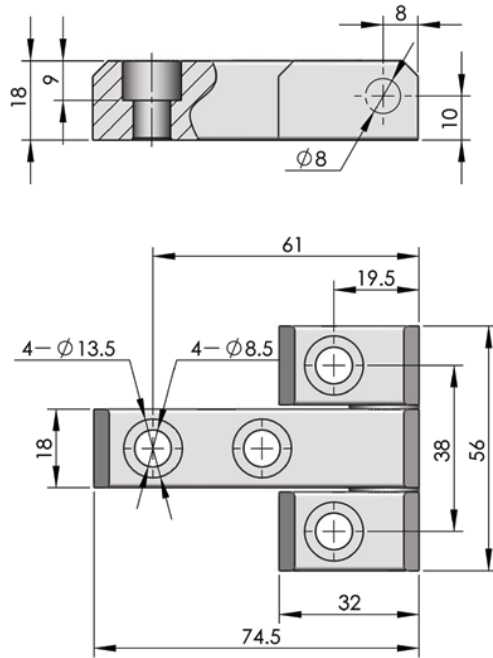

ERP

CL117F3D001

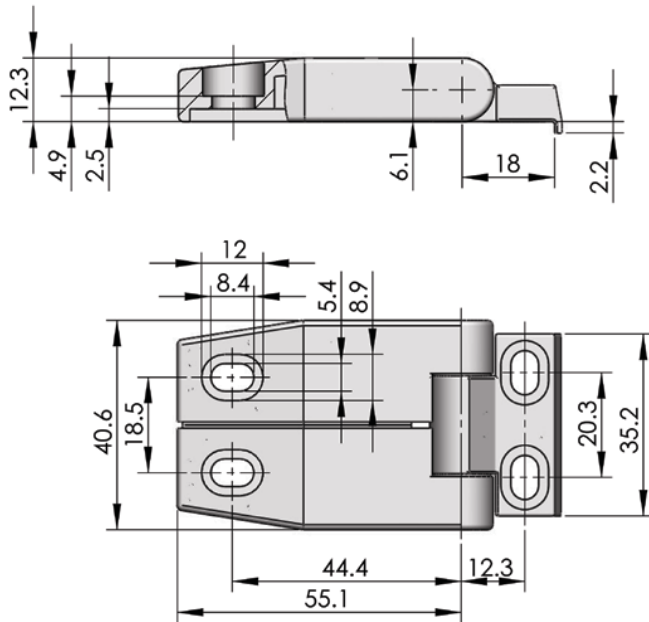

ERP

CL119Z1B001

CL117



Main material and finish: White zinc-plated steel hinge and shaft

Performance parameter:

Maximum static load

Radial load: 3000N

Axial load: 3000N

CL119



Main material and finish: Black powder coated ZDC hinge and nickel-plated steel shaft

Performance parameter:

Maximum static load

Radial load: 280N

Axial load: 930N

Accessories

Electronic lock

Handle lock

Cylinder lock

Plane lock

Rod control lock

Panel lock

Toggle and hook

Handles

Door stop

Hinge

Seal gasket

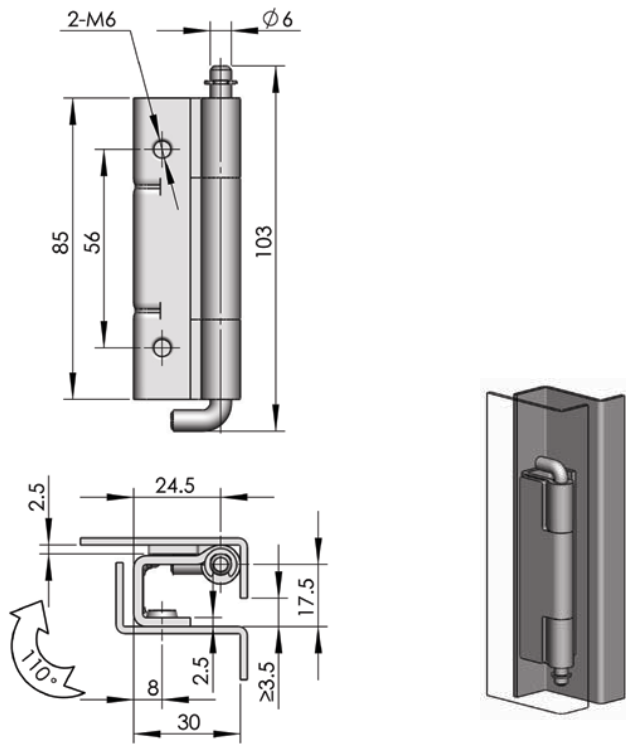

ERP CL125F3D001

CL125



Main material and finish: White zinc-plated steel hinge and pin
 Application: Opening angle 110°

Performance parameter:
 Maximum static load
 Radial load: 450N
 Axial load: 850N

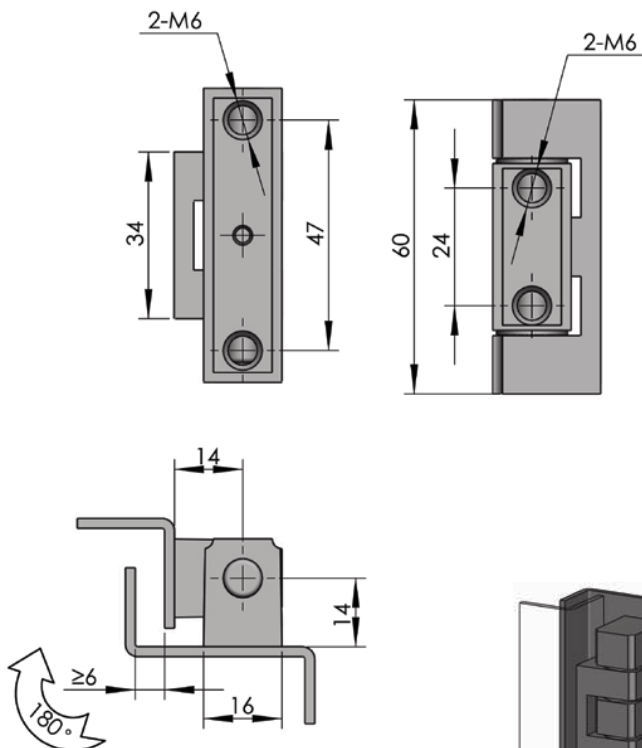

ERP CL126F3A001

CL126



Main material and finish: Bright chrome-plated ZDC hinge and nickel-plated steel shaft
 Application: Opening angle 180°

Performance parameter:
 Maximum static load
 Radial load: 1290N
 Axial load: 1600N

Accessories
Electronic lock
Handle lock
Cylinder lock
Plane lock
Rod control lock
Panel lock
Toggle and hook
Handles
Door stop
Hinge
Seal gasket

- Accessories
- Electronic lock
- Handle lock
- Cylinder lock
- Plane lock
- Rod control lock
- Panel lock
- Toggle and hook
- Handles
- Door stop
- Hinge
- Seal gasket



CL127-1
CL127-2



Main material and finish: Mirror polishing stainless steel hinge and pin
Application: Opening angle 180°

Performance parameter:
Maximum static load
Radial load: 3145N
Axial load: 3000N

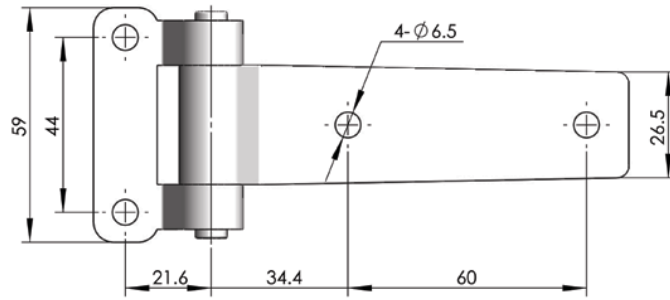
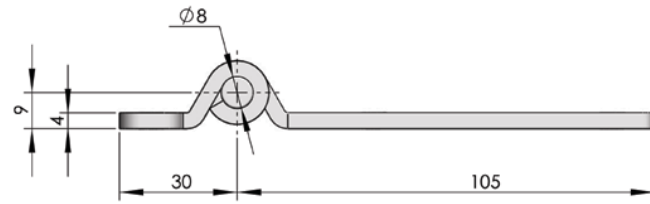

CL127-1

ERP CL127S4A002

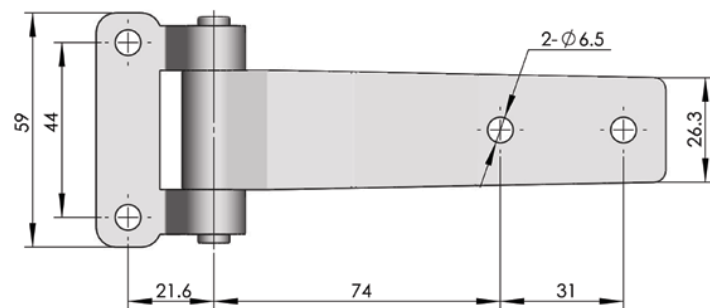
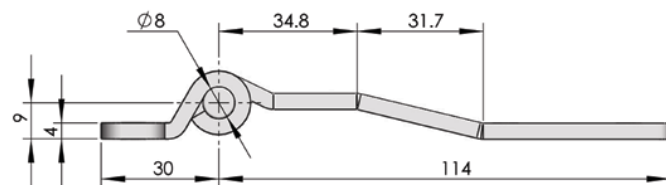

CL127-2

ERP CL127S4A003

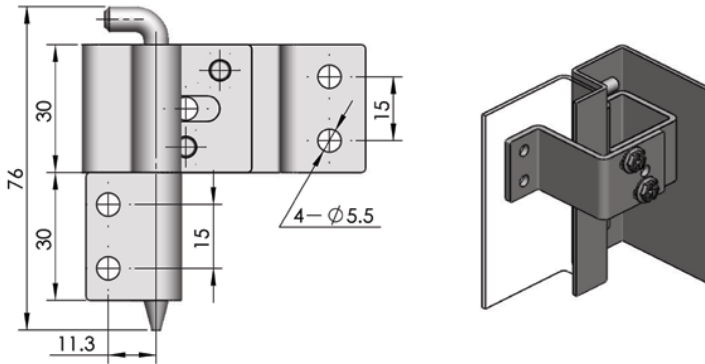
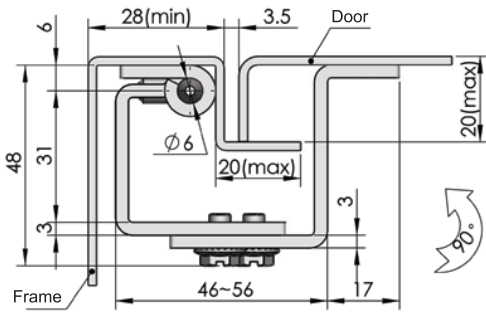

ERP CL128F3D001

CL128



Main material and finish: 3+ zinc plated steel hinge and pin
 Application: Opening angle 90°

Performance parameter:
 Maximum static load
 Radial load: 160N
 Axial load: 140N

Accessories

Electronic lock

Handle lock

Cylinder lock

Plane lock

Rod control lock

Panel lock

Toggle and hook

Handles

Door stop

Hinge

Seal gasket

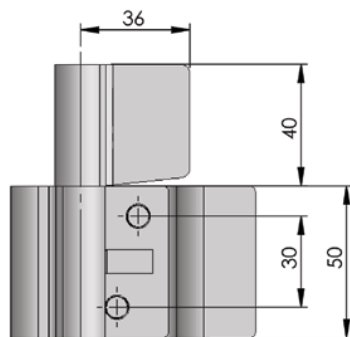
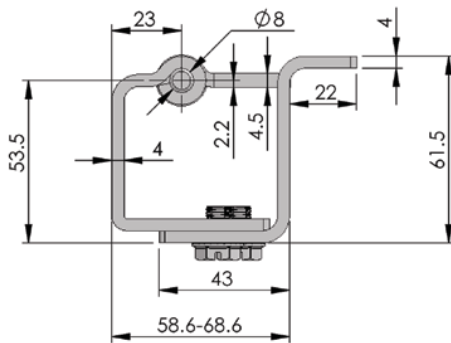



ERP CL128F3D004

CL128-2





Main material and finish: 3+ zinc plated steel hinge and pin

Performance parameter:
 Maximum static load
 Radial load: 375N
 Axial load: 305N

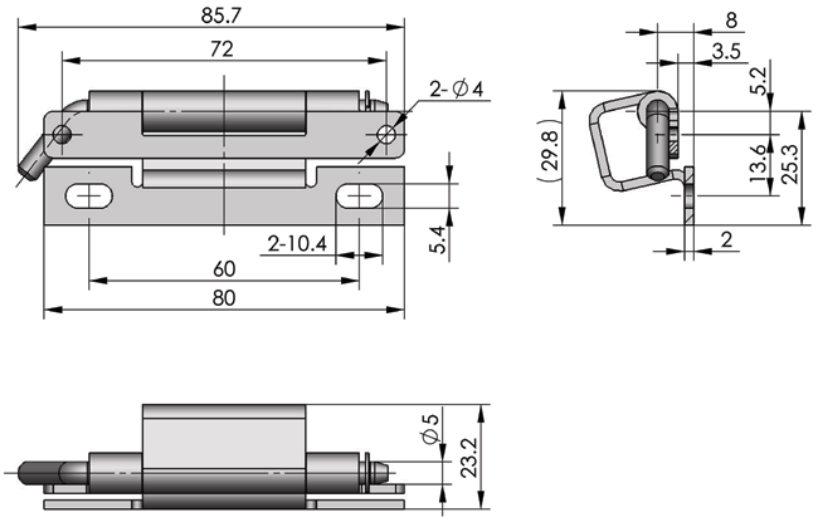
Accessories	 <p>CL129</p>  <p>Main material: steel Finish: zinc plated</p> <p>Performance parameter: Maximum static load Radial load: 180N Axial load: 250N</p>
Electronic lock	
Handle lock	
Cylinder lock	
Plane lock	
Rod control lock	



ERP CL129F3D001

Panel lock	 <p>CL130-2</p>  <p>Main material and finish: 3+ zinc plated steel hinge and pin Application: When the gap between door and frame is 2mm, opening angle 90°</p> <p>Performance parameter: Maximum static load Radial load: 1125N Axial load: 1320N</p>
Toggle and hook	
Handles	
Door stop	
Hinge	
Seal gasket	

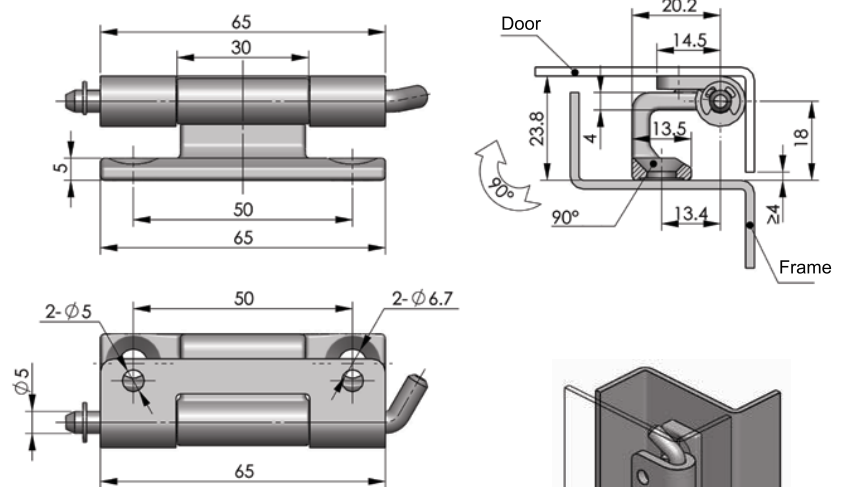

ERP CL130F3D001

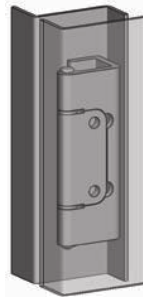
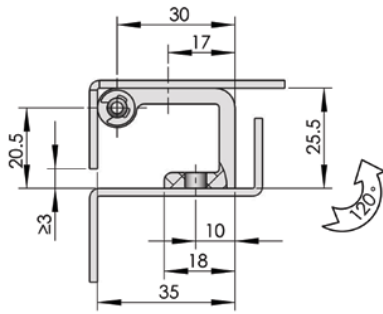
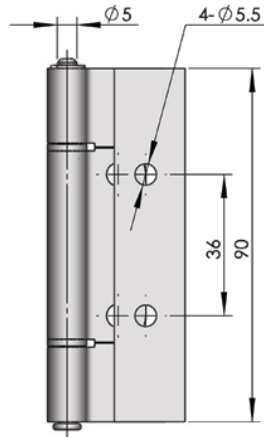

ERP CL132A4D001

CL132



Main material and finish: Sand-spraying aluminum alloy hinge, stainless steel pin
Application: Opening angle 120°

Performance parameter:
Maximum static load
Radial load: 800N
Axial load: 425N

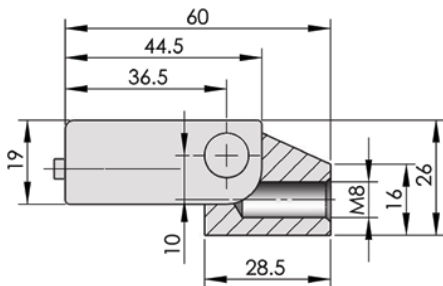
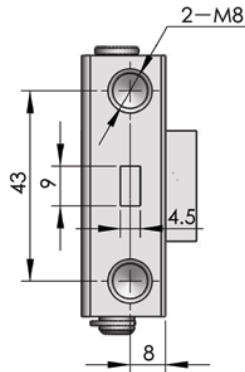
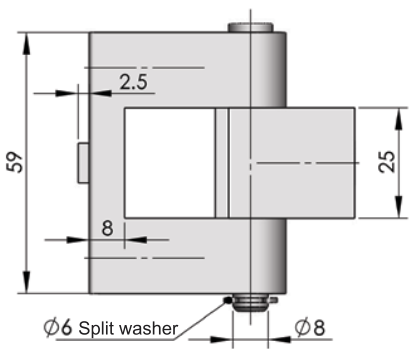

ERP CL133F3D001



CL133



Main material and finish: White zinc-plated steel hinge leaf and shaft
Application: Opening angle 180°



Performance parameter:
Maximum static load
Radial load: 1450N
Axial load: 2000N

- Accessories
- Electronic lock
- Handle lock
- Cylinder lock
- Plane lock
- Rod control lock
- Panel lock
- Toggle and hook
- Handles
- Door stop
- Hinge
- Seal gasket

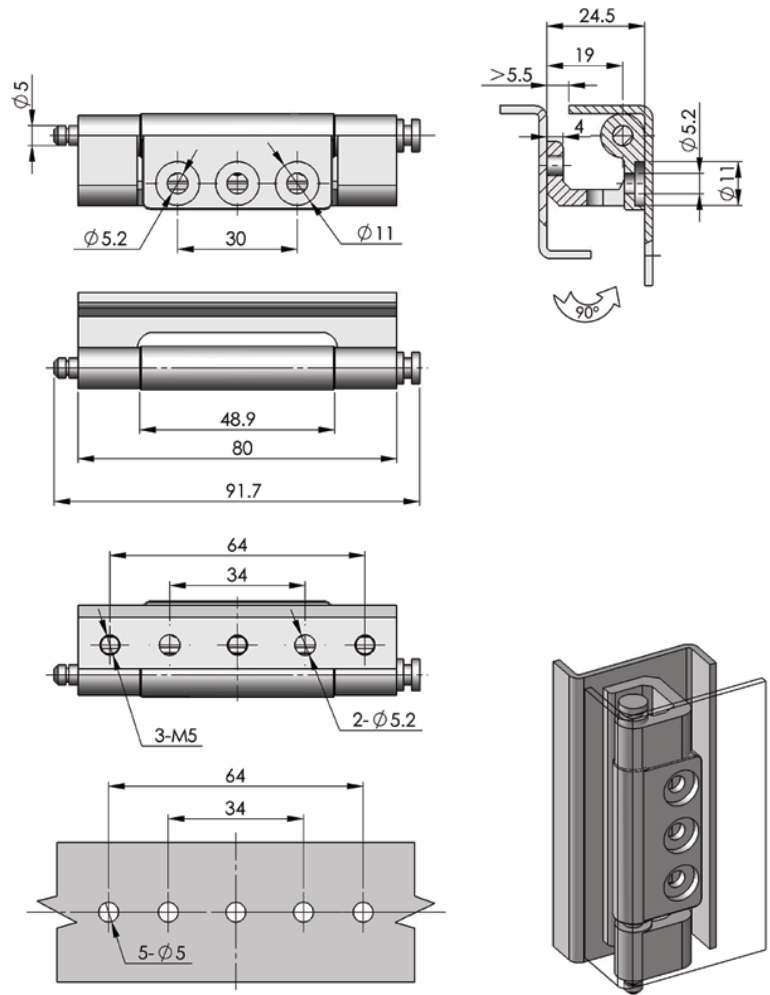
Accessories	<p>CL132-2</p> 
Electronic lock	
Handle lock	
Cylinder lock	
Plane lock	
Rod control lock	 <p>Main material and finish: Electrolytic stainless steel hinge Application: Opening angle 90°</p> <p>Performance parameter: Maximum static load Radial load: 465N Axial load: 650N</p>
Panel lock	
Rod control lock	
Panel lock	



ERP CL132S9C001

Toggle and hook	<p>CL133-2</p> 
Handles	
Door stop	
Hinge	
Seal gasket	
	 <p>Main material and finish: Color zinc-plated ZDC hinge and pin Application: Opening angle 115°</p> <p>Performance parameter: Maximum static load Radial load: 1000N Axial load: 720N</p>

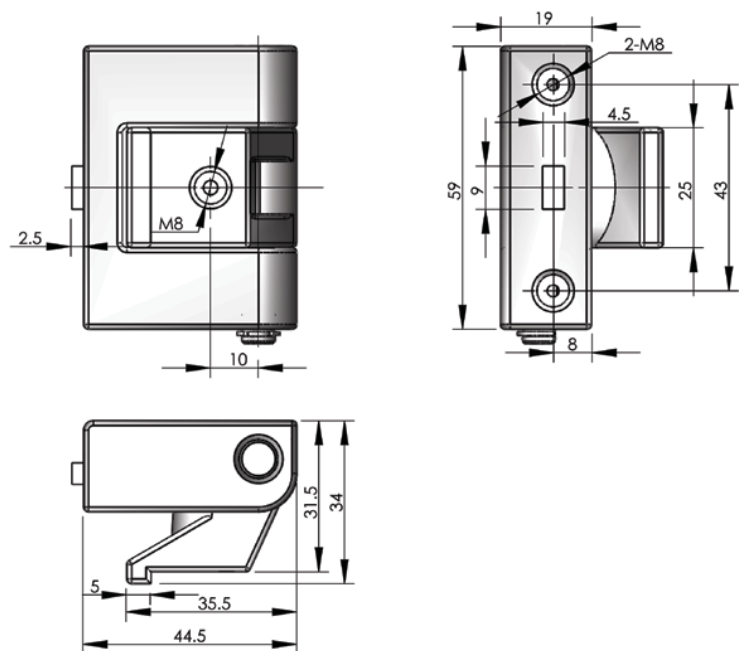

ERP CL133Z3C001

CL135-1

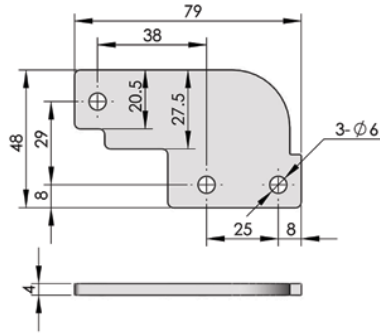

ERP CL135F2A001

CL135-2

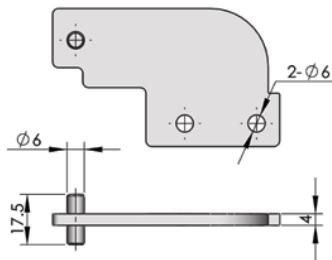

ERP CL135F2A002

CL135-3

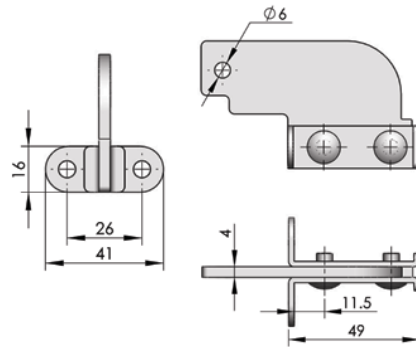

ERP CL135F2A003

CL135-4

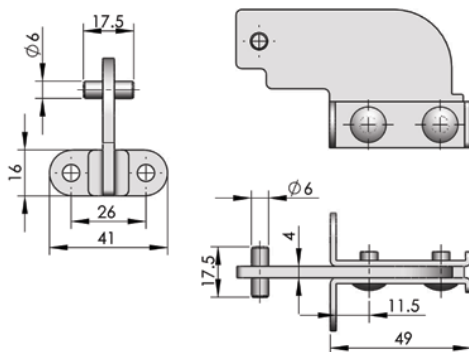

ERP CL135F2A004

CL135



Main material and finish: Black painted steel hinge

Accessories
Electronic lock
Handle lock
Cylinder lock
Plane lock
Rod control lock
Panel lock
Toggle and hook
Handles
Door stop
Hinge
Seal gasket

Accessories

Electronic lock

Handle lock

Cylinder lock

Plane lock

Rod control lock

CL137



Main material and finish: White zinc-plated steel hinge and pin
Application: Opening angle 135°

Performance parameter:
Maximum static load
Radial load: 520N
Axial load: 375N

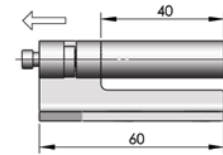
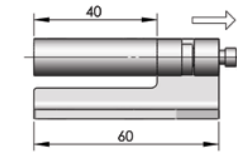
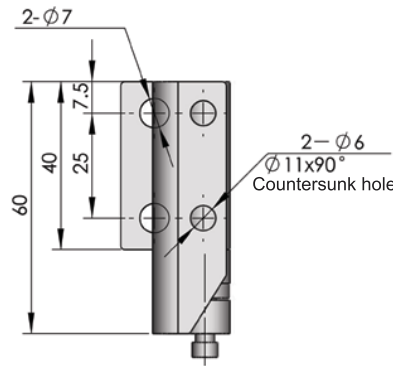

CL137 Right

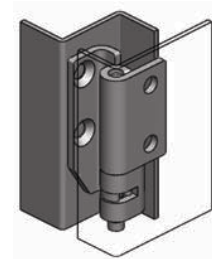
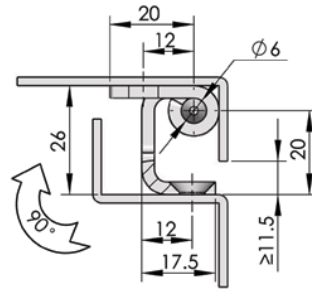

	CL137-Z Left hinge	CL137-Y Right hinge
ERP	CL137F3D001	CL137F3D002

Panel lock

Toggle and hook

Handles

Door stop

Hinge

Seal gasket

CL138



Main material and finish: 3+ zinc plated steel hinge and pin
Application: Opening angle 135°

Performance parameter:
Maximum static load
Radial load: 690N
Axial load: 630N

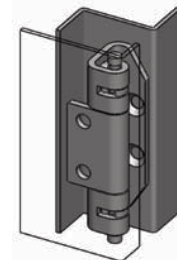
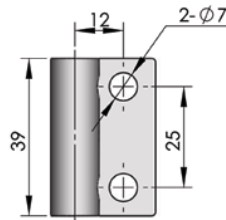
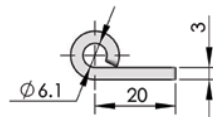
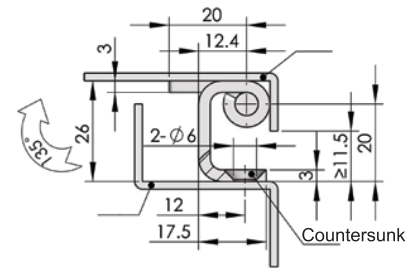
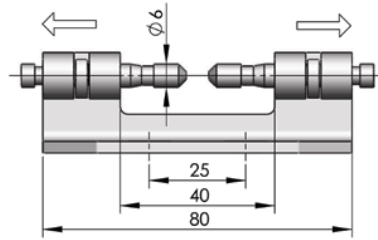

ERP	CL138F3D001
-----	-------------

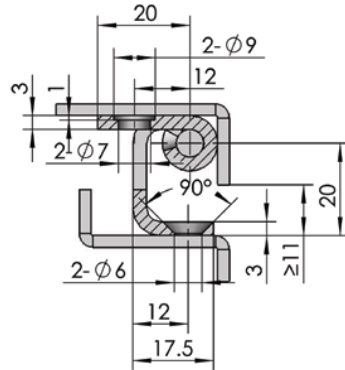
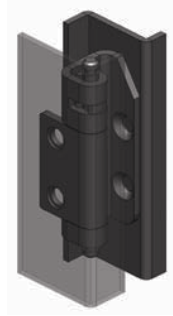
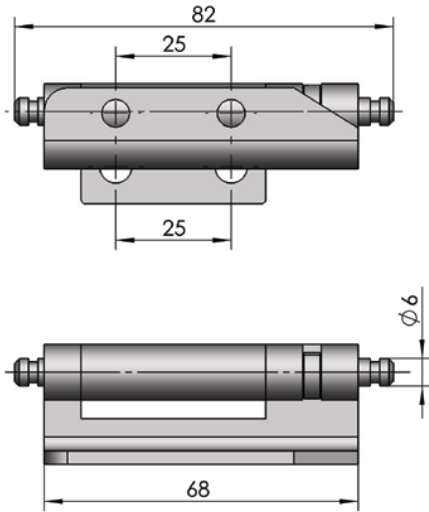

	CL138-3-Z	CL138-3-Y
ERP	CL138F3D004	CL138F3D005

CL138-3



Main material and finish: Trivalent 3+ zinc plated steel hinge and pin
Application: Opening angle 90°

Performance parameter:
Maximum static load
Radial load: 385N
Axial load: 600N

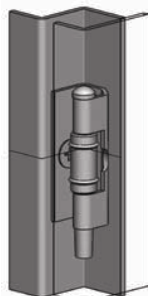
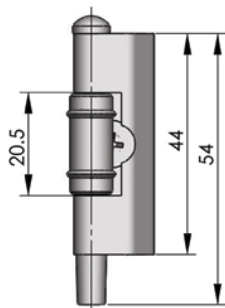
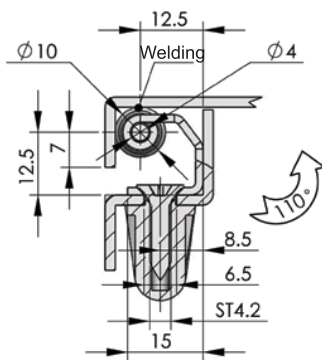

ERP	CL139F3D001
-----	-------------

CL139



Main material and finish: 3+ zinc plated steel hinge and pin
Application: Opening angle 135°

Performance parameter:
Maximum static load
Radial load: 215N
Axial load: 195N

Accessories

Electronic lock

Handle lock

Cylinder lock

Plane lock

Rod control lock

Panel lock

Toggle and hook

Handles

Door stop

Hinge

Seal gasket

Accessories

Electronic lock

Handle lock

Cylinder lock

Plane lock

Rod control lock

Panel lock

Toggle and hook

Handles

Door stop

Hinge

Seal gasket



CL142



INOX
AISI 316

Main material and finish: Mirror polishing stainless steel hinge
Application: Opening angle 135°

Performance parameter:
Maximum static load
Radial load: 2170N
Axial load: 3000N

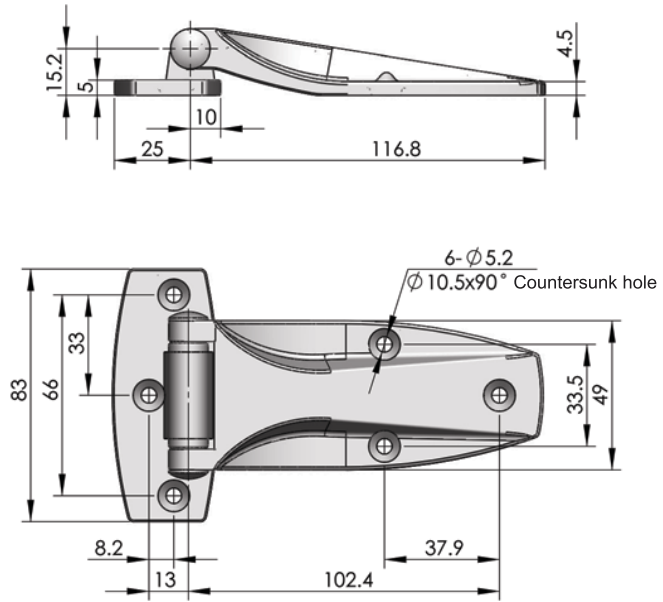

ERP CL142S4A001



CL145



Main material and finish: White zinc-plated steel hinge leaf and shaft

Performance parameter:
Maximum static load
Radial load: 193N
Axial load: 455N

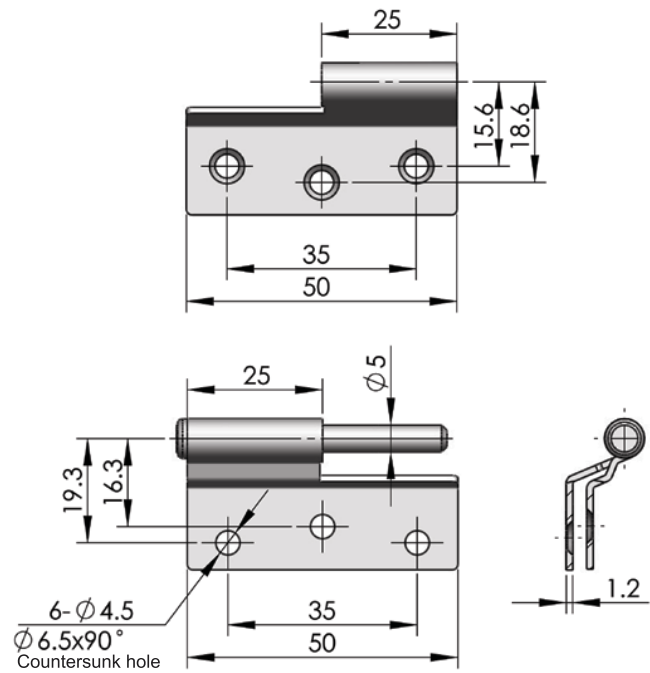

ERP CL145F3D001

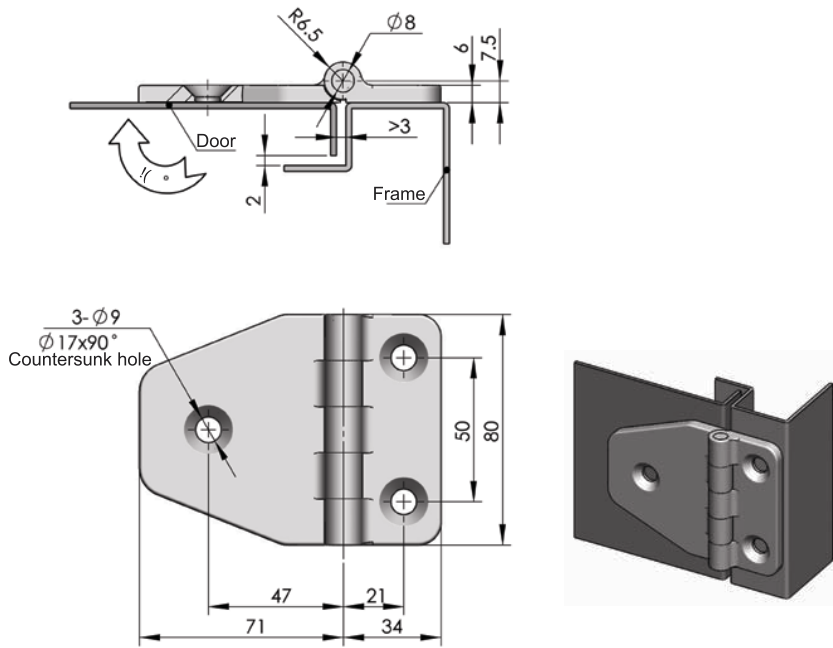

ERP

CL148N00001

CL148



Main material and finish: White zinc-plated steel shaft, PA (black) hinge leaf
Application: Opening angle 180°

Performance parameter:

Maximum static load

Radial load: 220N

Axial load: 450N

Accessories

Electronic lock

Handle lock

Cylinder lock

Plane lock

Rod control lock

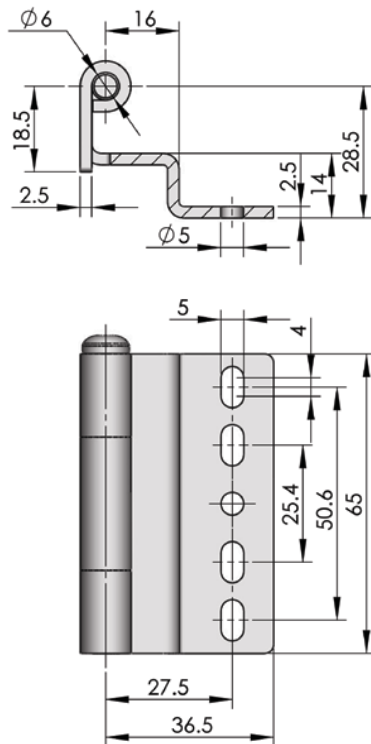

ERP

CL150F3D001

CL150



Main material and finish: 3+ zinc plated steel hinge and shaft

Performance parameter:

Maximum static load

Radial load: 495N

Axial load: 545N

Panel lock



Toggle and hook

Handles

Door stop



Hinge

Seal gasket

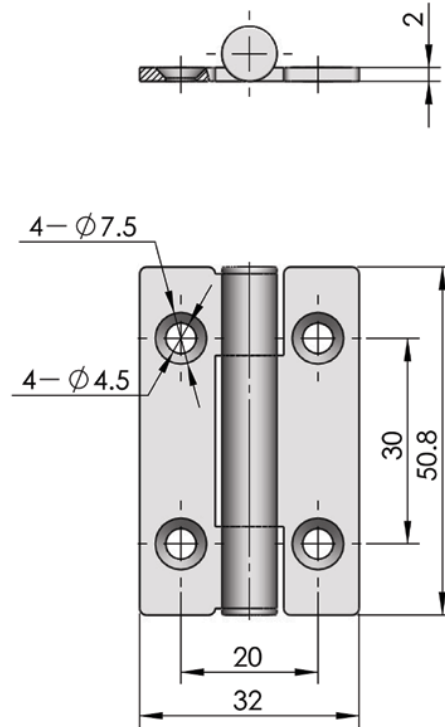
Accessories	 <p>CL152</p>  <p>Main material and finish: Electrolytic stainless steel hinge and pin Application: Opening angle 180°</p> <p>Performance parameter: Maximum static load Radial load: 620N Axial load: 1170N</p>
Electronic lock	
Handle lock	
Cylinder lock	
Plane lock	
Rod control lock	



ERP CL152S9C001

Panel lock	 <p>CL152-2</p>  <p>Main material and finish: Electrolytic stainless steel hinge and shaft Application: Opening angle 180°</p> <p>Performance parameter: Maximum static load Radial load: 620N Axial load: 1170N</p>
Toggle and hook	
Handles	
Door stop	
Hinge	
Seal gasket	

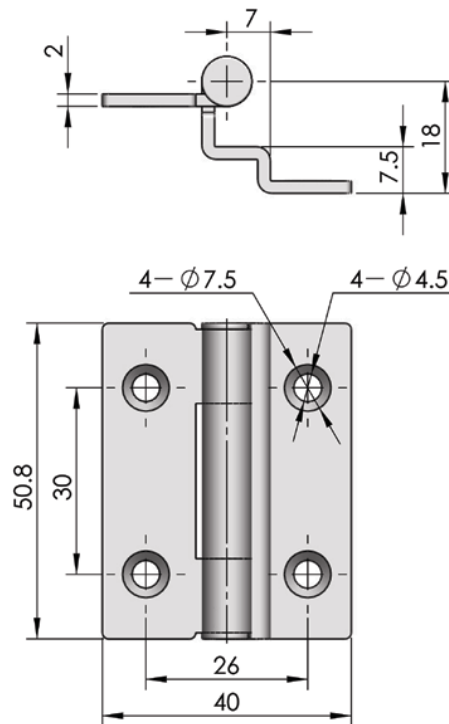

ERP CL152S9C002

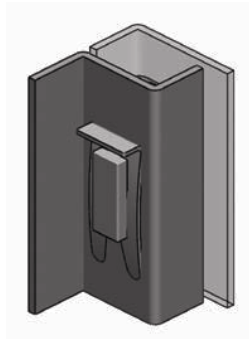
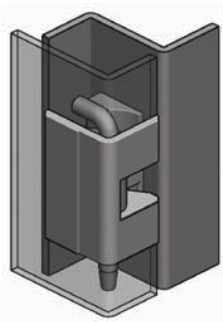
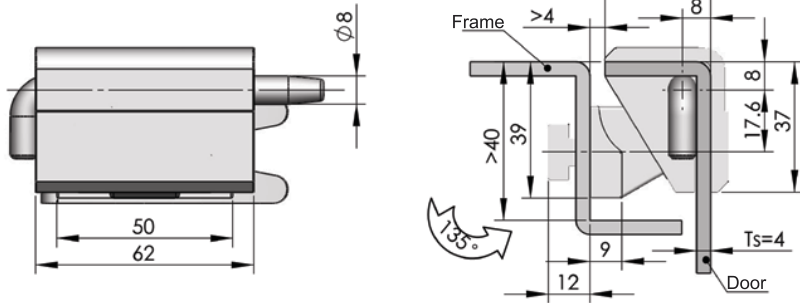

CL154



Main material and finish: Blue-gray (RAL 7012) powder coated ZDC hinge and stainless steel shaft
Application: Opening angle 135°

Performance parameter:

Maximum static load

Radial load: 2500N

Axial load: 2200N

Accessories

Electronic lock

Handle lock

Cylinder lock

Plane lock

Rod control lock

Panel lock

Toggle and hook

Handles

Door stop

Hinge

Seal gasket

Frame cutout

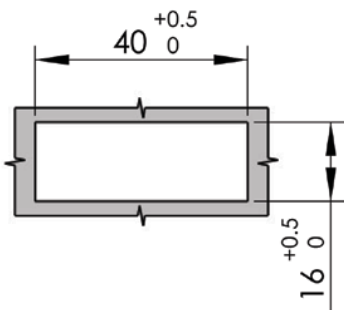

Door cutout

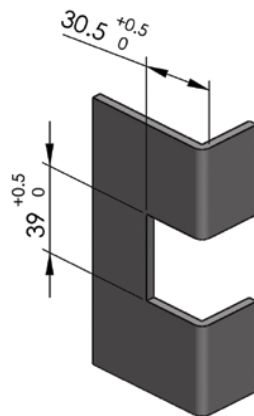



ERP

CL154ZXX001

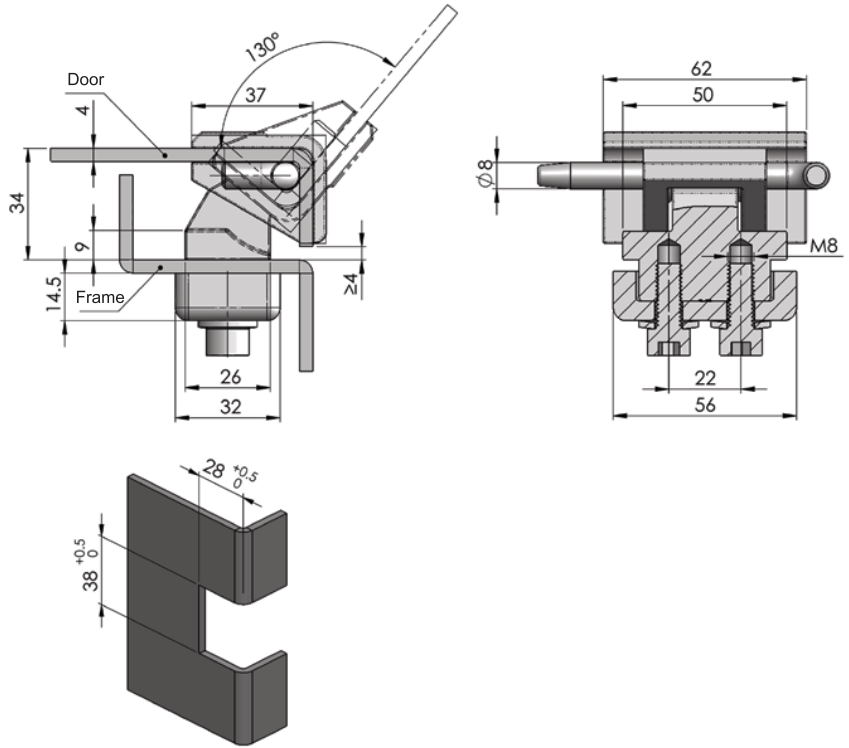
Accessories	 <p>CL154-3</p> <p>NEW</p>
Electronic lock	
Handle lock	
Cylinder lock	
Plane lock	
Rod control lock	 <p>Main material: ZDC hinge, stainless steel pin, steel board Finish: RAL7012 powder coated Application: Opening angle 130°</p> <p>Performance parameter: Maximum static load Radial load: 2000N Axial load: 2000N</p>



ERP CL154Z1D002

Panel lock	 <p>CL156</p>
Toggle and hook	
Handles	
Door stop	
Hinge	
Seal gasket	 <p>Main material and finish: Sand-spraying aluminum alloy hinge, stainless steel shaft Application: Opening angle 180°</p> <p>Performance parameter: Maximum static load Radial load: 620N Axial load: 365N</p>

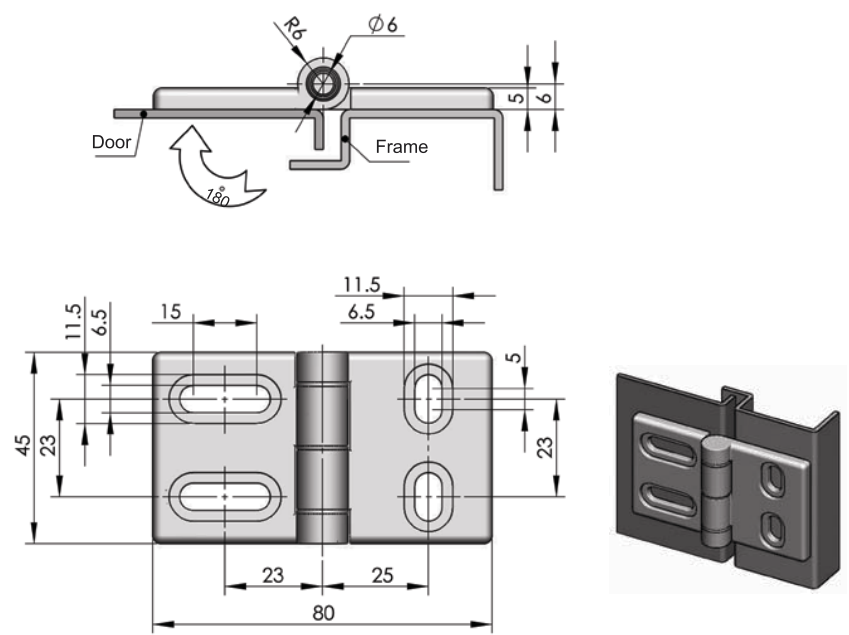

ERP CL156A4D001

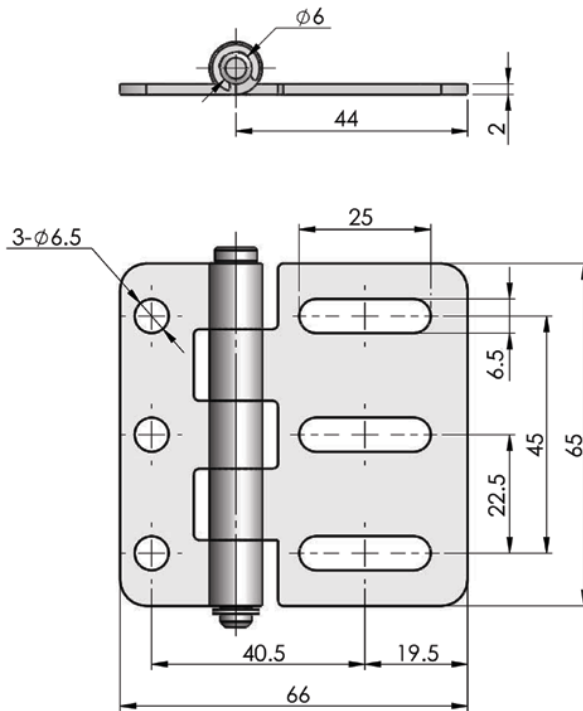

ERP

CL156S4A001

CL156-2



Main material: stainless steel 304
Finish: mirror polishing
Application: Opening angle 90°
Type: exposed hinge

Performance parameter:
Maximum static load
Radial load: 350N
Axial load: 450N

Accessories

Electronic lock

Handle lock

Cylinder lock

Plane lock

Rod control lock

Panel lock

Toggle and hook

Handles

Door stop

Hinge

Seal gasket

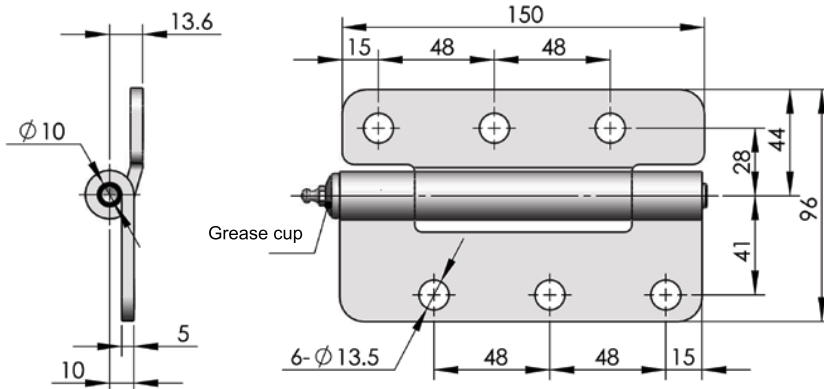

ERP

CL158F3D001

CL158



Main material and finish: White zinc-plated steel hinge leaf and shaft

Performance parameter:
Maximum static load
Radial load: 3000N
Axial load: 2500N

- Accessories
- Electronic lock
- Handle lock
- Cylinder lock
- Plane lock
- Rod control lock
- Panel lock
- Toggle and hook
- Handles
- Door stop
- Hinge
- Seal gasket

CL158-2



Main material and finish: Wiredrawing stainless steel hinge leaf, stainless steel shaft
 Application: Opening angle 180°

Performance parameter:
 Maximum static load
 Radial load: 1500N
 Axial load: 1200N

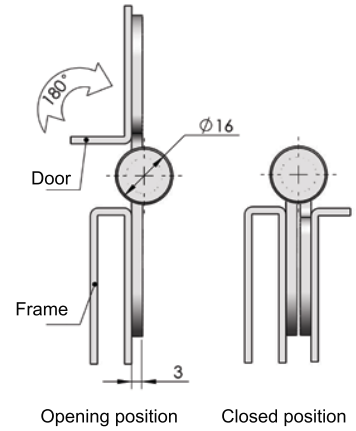
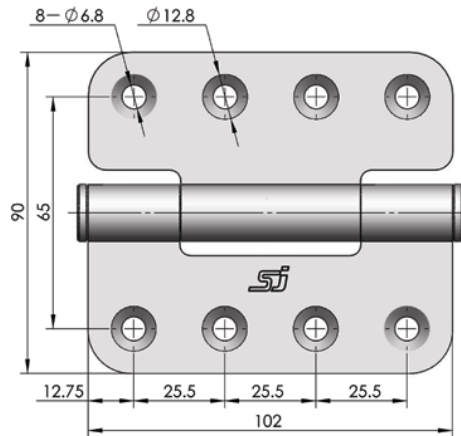

ERP CL158S4B001

CL158-3



Main material and finish: stainless steel (brushed polishing) hinge, steel pin
 Application: Opening angle 180°

Performance parameter:
 Maximum static load
 Radial load: 1730N
 Axial load: 2000N

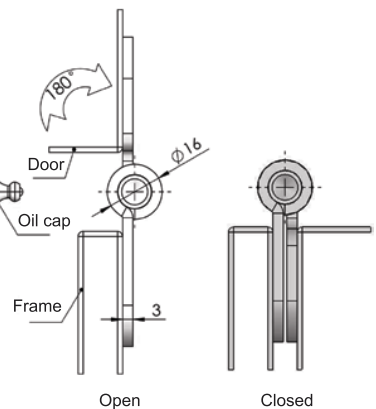
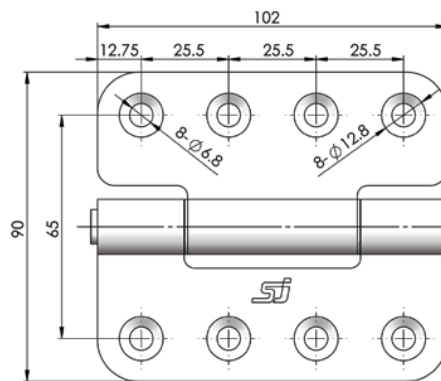

ERP CL158S4B002

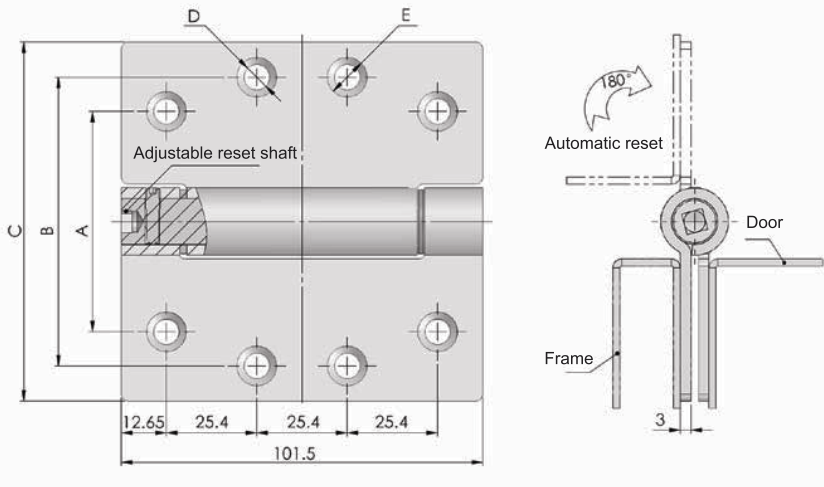

Model	ERP	specification				
		A	B	C	D	E
CL158-4	CL158S4B003	62	81.2	101	7.2	10.5
CL158-5	CL158S4B004	37	56.2	76	6.6	10

CL158-4



CL158-5



Main material: stainless steel hinge and pin
 Finish: brushed polishing
 Application: reset hinge, opening angle 180°
 Performance parameter:
 Reset torque 2N.m

Accessories

Electronic lock

Handle lock

Cylinder lock

Plane lock

Rod control lock

Panel lock

Toggle and hook

Handles

Door stop

Hinge

Seal gasket

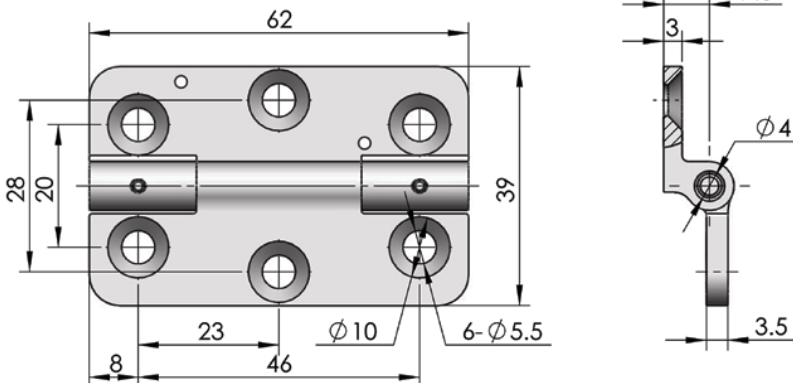

CL163



Main material and finish: Wiredrawing stainless steel hinge leaf and shaft

Performance parameter:
 Maximum static load
 Radial load: 1300N
 Axial load: 1180N



ERP CL163S4B001

Accessories	<p>CL167</p> 
Electronic lock	
Handle lock	
Cylinder lock	
Plane lock	
Rod control lock	<p>Main material and finish: White zinc-plated steel hinge leaf, white zinc-plated aluminium alloy shaft</p> <p>Application: Opening angle 120°</p> <p>Performance parameter: Maximum static load Radial load: 210N Axial load: 320N</p>

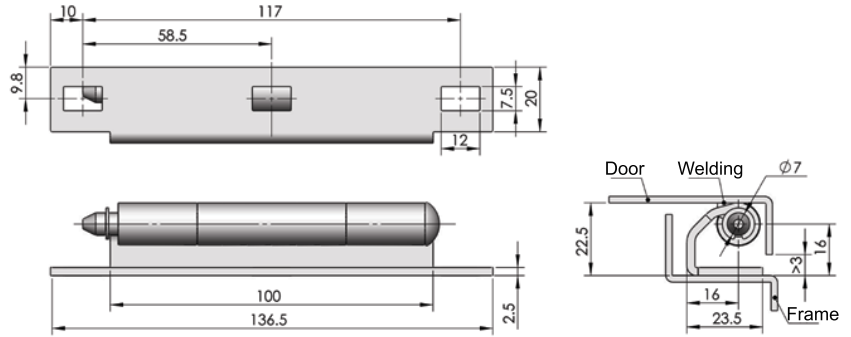

ERP CL167F3D001

Panel lock	<p>CL168</p> 
Toggle and hook	
Handles	
Door stop	
Hinge	
Seal gasket	<p>Main material and finish: White zinc-plated steel hinge leaf and shaft</p> <p>Performance parameter: Maximum static load Radial load: 200N Axial load: 330N</p>

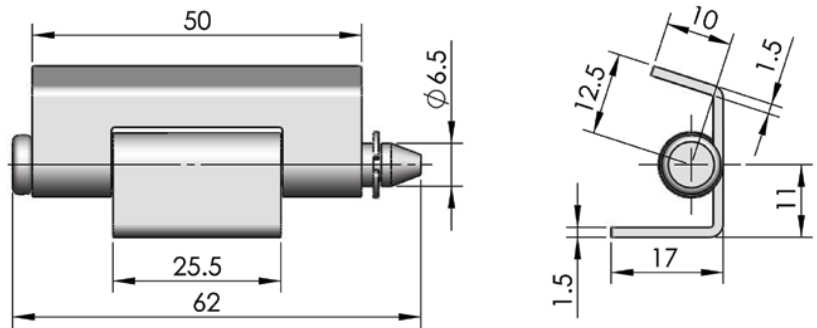

ERP CL168F3D001

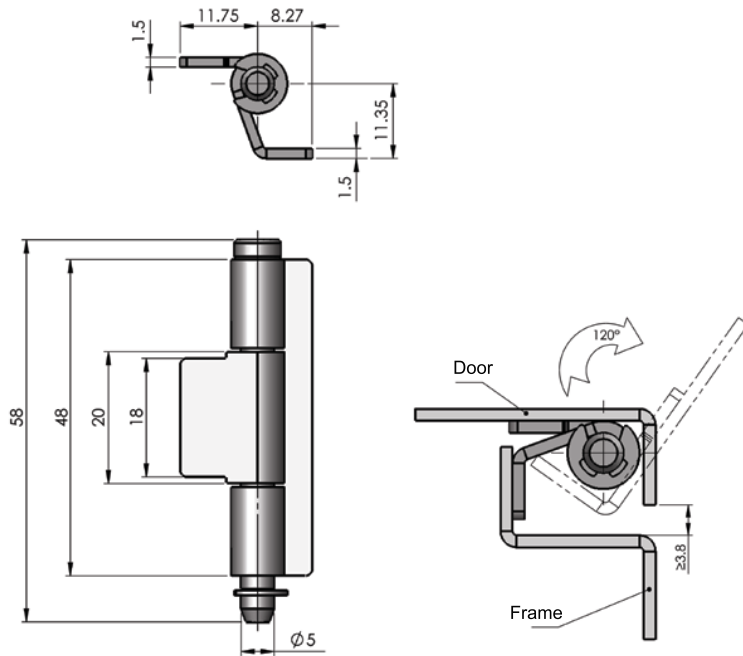

ERP CL168S4A001

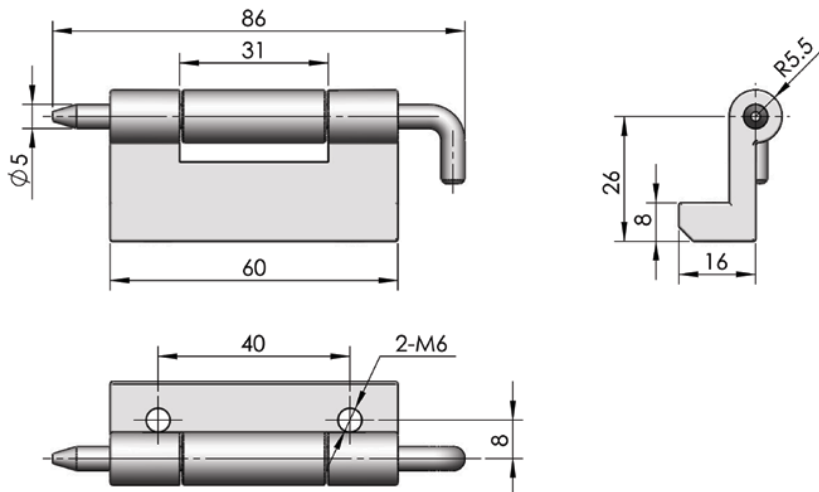

ERP CL169Z3D001

CL168-2



Main material: stainless steel 304
Finish: mirror polishing
Application: Opening angle 120°

Performance parameter:
Maximum static load
Radial load: 290N
Axial load: 540N

Accessories

Electronic lock

Handle lock

Cylinder lock

Plane lock

Rod control lock

Panel lock

Toggle and hook

Handles

Door stop

Hinge



Seal gasket

CL169





Main material and finish: White zinc-plated ZDC female hinge, steel male hinge and shaft

Performance parameter:
Maximum static load
Radial load: 700N
Axial load: 500N

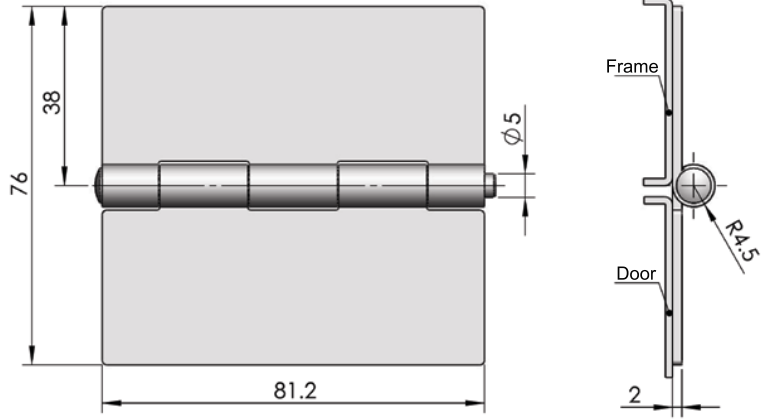
Accessories	<p>CL170</p>   <p>Main material and finish: Zinc-plated steel hinge and pin</p> <p>Performance parameter: Maximum static load Radial load: 800N Axial load: 600N</p>
Electronic lock	
Handle lock	
Cylinder lock	
Plane lock	
Rod control lock	
Panel lock	
Toggle and hook	
Handles	
Door stop	



ERP CL170F3D001

Panel lock	<p>CL173</p>   <p>Main material and finish: Stainless steel hinge leaf and shaft</p> <p>Application: Opening angle 90°</p> <p>Performance parameter: Maximum static load Radial load: 180N Axial load: 75N</p>
Toggle and hook	
Handles	
Door stop	
Hinge	
Seal gasket	

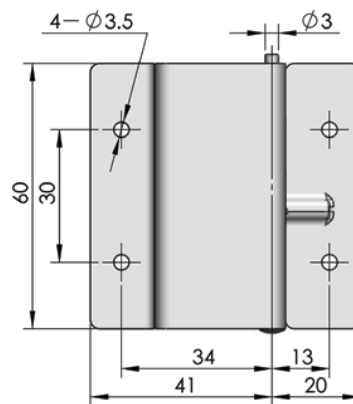
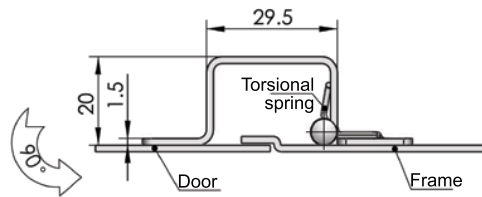

ERP CL173S00001

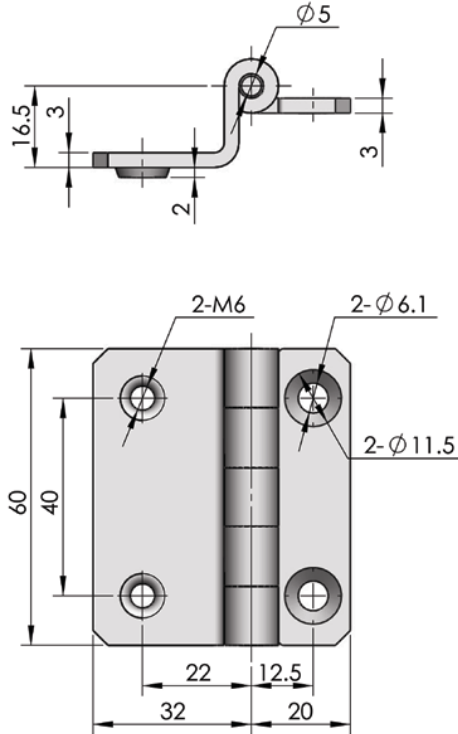

ERP CL178F3D001

CL178



Main material: steel hinge and pin
Finish: zinc plated

Performance parameter:
Maximum static load
Radial load: 1280N
Axial load: 1170N

Accessories

Electronic lock

Handle lock

Cylinder lock

Plane lock

Rod control lock

Panel lock

Toggle and hook

Handles

Door stop

Hinge

Seal gasket

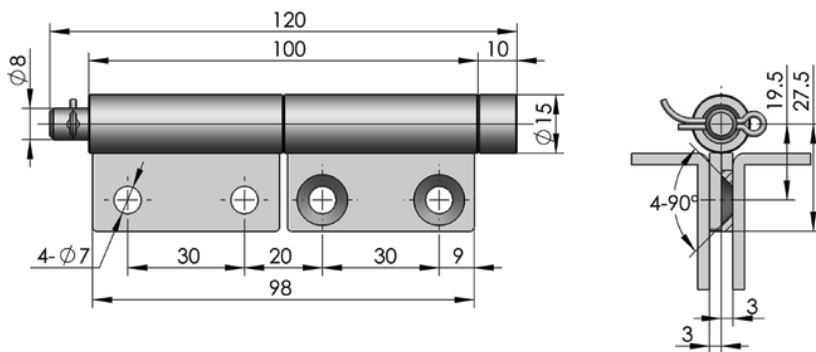

ERP CL179S4B001

CL179



Main material and finish: Wiredrawing stainless steel hinge

Performance parameter:
Maximum static load
Radial load: 2000N
Axial load: 1500N

- Accessories
- Electronic lock
- Handle lock
- Cylinder lock
- Plane lock
- Rod control lock
- Panel lock
- Toggle and hook
- Handles
- Door stop
- Hinge
- Seal gasket

CL180



Main material and finish: Magnetic force polishing SUS304 stainless steel hinge

Performance parameter:
Maximum static load
Radial load: 705N
Axial load: 400N

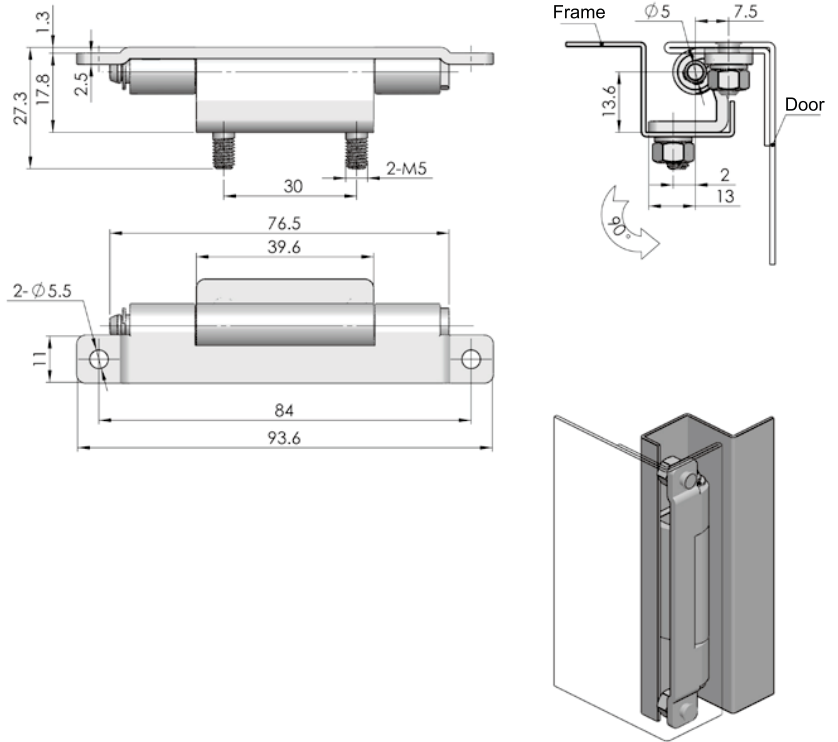

ERP

CL180SXX001

CL181



Main material and finish: White zinc plated steel hinge leaf and stainless steel shaft

Performance parameter:
Maximum static load
Radial load: 5000N
Axial load: 420N

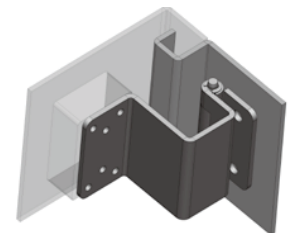
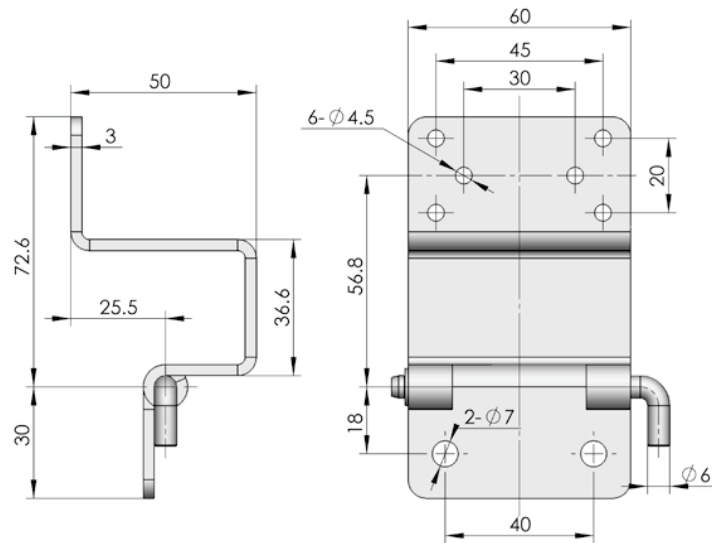

ERP

CL181F3J001

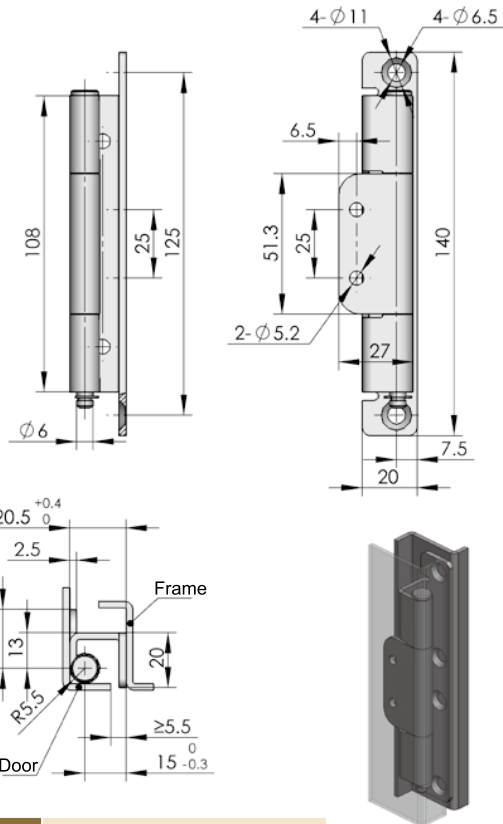

ERP

CL186S9C001

CL186



Main material and finish: Electrolysis stainless steel hinge leaf and shaft
Application: Opening angle 120°

Performance parameter:
Maximum static load
Radial load: 660N
Axial load: 800N

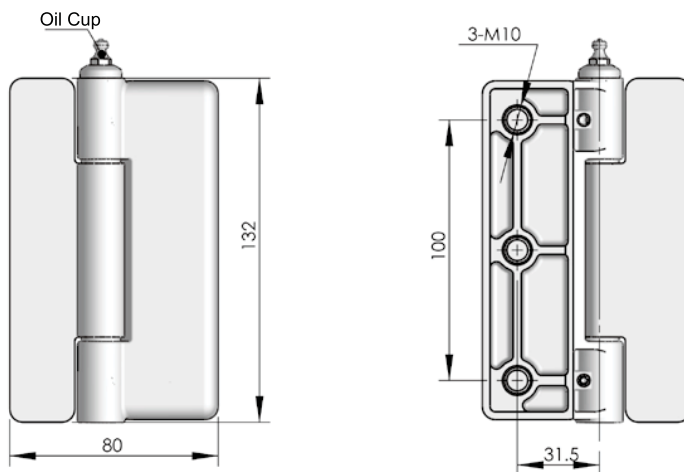
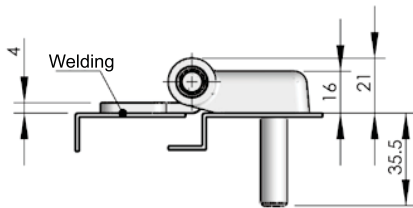

ERP

CL188FXX001

CL188



Main material and finish: Phosphating 45# steel hinge
Application: Opening angle 180°

Performance parameter:
Maximum static load
Radial load: 3000N
Axial load: 3000N

Accessories

Electronic lock

Handle lock

Cylinder lock

Plane lock

Rod control lock

Panel lock

Toggle and hook

Handles

Door stop

Hinge

Seal gasket

- Accessories
- Electronic lock
- Handle lock
- Cylinder lock
- Plane lock
- Rod control lock
- Panel lock
- Toggle and hook
- Handles
- Door stop
- Hinge
- Seal gasket

CL190



Main material and finish: White zinc plated steel hinge

Performance parameter:
 Maximum static load
 Radial load: 365N
 Axial load: 255N

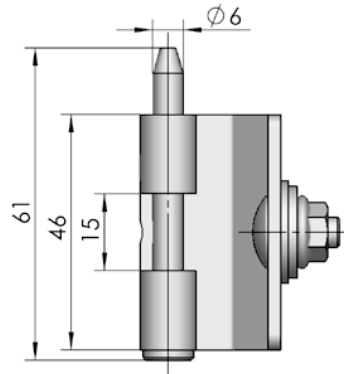
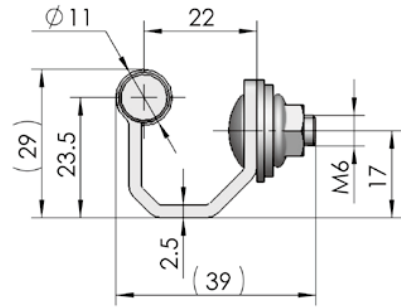

ERP CL190F3D001

CL195



Main material and finish: Black POM hinge and steel shaft
 Application: Opening angle 150°

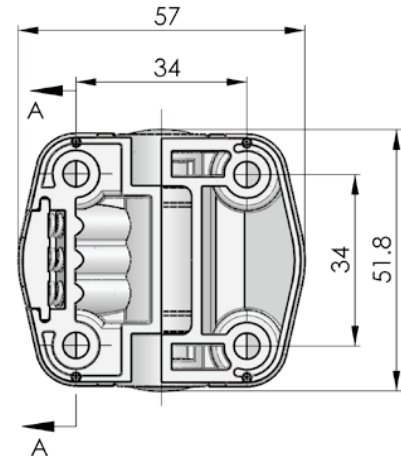
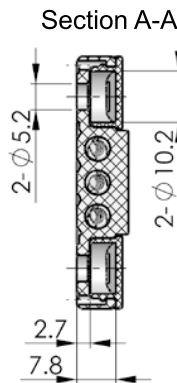
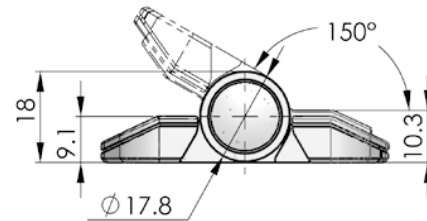

ERP CL195N00001

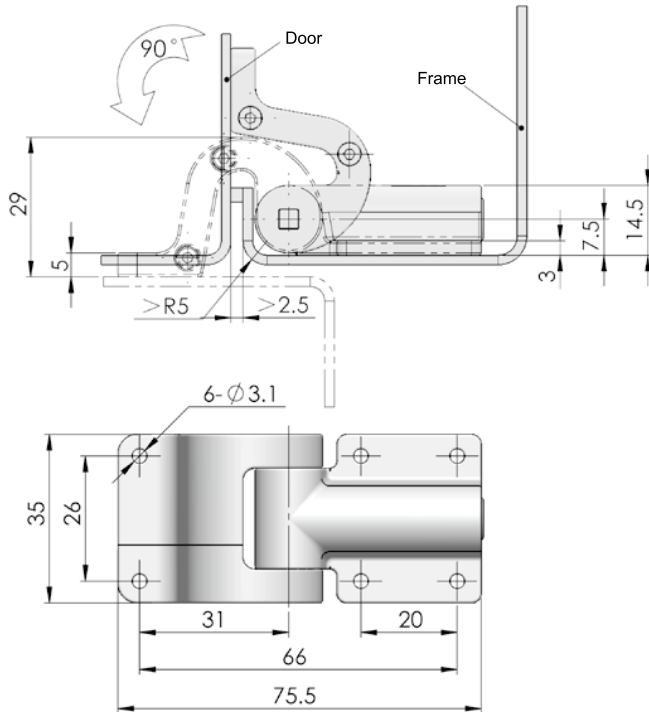

ERP CL195Z2A002

CL195-3



Main material and finish: Black painted ZDC hinge
Application: Opening angle 90°

Performance parameter:
Maximum static load
Radial load: 800N
Axial load: 650N

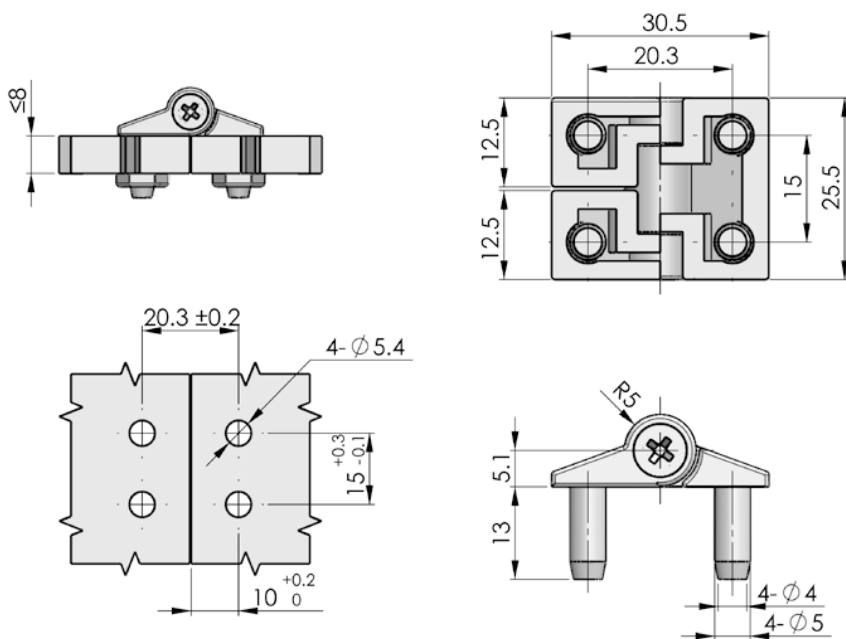

ERP CL196N00001

CL196



Main material and finish: Black POM hinge
Remark: Special self tapping screw included

Performance parameter:
Maximum static load
Radial load: 80N
Axial load: 255N

Accessories

Electronic lock

Handle lock

Cylinder lock

Plane lock

Rod control lock

Panel lock

Toggle and hook

Handles

Door stop

Hinge

Seal gasket



- Accessories
- Electronic lock
- Handle lock
- Cylinder lock
- Plane lock
- Rod control lock
- Panel lock
- Toggle and hook
- Handles
- Door stop
- Hinge
- Seal gasket

CL201-1



CL201-1A

Main material and finish: ZDC hinge, steel pin, accessory

Performance parameter:
 Maximum static load
 Radial load: 800N
 Axial load: 1500N

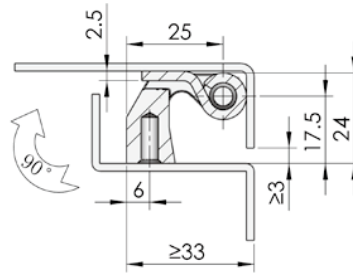
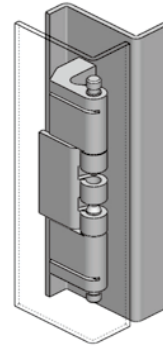
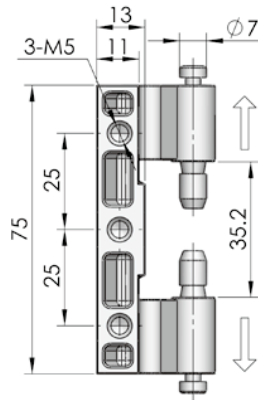

CL201-1

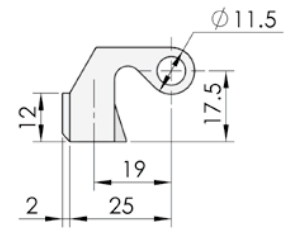

CL201-1A

Remark: £size is 3.7, door's open angle is 90 degree.

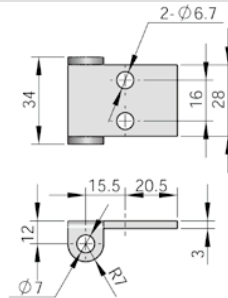

"U" shape accessory

ERP: 3452011001 (white zinc plating)

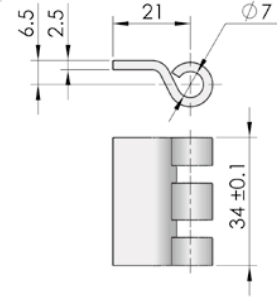

Claw shape accessory

ERP: 3452011002 (white zinc plating)

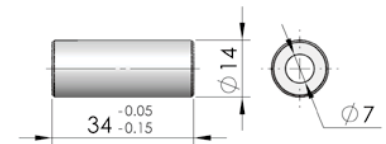

Pipe shape accessory

ERP: 3452011013 (white zinc plating)

Specification	CL201-1	CL201-1A	CL201-1B
Black powder coated	CL201Z2A002	CL201Z2A032	
Nanometer painted	CL201Z2B002	CL201Z2B017	
Blast sprayed	CL201Z4D002	CL201Z4D004	
SUS			CL201S4B001

Remark: Accessory is not included in above ERP number, but optional

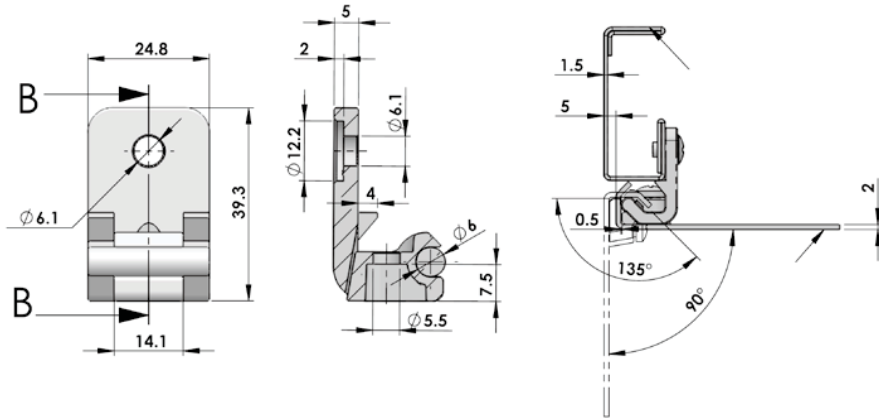

ERP

CL200Z2C001

CL200-1



NEW



Main material and finish: Black painted ZDC hinge
Application: Opening angle 90°

Performance parameter:
Maximum static load
Radial load: 300N
Axial load: 250N

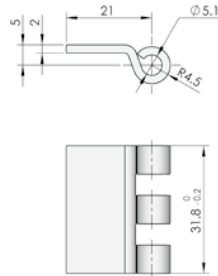
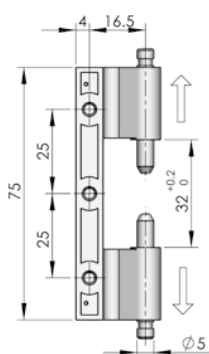
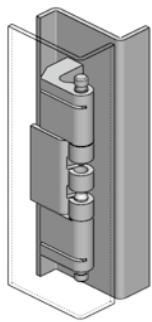

Claw shape accessory

ERP: 3452012001
(Iron white zinc plating)

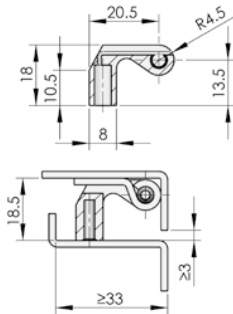

Remark: £3 size is bigger, door's open angle is bigger
What is the size of the door panel and door frame, when the door's open angle is 90 degree.

CL201-2



Main material and finish: ZDC hinge, steel pin and accessories

Performance parameter:
Maximum static load
Radial load: 360N
Axial load: 460N

	Black powder coated	Nanometer painted	Blast sprayed
ERP	CL201Z2A006	CL201Z2B004	CL201Z4D007

Remark: Accessory is not included in above ERP number, but optional.

Accessories

Electronic lock

Handle lock

Cylinder lock

Plane lock

Rod control lock

Panel lock

Toggle and hook

Handles

Door stop

Hinge

Seal gasket

- Accessories
- Electronic lock
- Handle lock
- Cylinder lock
- Plane lock
- Rod control lock
- Panel lock
- Toggle and hook
- Handles
- Door stop
- Hinge
- Seal gasket

CL201-3



Main material and finish: ZDC hinge, steel pin and accessories

Performance parameter:
 Maximum static load
 Radial load: 300N
 Axial load: 700N

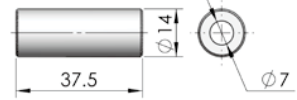
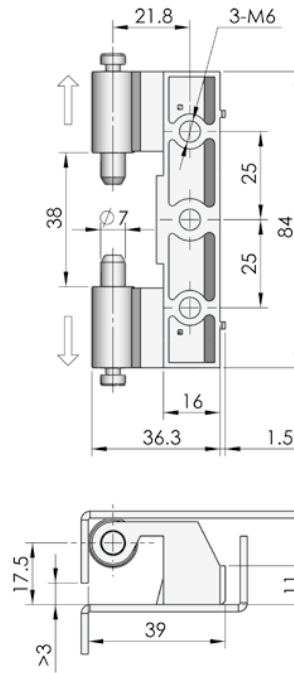

Pipe shape accessory
 ERP: 3452013002
 (White zinc plating)

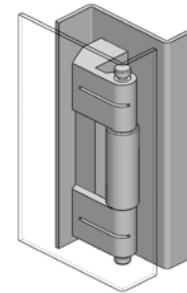

Remark: £size is 3.7, door's open angle is 90 degree.

	Black powder coated	Nanometer painted	Blast sprayed
ERP	CL201Z2A011	CL201Z2B008	CL201Z4D009

Remark: Accessory is not included in above ERP number, but optional.

CL201-4



Main material and finish: ZDC hinge, steel pin and accessories

Performance parameter:
 Maximum static load
 Radial load: 640N
 Axial load: 900N

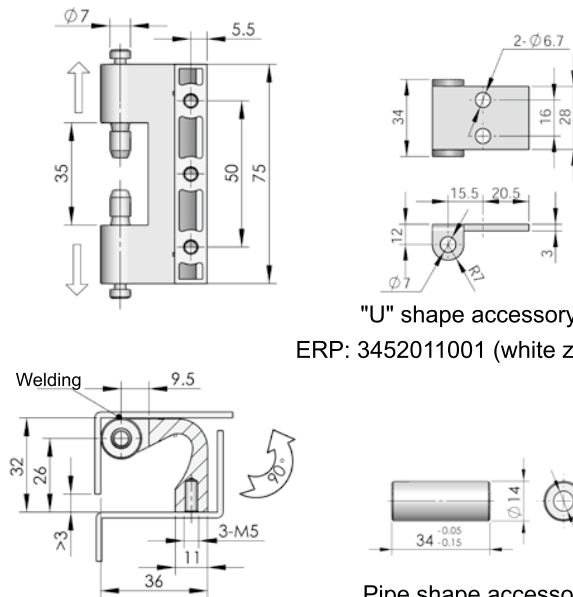

"U" shape accessory
 ERP: 3452011001 (white zinc plating)

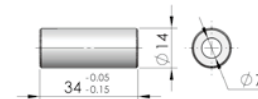

Pipe shape accessory
 ERP: 3452011013 (white zinc plating)

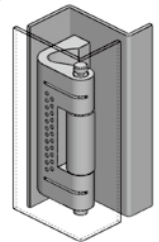

Remark: £size is 2.8, door's open angle is 90 degree.

	Black powder coated	Nanometer painted	Blast sprayed
ERP	CL201Z2A015	CL201Z2B009	CL201Z4D012

Remark: Accessory is not included in above ERP number, but optional

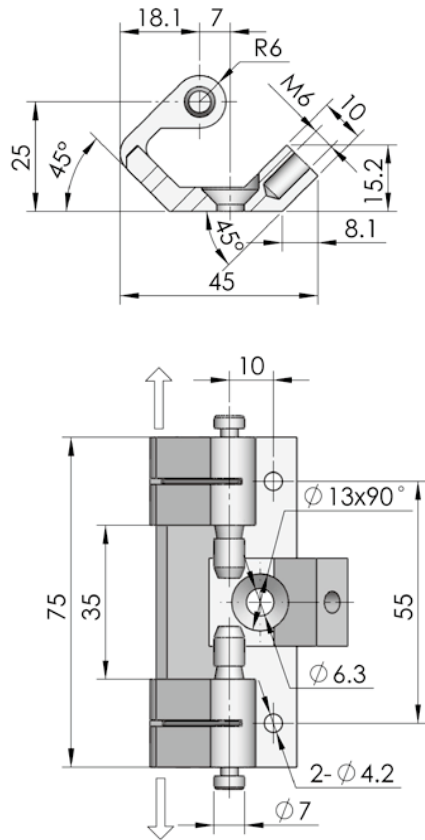

CL201-5



Main material and finish: ZDC hinge, steel pin and accessories

Performance parameter:

Maximum static load

Radial load: 700N

Axial load: 1500N

Accessories

Electronic lock

Handle lock

Cylinder lock

Plane lock

Rod control lock

Panel lock

Toggle and hook

Handles

Door stop

Hinge

Seal gasket

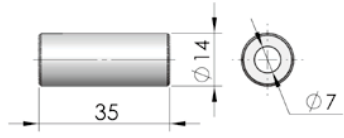

Pipe shape accessory

ERP: 3452011013 (White zinc plating)

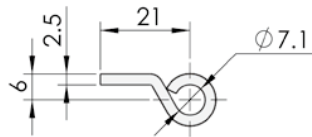

Claw shape accessory

ERP: 3452011002 (White zinc plating)

	Black powder coated	Nanometer painted	Blast sprayed
ERP	CL201Z2A013	CL201Z2B005	CL201Z4D015

Remark: Accessory is not included in above ERP number, but optional

CL201-6

Main material and finish: ZDC hinge, steel pin and accessories
 Application: Opening degree 90°

Performance parameter:
 Maximum static load
 Radial load: 900N
 Axial load: 980N

CL201-9

Main material and finish: Blast sprayed ZDC hinge leaf and steel pin.
 Application: Opening angle 120°

Performance parameter:
 Maximum static load
 Radial load: 500N
 Axial load: 800N

Accessory
 ERP: 3452016002
 (White zinc plating)

Remark: £size is 2.7, door's open angle is 90 degree.

	Nanometer painted	Blast sprayed
ERP	CL201Z2B001	CL201Z4D021

Remark: Accessory is not included in above ERP number, but optional.

Specification	With washer	Without washer
ERP	CL201Z4D064	CL201Z4D067

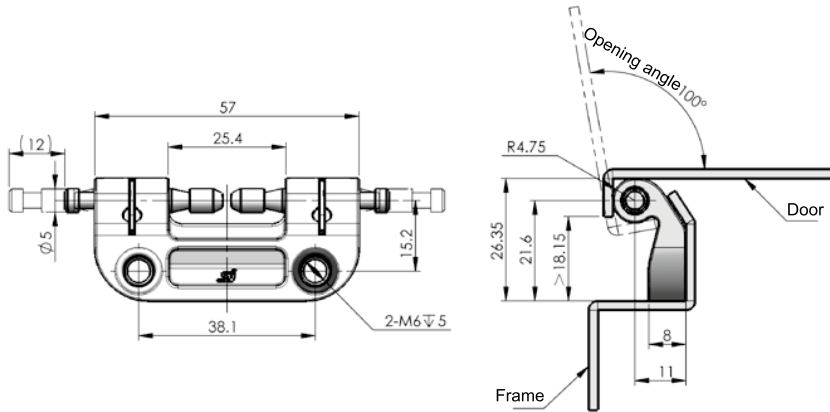

Specification	With SJ logo	Without SJ logo
ERP	CL201Z2B021	CL201Z2B022

CL201-12



Main material and finish: Nanometer painted ZDC hinge leaf, steel pin
Application: Opening angle 100°

Performance parameter:
Maximum static load
Radial load: 900N
Axial load: 2000N

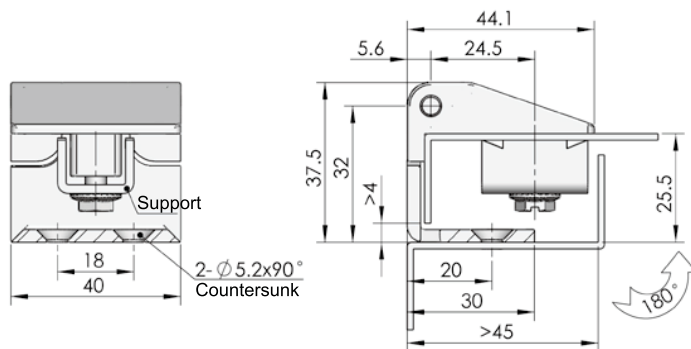

Cut size

	Black Powder Coated	Nanometer painted
ERP	CL202Z1A001	CL202Z2B001

CL202-1



Main material and finish: ZDC door-part, steel frame-part and pin
Application: Opening degree 180°

Performance parameter:
Maximum static load
Radial load: 280N
Axial load: 390N

Accessories

Electronic lock

Handle lock

Cylinder lock

Plane lock

Rod control lock

Panel lock

Toggle and hook

Handles

Door stop

Hinge

Seal gasket

- Accessories
- Electronic lock
- Handle lock
- Cylinder lock
- Plane lock
- Rod control lock
- Panel lock
- Toggle and hook
- Handles
- Door stop
- Hinge
- Seal gasket

CL202-2



Main material and finish: ZDC door-part, steel frame-part, pin and screw
 Application: Opening degree 180°

Performance parameter:
 Maximum static load
 Radial load: 560N
 Axial load: 520N

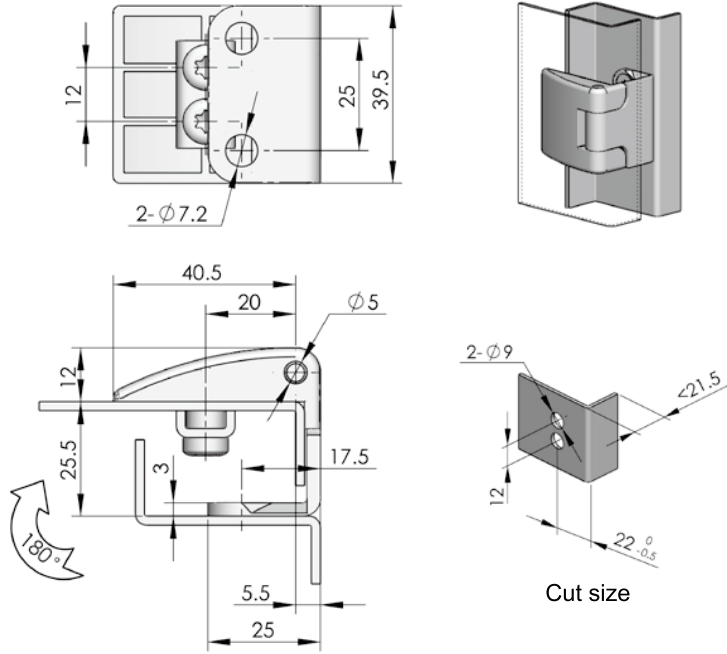

	Matt black powder coated	Malachite green powder coated	Pocked black powder coated
ERP	CL202Z1A002	CL202Z1F006	CL202Z1B001

CL203-2B



Main material and finish: ZDC hinge
 Application: Opening degree 180°

Performance parameter:
 Maximum static load
 Radial load: 600N
 Axial load: 1500N

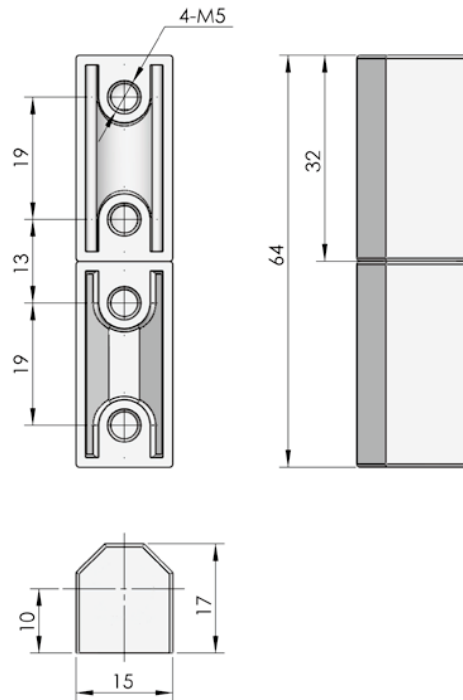

	Black powder coated	Bright chrome plated
ERP	CL203Z1A007	CL203Z3A005

CL203-1

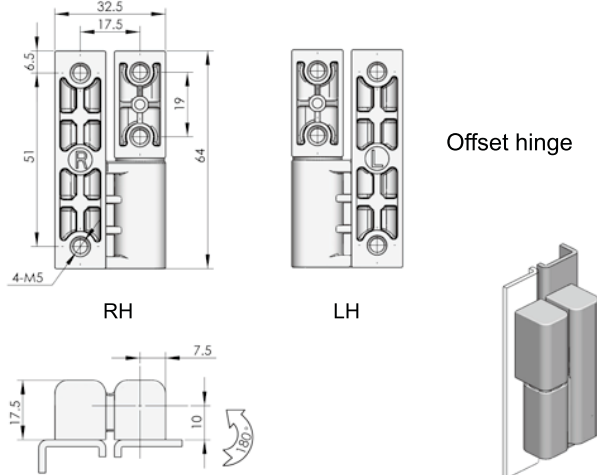

Offset hinge

CL203-2

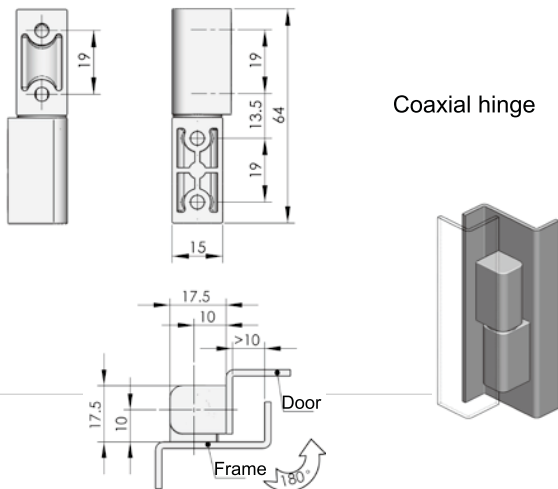

Coaxial hinge

CL203-3

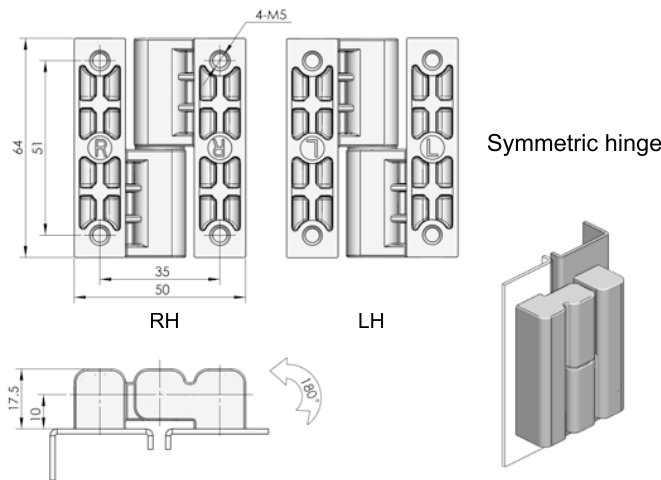

Symmetric hinge

CL203-1



CL203-2



CL203-3



Main material and finish: ZDC hinge PA bushing

Application: Opening degree 180°

Performance parameter:

Maximum static load

Model: CL203-1

Radial load: 490N Axial load: 570N

Model: CL203-2

Radial load: 650N Axial load: 1550N

Model: CL203-3

Radial load: 3300N Axial load: 880N

Specification	Model	ERP		
		Matt black powder coated	Pocked black powder coated	Nanometer painted
Coaxial hinge	CL203-2	CL203Z1A003	CL203Z1B004	CL203Z2B003
Offset left hinge	CL203-1-Z	CL203Z1A001	CL203Z1B001	CL203Z2B001
Offset right hinge	CL203-1-Y	CL203Z1A002	CL203Z1B002	CL203Z2B002
Symmetrical left hinge	CL203-3-Z	CL203Z1A008		CL203Z2B004
Symmetrical right hinge	CL203-3-Y	CL203Z1A009	CL203Z1B015	CL203Z2B005

Accessories

Electronic lock

Handle lock

Cylinder lock

Plane lock

Rod control lock

Panel lock

Toggle and hook

Handles

Door stop

Hinge

Seal gasket

Accessories

Electronic lock

Handle lock

Cylinder lock

Plane lock

Rod control lock

Panel lock

Toggle and hook

Handles

Door stop

Hinge

Seal gasket

CL203-4



Main material and finish: ZDC hinge
Application: Opening angle 180°

Performance parameter:
Maximum static load
Radial load: 270N
Axial load: 730N

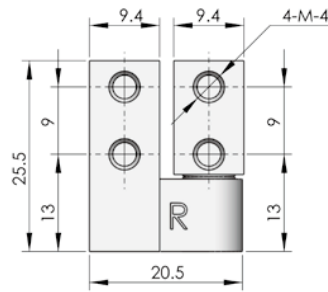

RH

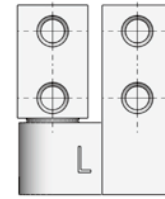

LH

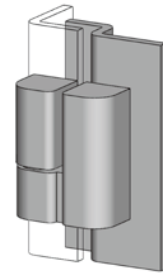
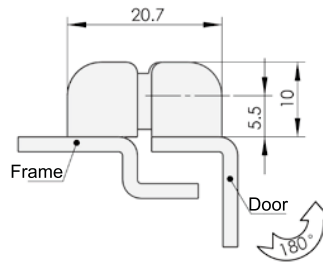

Specification	Model	ERP	
		Black powder coated	Nanometer painted
Left hand	CL203-4-Z	CL203Z2A001	CL203Z2B006
Right hand	CL203-4-Y	CL203Z2A002	CL203Z2B007

CL203-7



Main material and finish: Wiredrawing polishing stainless steel hinge
Application: Opening angle 180°

Performance parameter:
Maximum static load
Radial load: 1295N
Axial load: 2240N

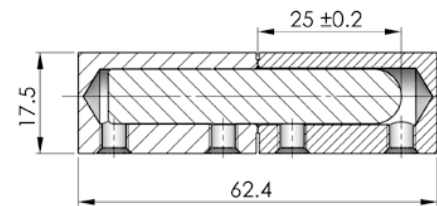
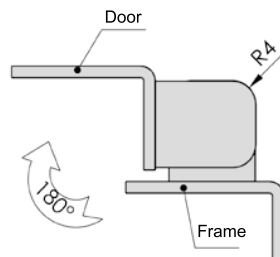
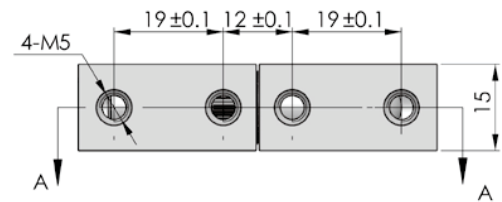
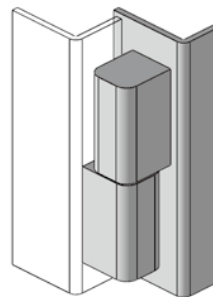

Section A-A

ERP	CL203S4B001
-----	-------------

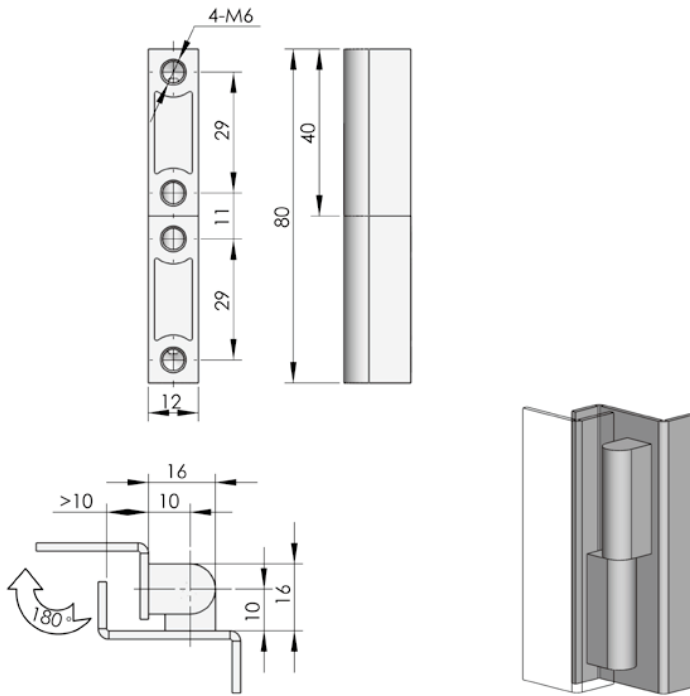

CL204-1



Main material and finish: ZDC hinge
Application: Opening angle 180°

Performance parameter:
Maximum static load
Radial load: 980N
Axial load: 2800N

	Black powder coated	Nanometer painted	Bright chrome plated
ERP	CL204Z1A001	CL204Z2B001	CL204Z3A001

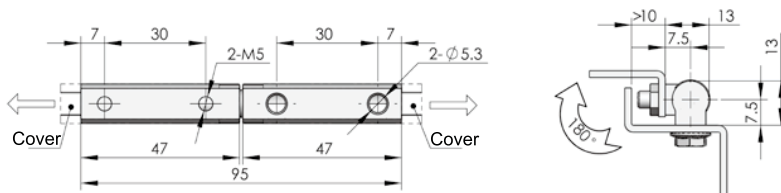

CL204-2



CL204-2
CL204-3

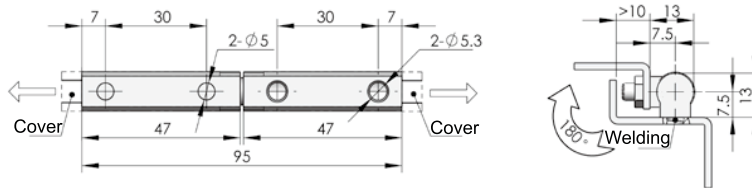

CL204-3



INOX
AISI
3..

Main material and finish: Steel hinge leaf and stainless steel cover
Application: Opening angle 180°

Performance parameter:
Maximum static load
Radial load: 1800N
Axial load: 2900N

	CL204-2 Fixed with screw	CL204-2 Welding
ERP	CL204S00001	CL204S9C001

Accessories

Electronic lock

Handle lock

Cylinder lock

Plane lock

Rod control lock

Panel lock

Toggle and hook

Handles

Door stop

Hinge

Seal gasket

Accessories

Electronic lock

Handle lock

Cylinder lock

Plane lock

Rod control lock

CL204-3C



Main material and finish: Bright chrome-plated ZDC hinge
Application: Opening angle 180°

Performance parameter:
Maximum static load
Radial load: 1000N
Axial load: 1800N

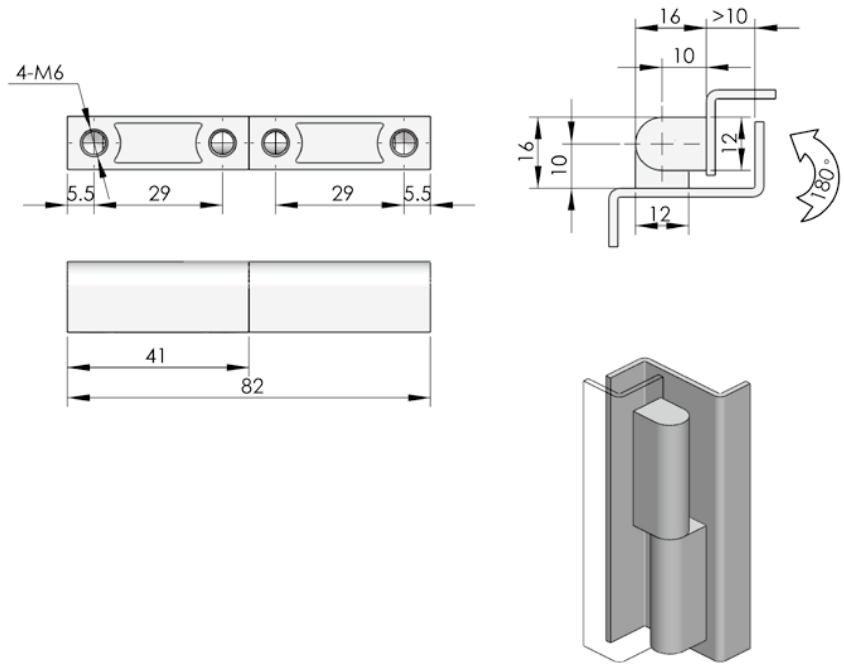

ERP CL204Z3A002

Panel lock

Toggle and hook

Handles

Door stop

Hinge

Seal gasket

CL204-3D



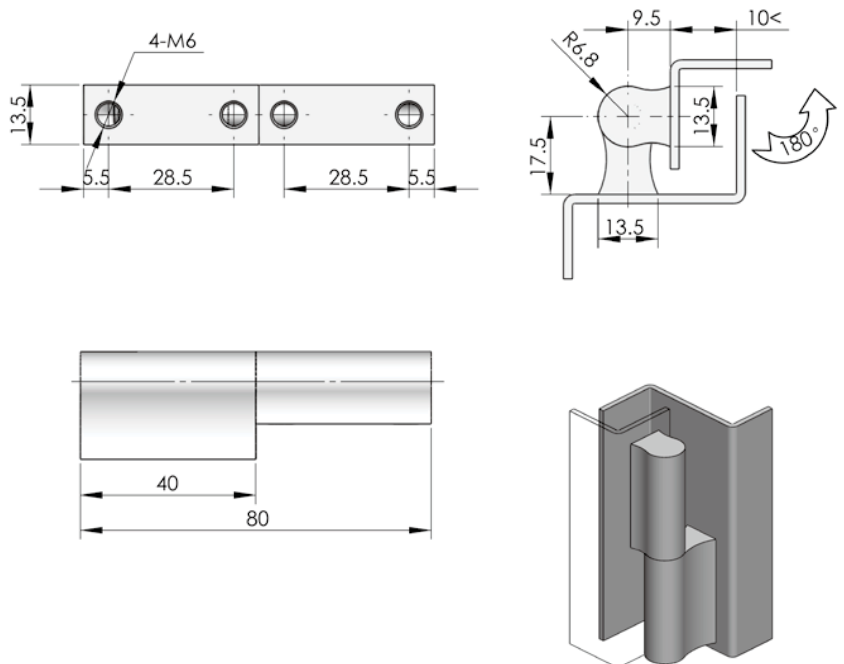

Main material and finish: Bright chrome-plated ZDC hinge
Application: Opening angle 180°

Performance parameter:
Maximum static load
Radial load: 2150N
Axial load: 2630N

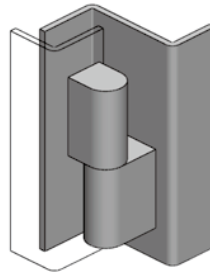
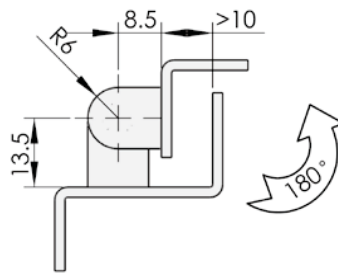
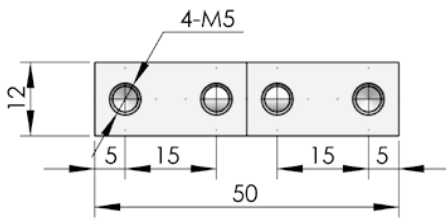

ERP CL204Z3A003



ERP

CL204Z3A007

CL204-3F



Main material and finish: Bright chrome-plated ZDC hinge
Application: Opening angle 180°

Accessories

Electronic lock

Handle lock

Cylinder lock

Plane lock

Rod control lock

CL204-3K



Main material and finish: Mirror polishing stainless steel hinge
Application: Opening angle 180°

Performance parameter:
Maximum static load
Radial load: 2000N
Axial load: 1530N

Panel lock

Toggle and hook

Handles

Door stop

Hinge

Seal gasket

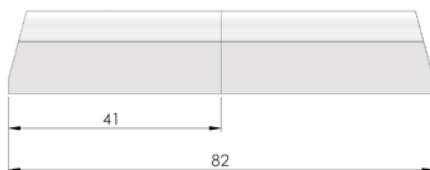
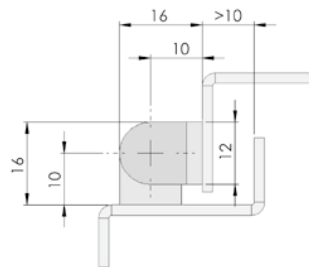
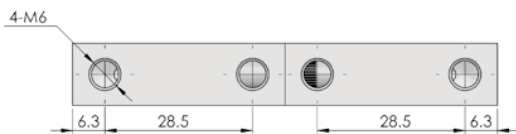

ERP

CL204S4A013

Accessories

Electronic lock

Handle lock

Cylinder lock

Plane lock

Rod control lock

Panel lock

Toggle and hook

Handles

Door stop

Hinge

Seal gasket

CL204-3S



Main material and finish: SUS304, wiredrawing polishing
Application: Opening angle 180°

Performance parameter:
Maximum static load
Radial load: 1700N
Axial load: 2200N

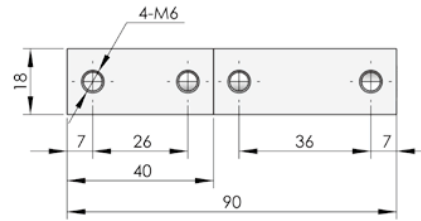

CL204-3S-2

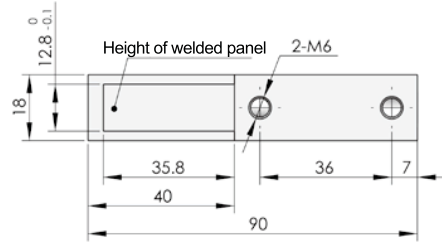
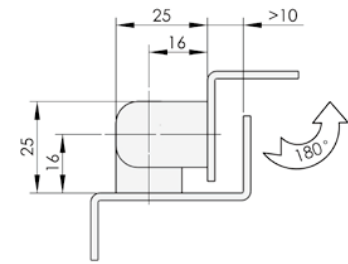

CL204-3S-1

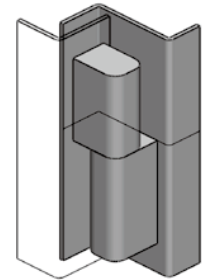

	CL204-3S-1	CL204-3S-2
ERP	CL204S4B002	CL204S4B003

CL204-4D



Main material and finish: Bright chrome plated ZDC exposed hinge
Application: Opening angle 180°

Performance parameter:
Maximum static load
Radial load: 1500N
Axial load: 2000N

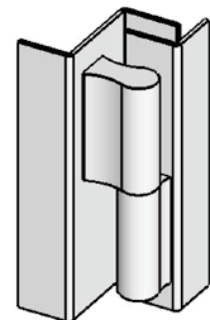
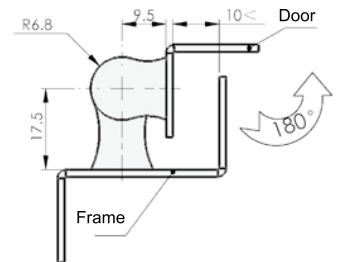
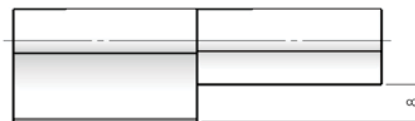
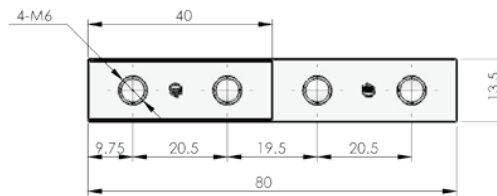

ERP	CL204Z3A013
-----	-------------

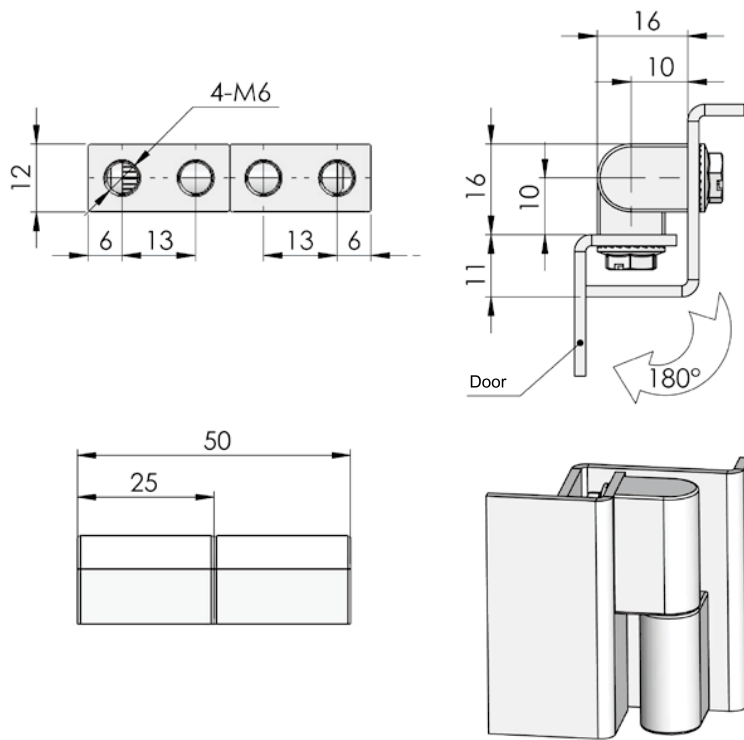

ERP CL204S4A020

CL204-7



Main material and finish: Mirror polishing
SUS304 stainless steel hinge
Application: Opening angle 180°

Performance parameter:
Maximum static load
Radial load: 1500N
Axial load: 2000N

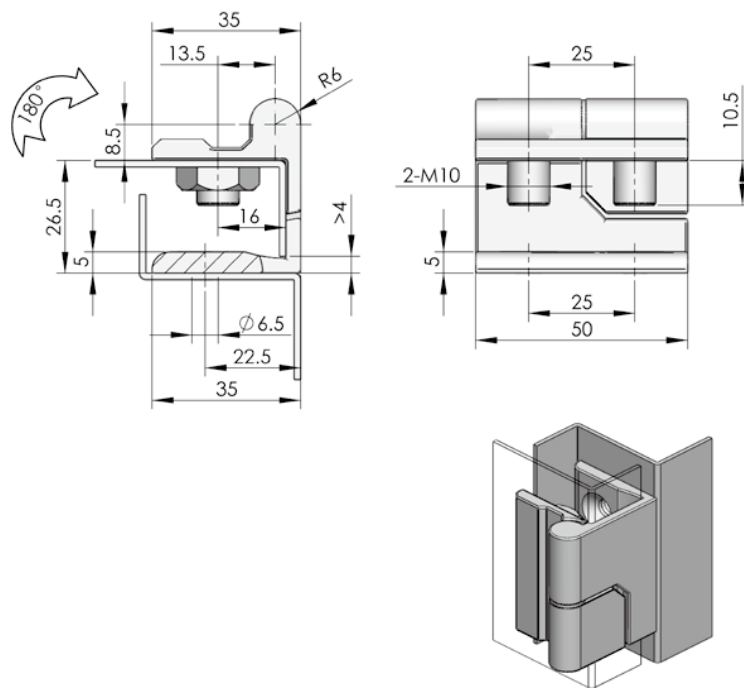

Specification	Model	ERP	
		Black powder coated	Pocked black powder coated
Left hand	CL205-1-Z	CL205Z1A001	CL205Z1B001
Right hand	CL205-1-Y	CL205Z1A002	CL205Z1B002

CL205-1



Main material and finish: ZDC hinge
Application: Opening angle 180°

Performance parameter:
Maximum static load
Radial load: 917N
Axial load: 710N



- Accessories
- Electronic lock
- Handle lock
- Cylinder lock
- Plane lock
- Rod control lock
- Panel lock
- Toggle and hook
- Handles
- Door stop
- Hinge
- Seal gasket

- Accessories
- Electronic lock
- Handle lock
- Cylinder lock
- Plane lock
- Rod control lock
- Panel lock
- Toggle and hook
- Handles
- Door stop
- Hinge
- Seal gasket

CL205-2



CL205-2-Z

CL205-2-Y



Main material and finish: ZDC hinge leaf and bushing, PA shaft
 Application: Opening angle 180°

Performance parameter:
 Maximum static load
 Radial load: 245N
 Axial load: 305N

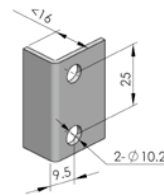
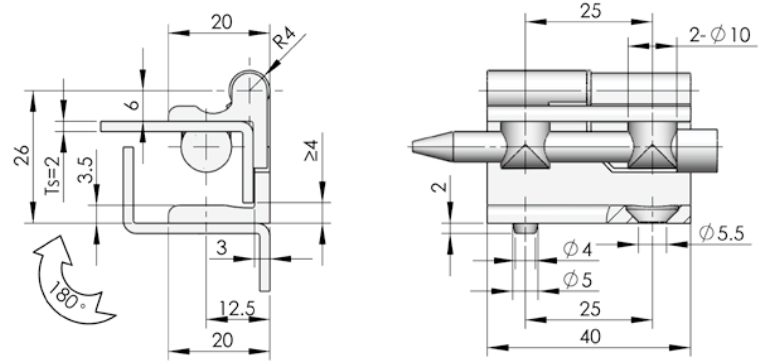

Door cutout

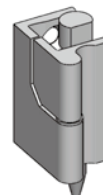

LH

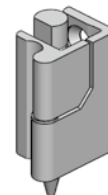

RH

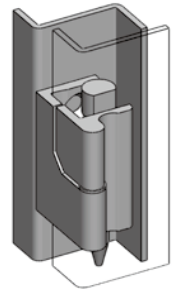

Specification	Model	ERP	
		Bright chrome-plated	Pocked black powder coated
Left hand	CL205-2-Z	CL205Z3A001	CL205Z1B003
Right hand	CL205-2-Y	CL205Z3A002	CL205Z1B004

CL206-1



Main material and finish: Bright chrome plated steel hinge, steel gasket
 Application: Opening angle 180°

Performance parameter:
 Maximum static load
 Radial load: 2500N
 Axial load: 1785N

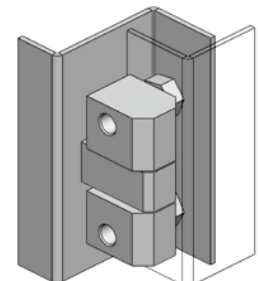
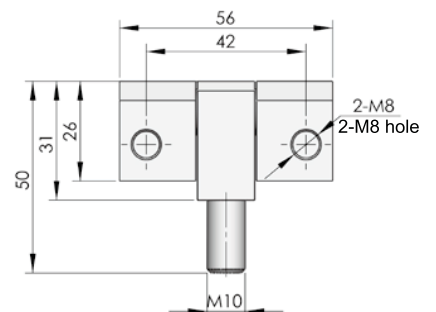
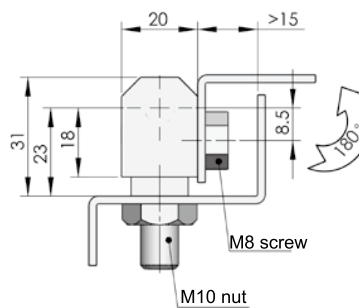

ERP	CL206F3A001
-----	-------------

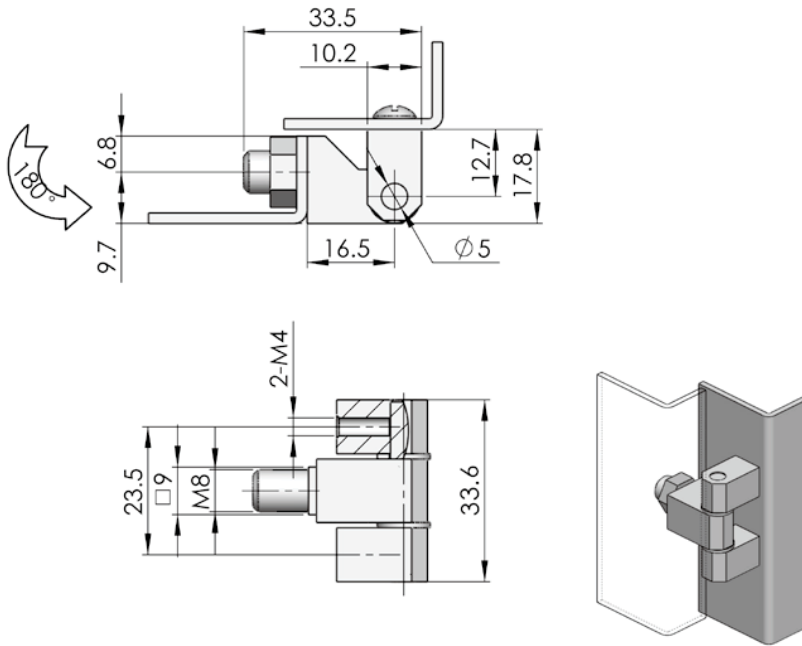

	Black powder coated	Bright chrome-plated
ERP	CL206Z1A001	CL206Z3A007

CL206-2



Main material and finish: ZDC hinge, steel pin
Application: Opening angle 180°

Performance parameter:
Maximum static load
Radial load: 1200N
Axial load: 1000N

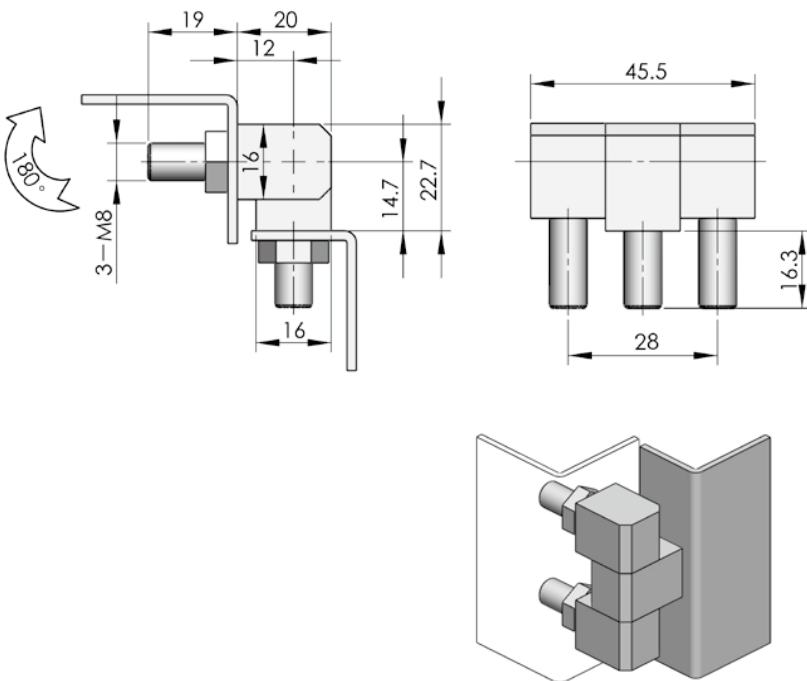

	Pocked black powder coated	Black painted	Bright chrome plated
ERP	CL206F1B001	CL206F2A001	CL206F3A008

CL206-3



Main material and finish: Bright chrome plated steel hinge and gasket
Application: Opening angle 180°

Performance parameter:
Maximum static load
Radial load: 2000N
Axial load: 1500N

Accessories

Electronic lock

Handle lock

Cylinder lock

Plane lock

Rod control lock

Panel lock

Toggle and hook

Handles

Door stop

Hinge

Seal gasket

Accessories

CL206-3B



Electronic lock

Handle lock



Cylinder lock

Main material and finish: ZDC hinge
Application: Opening angle 180°

Plane lock

Performance parameter:
Maximum static load
Radial load: 2000N
Axial load: 1520N
Embedded screw recommended
tightening torque : 50N.m

Rod control lock

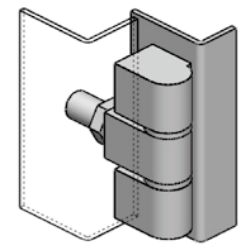
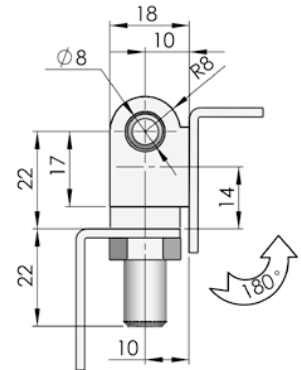
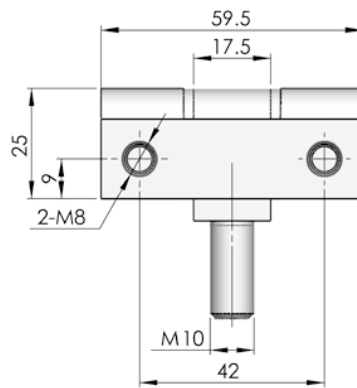

	Black painted	Bright chrome-plated
ERP	CL206Z2A002	CL206Z3A011

Panel lock

CL206-4



Toggle and hook

Handles



Door stop

Main material and finish: ZDC hinge, steel pin
Application: Opening angle 180°

Hinge

Performance parameter:
Maximum static load
Radial load: 1200N
Axial load: 1000N

Seal gasket

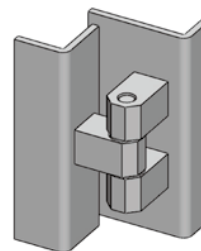
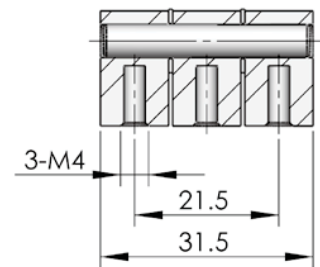
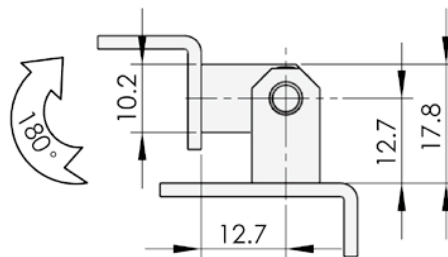

	Black powder coated	Bright chrome-plated
ERP	CL206Z1A003	CL206Z3A012

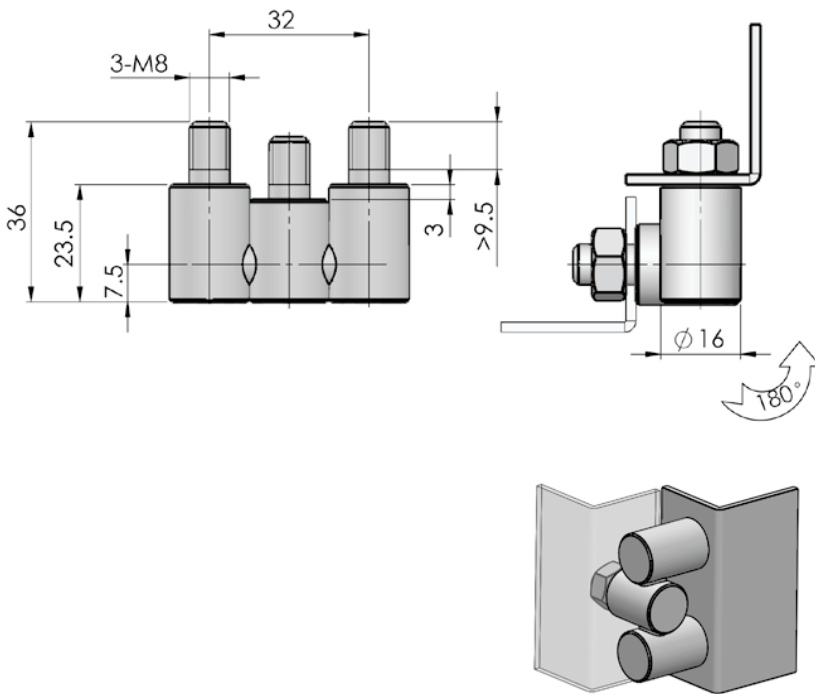

ERP CL206S4B002

CL206-12



Main material and finish: Wiredrawing polishing SUS316 stainless steel hinge
Application: Opening angle 180°

Performance parameter:
Maximum static load
Radial load: 1500N
Axial load: 2000N

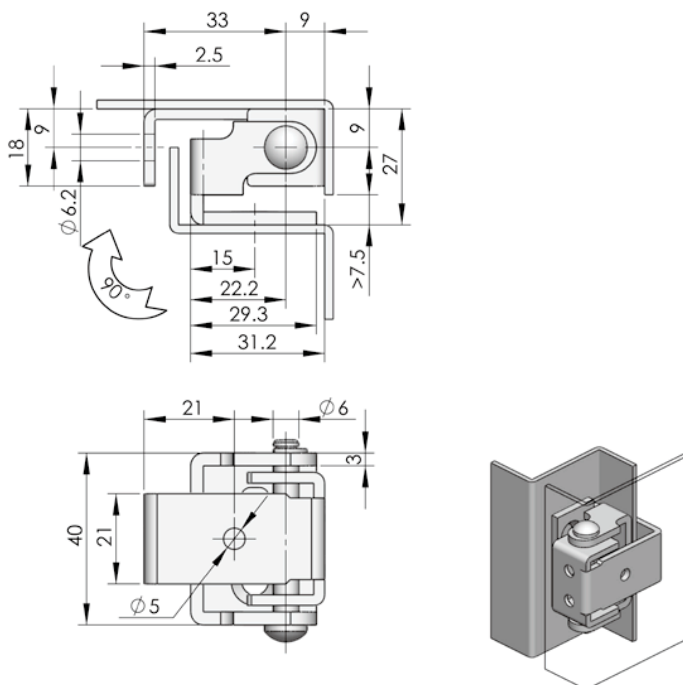

ERP CL207F3D001

CL207



Main material and finish: White zinc-plated steel hinge
Application: Opening angle 90°

Performance parameter:
Maximum static load
Radial load: 170N
Axial load: 190N

Accessories
Electronic lock
Handle lock
Cylinder lock
Plane lock
Rod control lock
Panel lock
Toggle and hook
Handles
Door stop
Hinge
Seal gasket

Accessories

CL208



Electronic lock

Handle lock



Cylinder lock

Main material and finish: ZDC hinge, steel support and screw
Application: Opening angle 180°

Plane lock

Performance parameter:
Maximum static load
Radial load: 240N
Axial load: 520N

Rod control lock

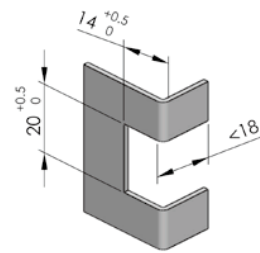
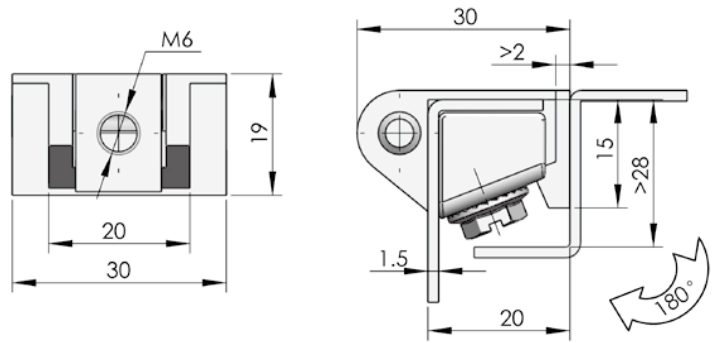

Door cutout

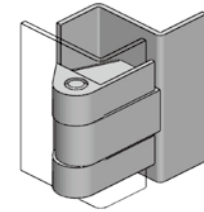

	Matt black powder coated	Nanometer painted	Bright chrome-plated
ERP	CL208Z1A001	CL208Z2B001	CL208Z3A001

Panel lock

CL209-1C



Toggle and hook

Handles



Door stop

Main material and finish: Nanometer painted ZDC hinge, stainless steel shaft and screw
Application: Opening angle 180°

Hinge

Performance parameter:
Maximum static load
Radial load: 1800N
Axial load: 1350N

Seal gasket

Embedded screw recommended
tightening torque : 9N.m

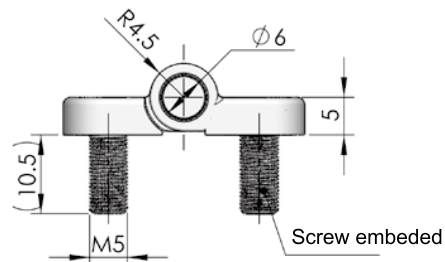
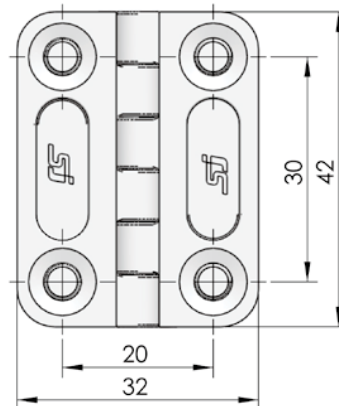

ERP	CL209Z2B004
-----	-------------

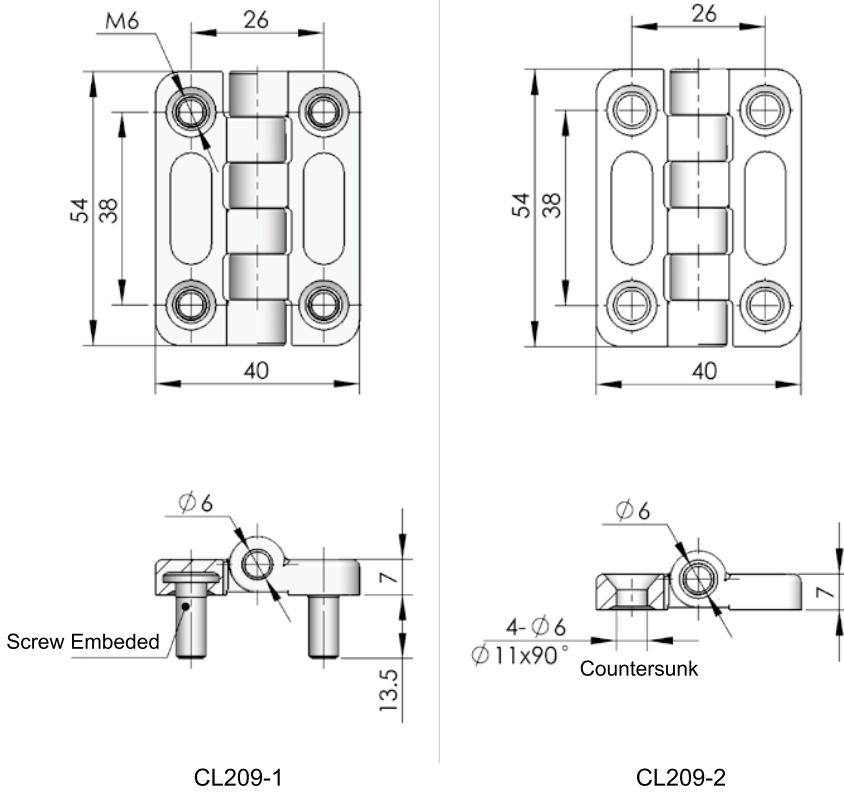

CL209-1



CL209-2



Main material and finish: ZDC hinge and steel pin
 Application: Opening angle 180°

Performance parameter:
 Maximum static load
 Radial load: 1500N
 Axial load: 1800N
 Embedded screw recommended
 tightening torque : 10N.m

Specification	ERP	
	CL209-1	CL209-2
Bright chrome-plated	CL209Z3A001	CL209Z3A002
Matt black powder coated	CL209Z1A001	CL209Z1A015
Pocked black powder coated	CL209Z1B001	CL209Z1B002
Nanometer painted	CL209Z2B001	CL209Z2B006

- Accessories
- Electronic lock
- Handle lock
- Cylinder lock
- Plane lock
- Rod control lock
- Panel lock
- Toggle and hook
- Handles
- Door stop
- Hinge
- Seal gasket

- Accessories
- Electronic lock
- Handle lock
- Cylinder lock
- Plane lock
- Rod control lock
- Panel lock
- Toggle and hook
- Handles
- Door stop
- Hinge
- Seal gasket

CL210



Main material and finish: ZDC hinge, steel pin, PA gasket set
 Application: Opening angle 110°

Performance parameter:
 Maximum static load
 Radial load: 720N
 Axial load: 830N

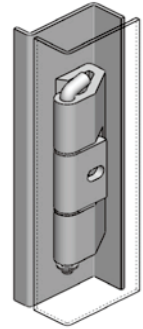
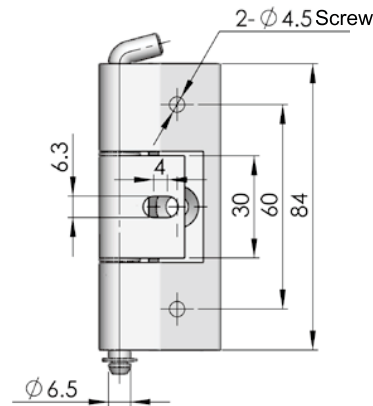
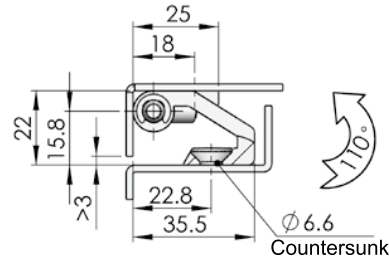

	Matt black powder coated	Nanometer painted
ERP	CL210Z1A001	CL210Z2B001

CL211



Main material and finish: Black powder coated ZDC hinge, nickel-plated steel pin
 Application: Opening angle 180°

Performance parameter:
 Maximum static load
 Radial load: 1500N
 Axial load: 1800N

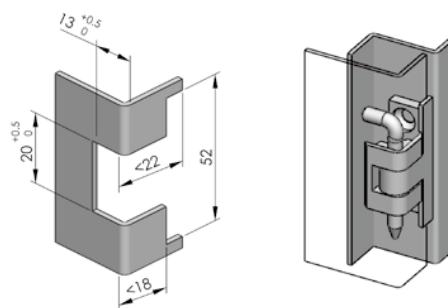
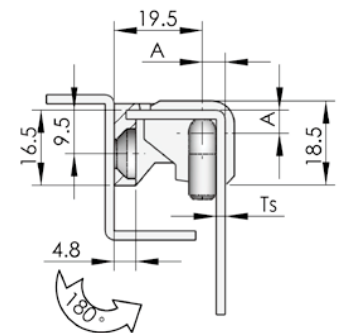
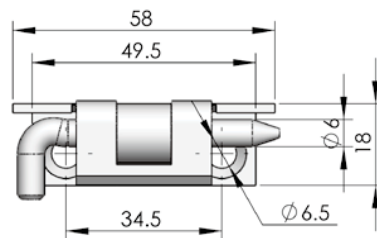

Door cutout

Optional nylon pin

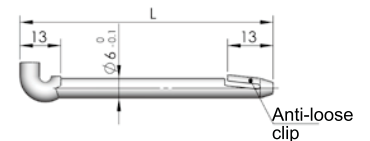

Part No.	L
PN001	57
PN002	78

Specification	A	Model	ERP
Suitable door thickness, Ts=1.5mm	4.6	CL211-1	CL211Z1A001
Suitable door thickness, Ts=2mm	5.1	CL211-2	CL211Z1A010

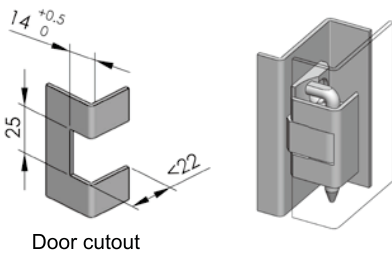
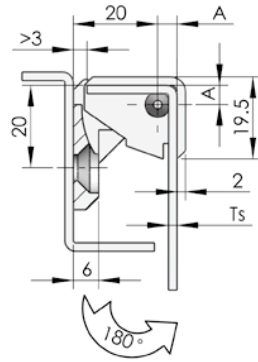
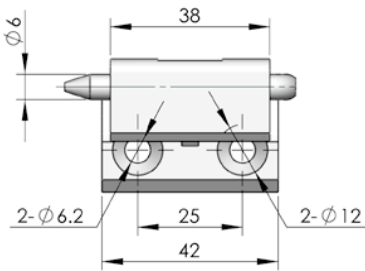

Optional nylon pin

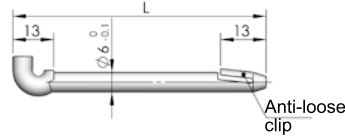

Part No.	L
PN001	57
PN002	78

CL212



Main material and finish: Black powder coated ZDC hinge, nickel-plated steel pin
Application: Opening angle 180°

Performance parameter:
Maximum static load
Radial load: 1050N
Axial load: 980N

Specification	A	Model	ERP
Suitable door thickness, Ts=2mm	5.1	CL212-1	CL212Z1A001
Suitable door thickness, Ts=3mm	6.1	CL212-2	CL212Z1A003
Suitable door thickness, Ts=1.5mm	4.6	CL212-3	CL212Z1A004

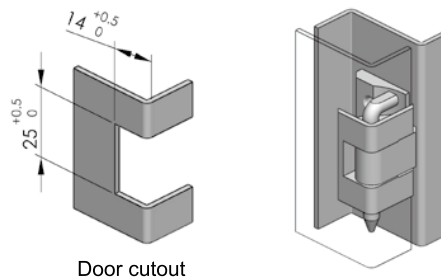
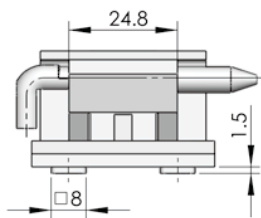

Door cutout

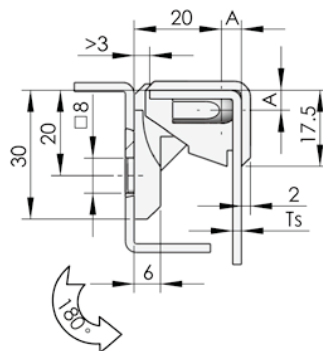
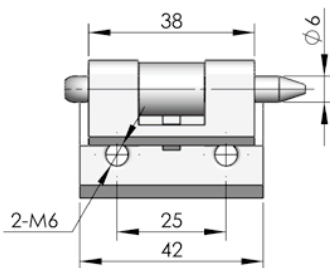

CL212-1B/2B/3B



Main material and finish: Black powder coated ZDC hinge, nickel-plated steel pin
Application: Opening angle 180°

Performance parameter:
Maximum static load
Radial load: 1050N
Axial load: 980N

ERP	Specification	A
CL212Z1A007	Suitable door thickness, Ts=2mm	5.1
CL212Z1A008	Suitable door thickness, Ts=3mm	6.1
CL212Z1A009	Suitable door thickness, Ts=1.5mm	4.6

Accessories

Electronic lock

Handle lock

Cylinder lock

Plane lock

Rod control lock

Panel lock

Toggle and hook

Handles

Door stop

Hinge

Seal gasket

- Accessories
- Electronic lock
- Handle lock
- Cylinder lock
- Plane lock
- Rod control lock
- Panel lock
- Toggle and hook
- Handles
- Door stop
- Hinge
- Seal gasket

CL212-F



Main material and finish: Black nylon hinge
 Application: Opening angle 90°

Performance parameter:
 Maximum static load
 Radial load: 77N
 Axial load: 105N

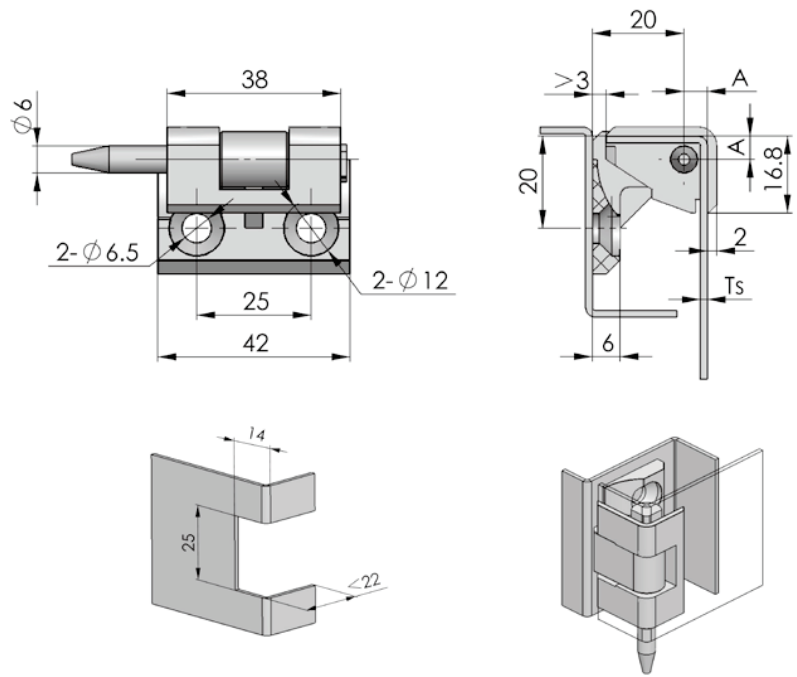

Specification	A	ERP
Suitable door thickness Ts=1.0mm	4.4	CL212N00001
Suitable door thickness Ts=1.5mm	5.1	CL212N00002

CL212-3A



Main material and finish: Black powder coated ZDC hinge, nickel-plated steel pin
 Application: Opening angle 180°

Performance parameter:
 Maximum static load
 Radial load: 1050N
 Axial load: 980N

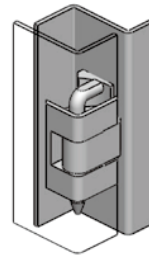
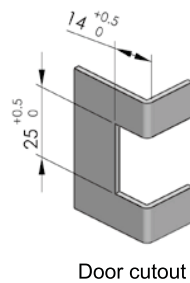
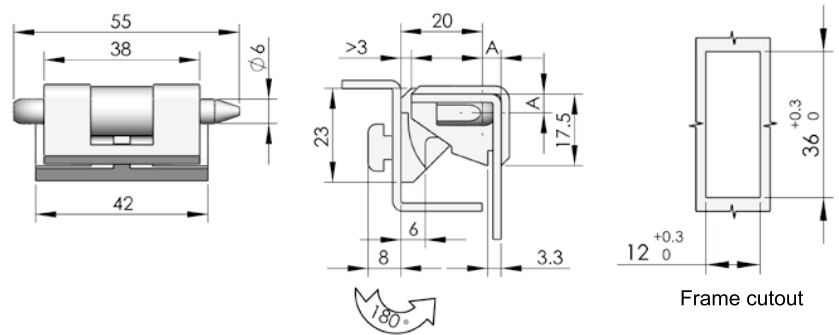

Optional nylon pin

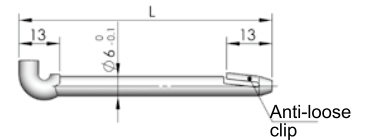

Part No.	L
PN001	57
PN002	78

ERP	Specification	A
CL212Z1A002	Suitable door thickness, Ts=2mm	5.1
CL212Z1A005	Suitable door thickness, Ts=3mm	6.1
CL212Z1A006	Suitable door thickness, Ts=1.5mm	4.6

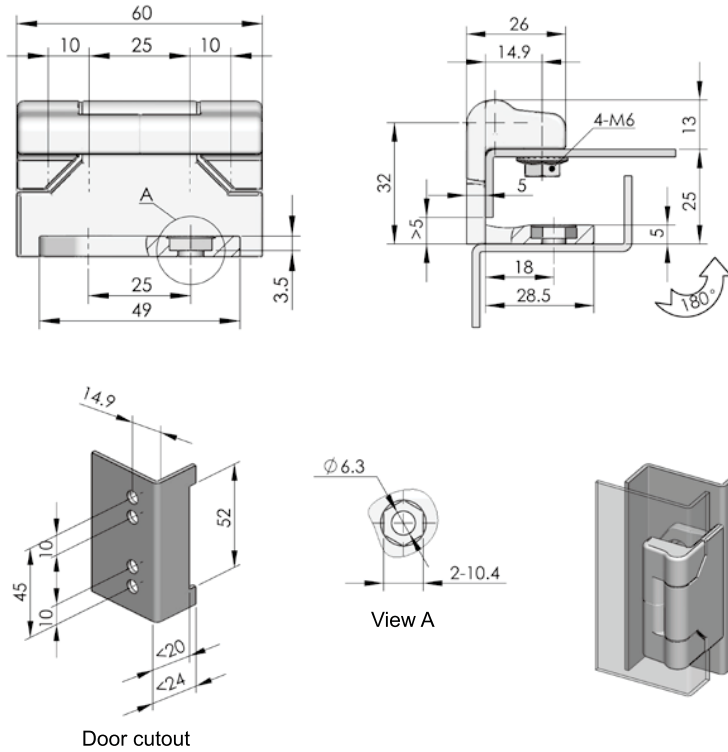

ERP

CL213Z1A001

CL213-1



Main material and finish: Black powder coated ZDC hinge, black-plated steel pin, brass gasket
Application: Opening angle 180°

Performance parameter:
Maximum static load
Radial load: 980N
Axial load: 630N

Accessories

Electronic lock

Handle lock

Cylinder lock

Plane lock

Rod control lock

Panel lock

Toggle and hook

Handles

Door stop

Hinge

Seal gasket

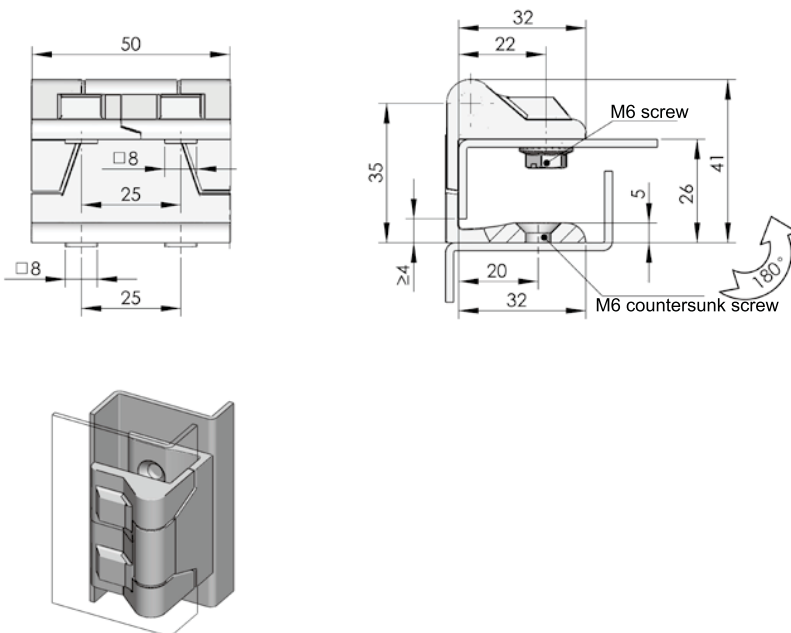

ERP

Black powder coated

CL213Z1A003

Pocked black powder coated

CL213Z1B002

CL213-2



Main material and finish: ZDC hinge, brass gasket and steel pin
Application: Opening angle 180°

Performance parameter:
Maximum static load
Radial load: 575N
Axial load: 1030N

- Accessories
- Electronic lock
- Handle lock
- Cylinder lock
- Plane lock
- Rod control lock
- Panel lock
- Toggle and hook
- Handles
- Door stop
- Hinge**
- Seal gasket

CL213-3



Main material and finish: ZDC hinge, PA shaft

Application: Opening angle 180°

Performance parameter:

Maximum static load

Radial load: 670N

Axial load: 255N

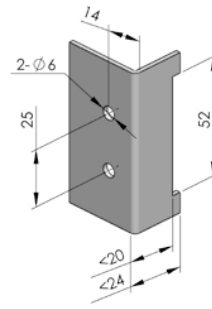
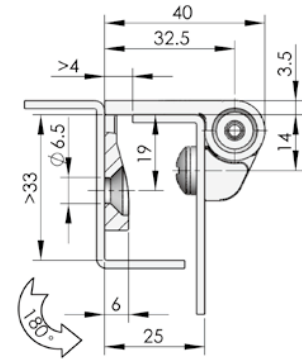
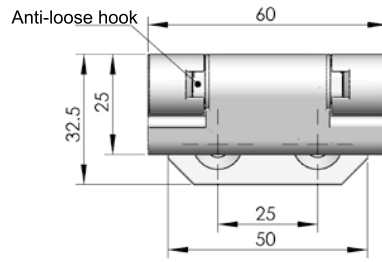

Door cutout

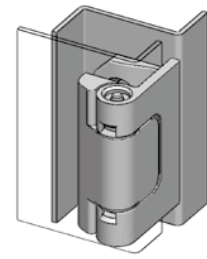

	Black powder coated	Pocked black powder coated
ERP	CL213Z1A004	CL213Z1B003

CL213-6



Main material and finish: Black powder coated hinge, brass washer and steel pin

Application: Opening angle 180°

Performance parameter:

Maximum static load

Radial load: 1225N

Axial load: 775N

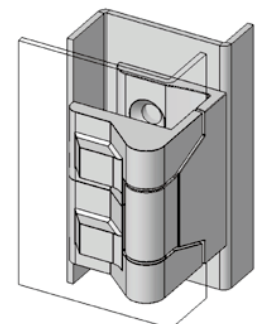
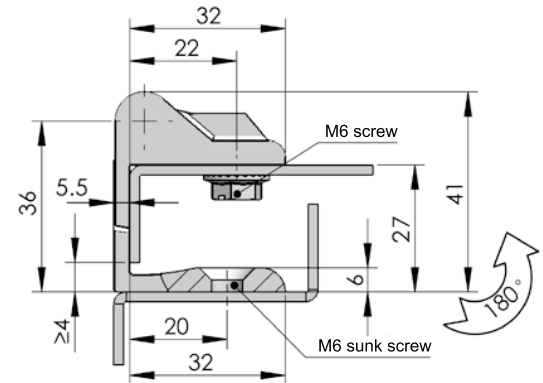
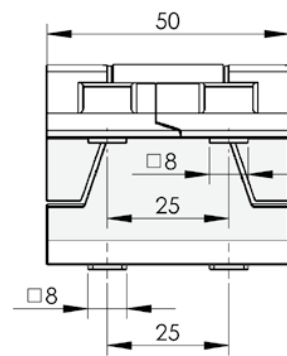

ERP	CL213Z1A007
-----	-------------

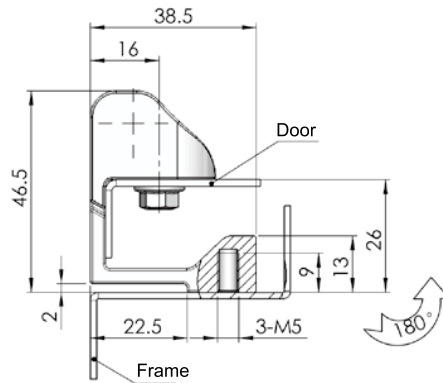
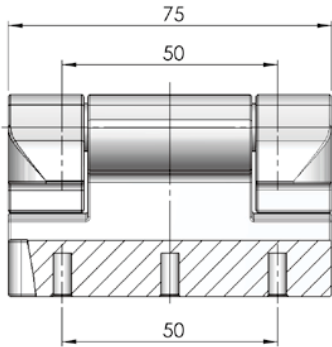

ERP

CL213ZXX003

CL213-7



Main material and finish: Powder coated ZDC half-concealed hinge
Application: Opening angle 180°

Performance parameter:
Maximum static load
Radial load: 680N
Axial load: 1225N

Accessories

Electronic lock

Handle lock

Cylinder lock

Plane lock

Rod control lock

Panel lock

Toggle and hook

Handles

Door stop

Hinge

Seal gasket

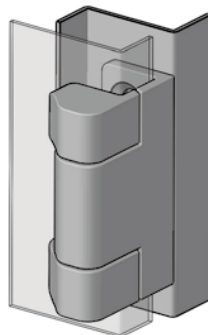
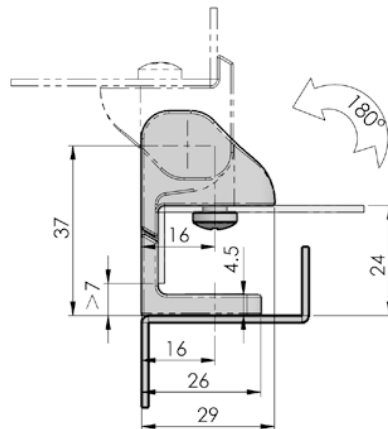
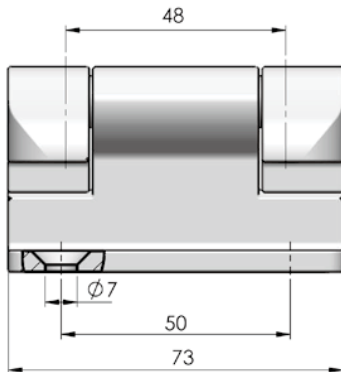

ERP

CL213ZXX007

CL213-9



Main material and finish: Orange-peel (RAL7035) powder coated ZDC hinge leaf and stainless steel pin
Application: Opening angle 180°

Performance parameter:
Maximum static load
Radial load: 320N
Axial load: 350N



Accessories

Electronic lock

Handle lock

Cylinder lock

Plane lock

Rod control lock

Panel lock

Toggle and hook

Handles

Door stop

Hinge

Seal gasket

CL214



Main material and finish: ZDC hinge and steel pin
Application: Opening angle 180°

Performance parameter:
Maximum static load
Radial load: 1125N
Axial load: 1490N

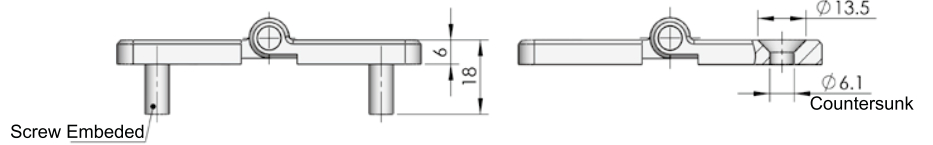
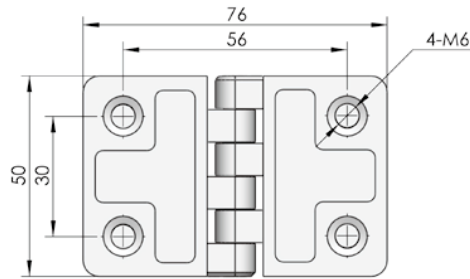

Specification	ERP	
	CL214-1	CL214-2
Bright chrome-plated	CL214Z3A001	CL214Z3A002
Matt black powder coated	CL214Z1A001	CL214Z1A003
Pocked black powder coated	CL214Z1B001	CL214Z1B002
Nanometer painted	CL214Z2B001	CL214Z2B002

Panel lock

Toggle and hook

Handles

Door stop

Hinge

Seal gasket

CL215



Main material and finish: White zinc plated steel hinge, PA washer
Application: Opening angle 180°

Performance parameter:
Maximum static load
Radial load: 750N
Axial load: 850N

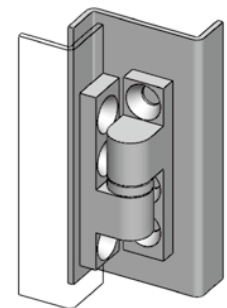
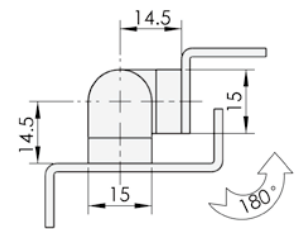
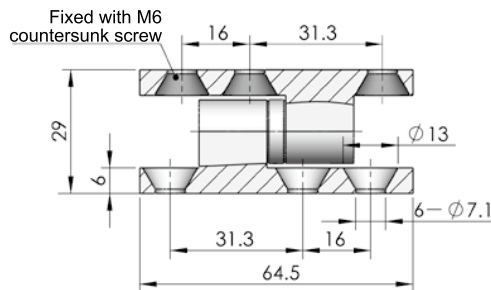

ERP	CL215F3D001
-----	-------------

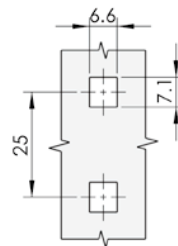
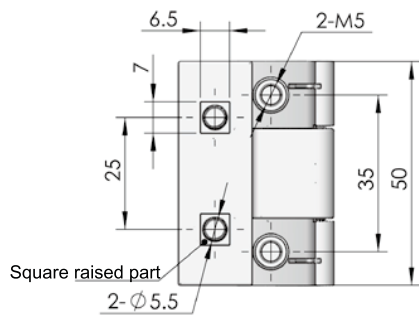

Frame cutout

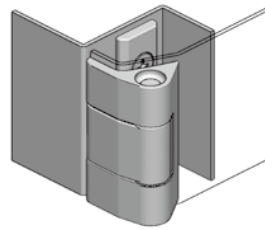
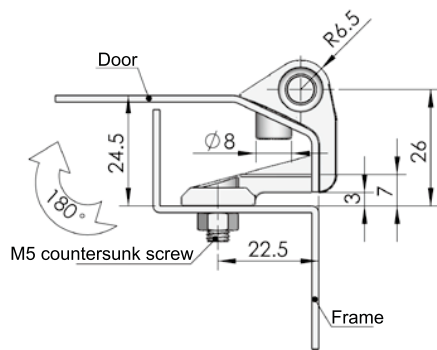

ERP

CL216Z1A001

CL216



Main material and finish: Black powder coated ZDC hinge, nickel-plated steel pin
Application: Opening angle 180°

Performance parameter:
Maximum static load
Radial load: 570N
Axial load: 480N

Accessories

Electronic lock

Handle lock

Cylinder lock

Plane lock

Rod control lock

Panel lock

Toggle and hook

Handles

Door stop

Hinge

Seal gasket

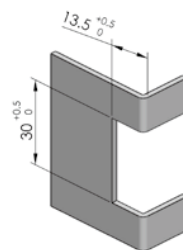
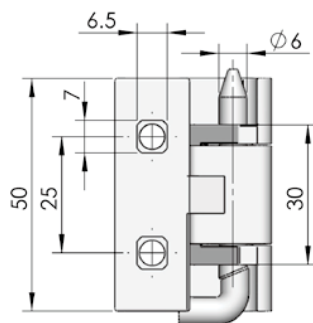

Door cutout

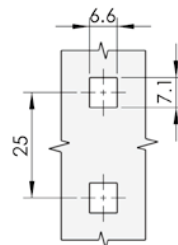
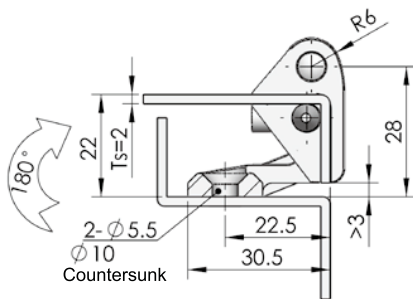

Frame cutout

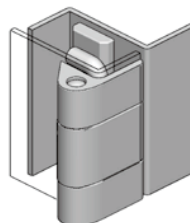

ERP

CL217Z1A001

CL217



Main material and finish: Black powder coated ZDC hinge, nickel-plated steel pin
Application: Opening angle 180°

Performance parameter:
Maximum static load
Radial load: 550N
Axial load: 470N

Accessories
Electronic lock
Handle lock
Cylinder lock
Plane lock
Rod control lock
Panel lock
Toggle and hook
Handles
Door stop
Hinge
Seal gasket

CL218



Main material and finish: White zinc-plated steel hinge
 Application: Opening angle 90°

Performance parameter:
 Maximum static load
 Radial load: 570N
 Axial load: 780N

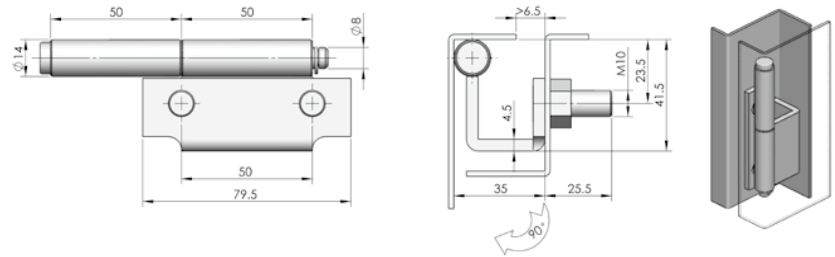

CL218-1

ERP CL218F3D001

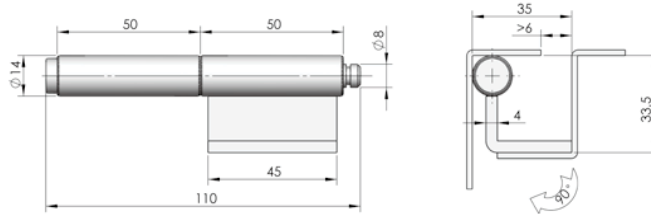

CL218-2

ERP CL218F3D002

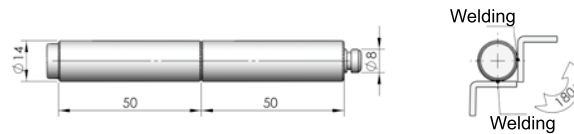

CL218-3

ERP CL218F3D003

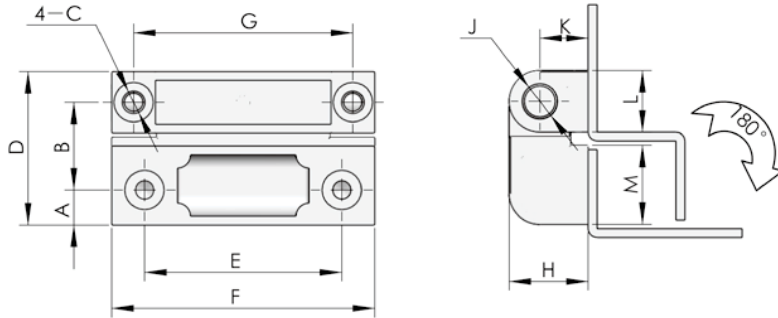

O-ring seals onto the screw holes will be provided if required

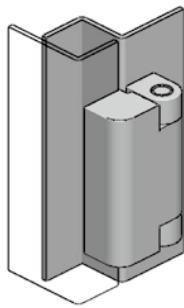

O-ring seals onto the screw holes will be provided if required

ERP	Specification												
	Structure	A	B	C	D	E	F	G	H	J	K	L	M
CL219Z1A001	Non-damping	8	20	M5	35	45	60	50	18	∅8	11	14	18
CL219Z1A005	Non-damping	4	13	M4	22	22	30	22	13	∅5	8	10	9
CL219Z1A007	Non-damping	4	18.5	M4	27.5	22	30	22	13	∅5	8	10	14.5

CL219



Main material and finish: Black powder coated ZDC hinge, nickel-plated steel pin
 Application: Opening angle 180°

Performance parameter:
 Maximum static load

Model: CL219-1
 Radial load: 1000N
 Axial load: 1200N

Model: CL219-2
 Radial load: 600N
 Axial load: 460N

Model: CL219-3
 Radial load: 700N
 Axial load: 800N

Accessories

Electronic lock

Handle lock

Cylinder lock

Plane lock

Rod control lock

Panel lock

Toggle and hook

Handles

Door stop

Hinge

Seal gasket

Accessories

CL220



Electronic lock

Handle lock



Cylinder lock

Main material and finish: Gray chrome-plated ZDC hinge, nickel-plated steel pin

Performance parameter:
 Maximum static load
 Radial load: 290N
 Axial load: 160N

Plane lock

Rod control lock

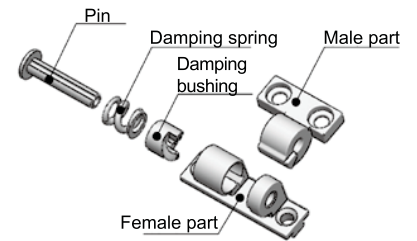
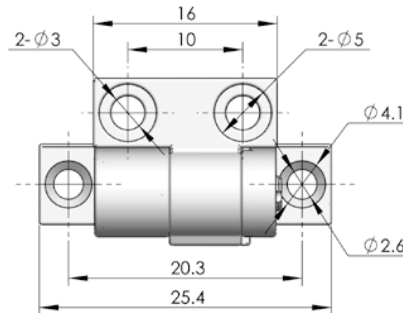
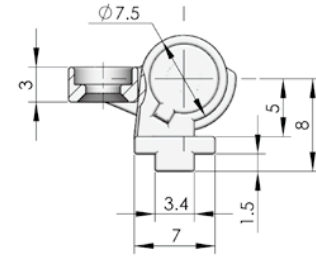
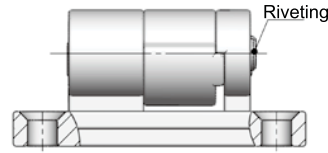

ERP

CL220Z3B001

Panel lock

CL221



Toggle and hook

Handles



Door stop

Main material and finish: Nanometer painted ZDC hinge

Performance parameter:
 Maximum static load
 Radial load: 55N
 Axial load: 75N

Hinge

Seal gasket

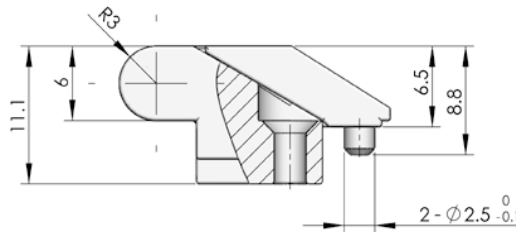
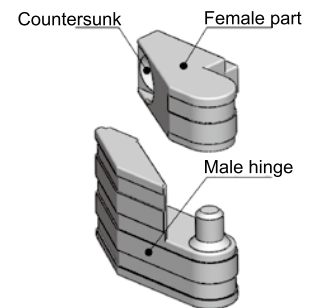
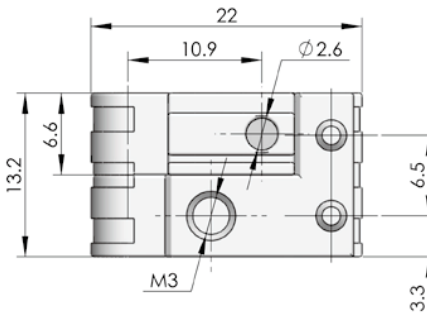

ERP

Specification

CL221Z2B001

LH applicable

CL221Z2B002

RH applicable

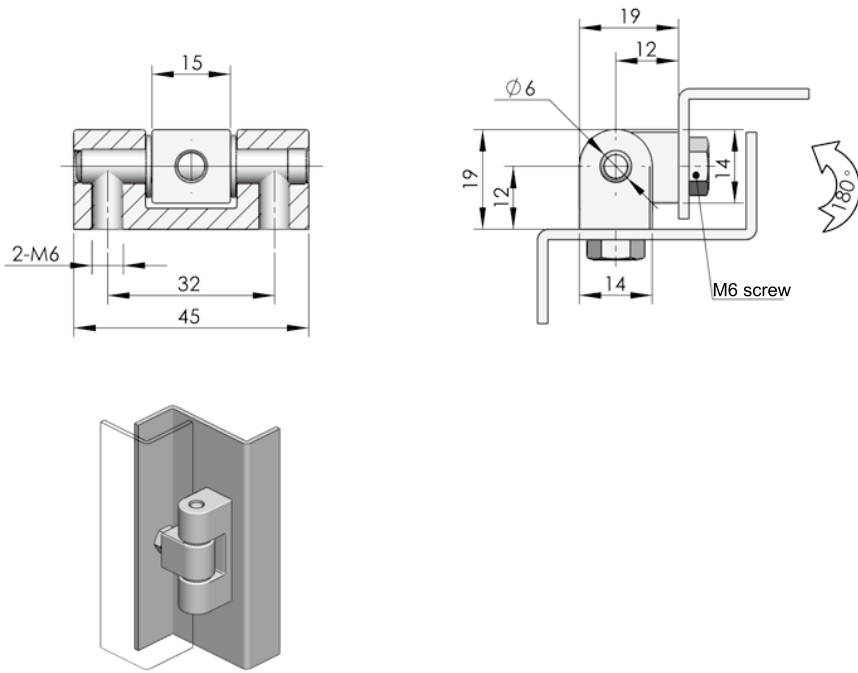

	Black powder coated	Pocked black powder coated	Bright chrome-plated	Nanometer painted
ERP	CL222Z1A001	CL222Z1B001	CL222Z3A001	CL222Z2B002

CL222



Main material and finish: ZDC hinge, nickel-plated steel pin, PA bushing
Application: Opening angle 180°

Performance parameter:
Maximum static load
Radial load: 1675N
Axial load: 2000N

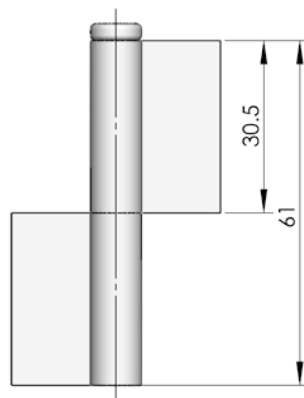
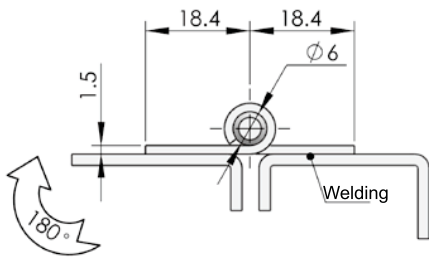

ERP	CL223F3D001
-----	-------------

CL223



Main material and finish: White zinc plated steel hinge leaf
Application: Opening angle 180°

Performance parameter:
Maximum static load
Radial load: 390N
Axial load: 1260N

Accessories

Electronic lock

Handle lock

Cylinder lock

Plane lock

Rod control lock

Panel lock





Toggle and hook

Handles

Door stop

Hinge

Seal gasket

Accessories	CL225
Electronic lock	 CL225-1
Handle lock	 CL225-1A
Cylinder lock	 CL225-2
Plane lock	
Rod control lock	
Panel lock	
Toggle and hook	<p>Main material and finish: White zinc plated steel hinge leaf</p> <p>Performance parameter: Maximum static load</p> <p>Model: CL225-1/1A Radial load: 150N Axial load: 200N</p> <p>Model: CL225-2 Radial load: 100N Axial load: 130N</p>
Hinge	
Seal gasket	

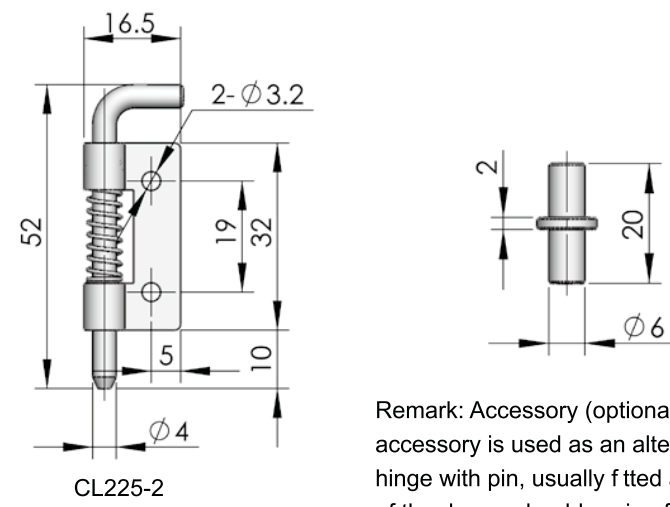
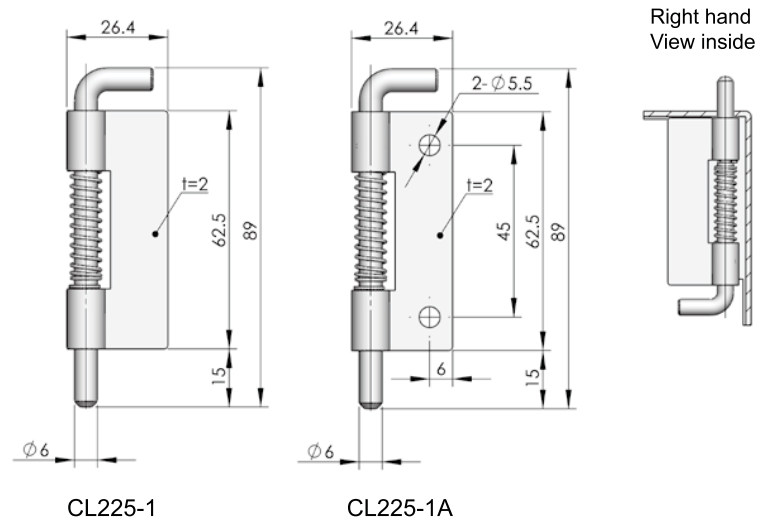

Remark: Accessory (optional) This accessory is used as an alternative to the hinge with pin, usually fitted at the bottom of the door as load-bearing fixing door

LH		RL		Specification
Model	ERP	Model	ERP	
CL225-1-Z	CL225F3D001	CL225-1-Y	CL225F3D004	Standard type: white zinc plated steel hinge. A means hinge with two mounting holes, S means grinding vibration polishing stainless steel hinge.
CL225-1-S-Z	CL225S00001	CL225-1-S-Y	CL225S00002	
CL225-1A-Z	CL225F3D008	CL225-1A-Y	CL225F3D007	
CL225-1A-S-Z	CL225S00010	CL225-1A-S-Y	CL225S00011	
CL225-2-Z	CL225F3D011	CL225-2-Y	CL225F3D012	White zinc plated steel hinge with two mounting holes

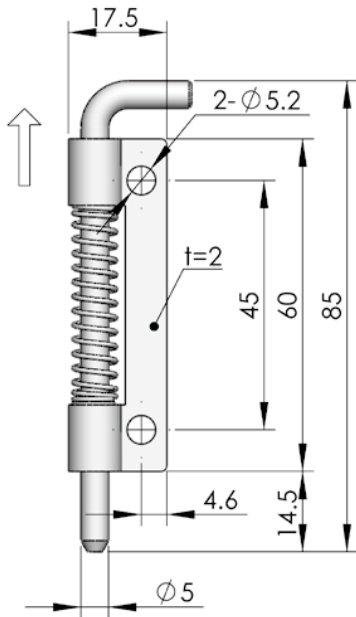

	LH	RH
ERP	CL225F3D022	CL225F3D019

CL225-3



Main material and finish: White zinc plated steel hinge leaf

Performance parameter:

Maximum static load

Radial load: 150N

Axial load: 250N

Exploded drawing

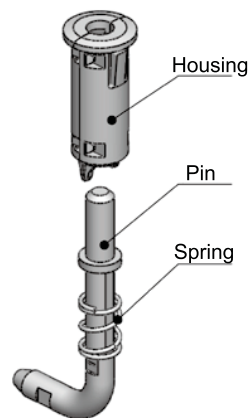
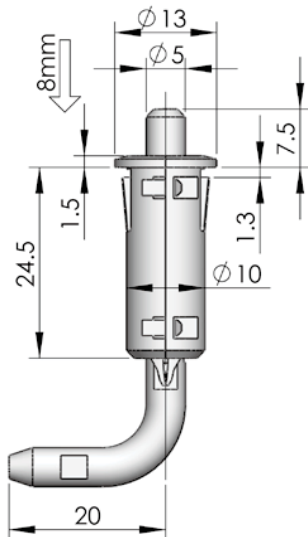

ERP	CL225N00001
-----	-------------

CL225-5



Main material and finish: Black PA housing, white zinc-plated ZDC latch, stainless steel spring

Application: Telescopic 8mm

Accessories

Electronic lock

Handle lock

Cylinder lock

Plane lock

Rod control lock

Panel lock

Toggle and hook

Handles

Door stop

Hinge

Seal gasket

- Accessories
- Electronic lock
- Handle lock
- Cylinder lock
- Plane lock
- Rod control lock
- Panel lock
- Toggle and hook
- Handles
- Door stop
- Hinge
- Seal gasket

CL225-7



CL225-7-Y

Main material and finish: White zinc plated steel hinge leaf

Performance parameter:
 Maximum static load
 Radial load: 525N
 Axial load: 125N

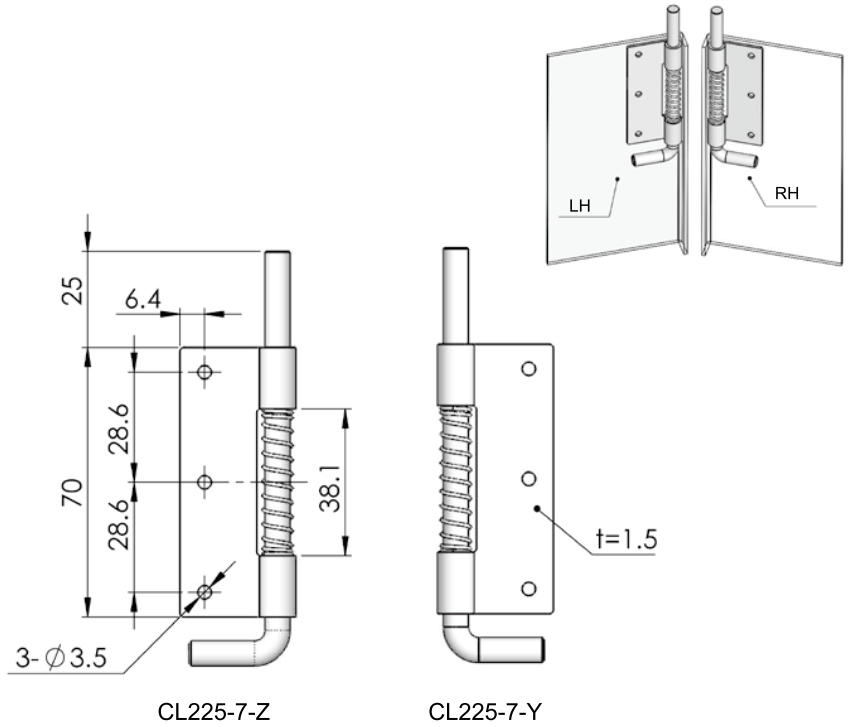

	CL225-7-Z LH	CL225-7-Y RH
ERP	CL225F3J001	CL225F3J002

CL226-4A



Main material and finish: Black powder coated ZDC hinge, nickel-plated steel pin
 Application: Opening degree 180°

Performance parameter:
 Maximum static load
 Radial load: 1120N
 Axial load: 1200N
 Embedded screw recommended
 tightening torque : 12N.m

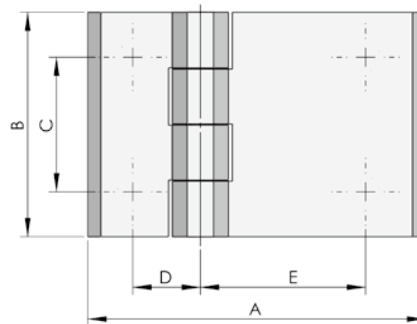
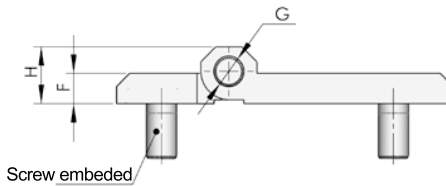

Model	ERP	Specification								Remark
		A	B	C	D	E	F	G	H	
CL226-4-1	CL226Z1A019	90	60	36	18	44	8	8	15	Ø8.4 Countersunk hole, ZDC
CL226-4A-1	CL226Z1A020	90	60	36	18	44	8	8	15	M8 Screw embedded, ZDC
CL226-4-2	CL226Z1A021	63	50	30	15	28	6	6	11.5	Ø6.3 Countersunk hole, stainless steel
CL226-4A-2	CL226Z1A022	63	50	30	15	28	6	6	11.5	M6 Screw embedded, ZDC

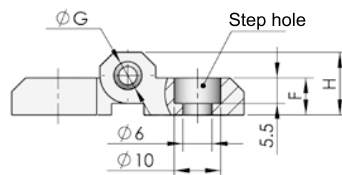
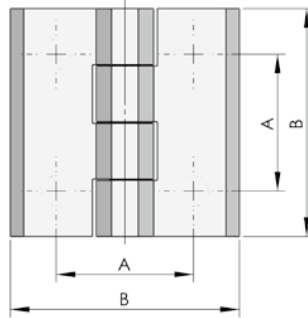
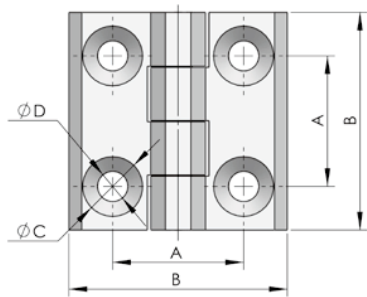
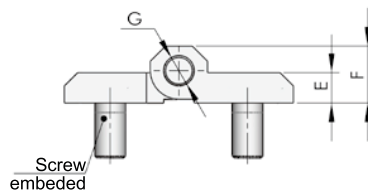
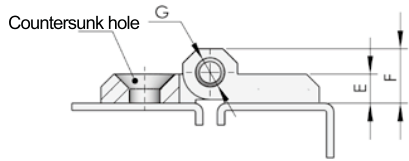

CL226



CL226-1



CL226-2



CL226-3



CL226-2A



Main material and finish: Black powder coated ZDC hinge, nickel-plated steel pin
Application: Opening angle 180°

Performance parameter:

Maximum static load

Model: CL226-1

Radial load: 1500N Axial load: 1800N

Model: CL226-2

Radial load: 1200N Axial load: 1300N

Model: CL226-3

Radial load: 1000N Axial load: 1200N

Model: CL226-2A

Radial load: 1200N Axial load: 1300N

Embedded screw recommended
tightening torque : 10N.m

Model	ERP	Specification							Remark
		A	B	C	D	E	F	G	
CL226-1	CL226Z1A001	36	60	16.5	8.4	8	15	8	Countersunk hole,ZDC
CL226-1A	CL226Z1A006	36	60	16.5	8.4	8	15	8	Screw embedded, ZDC
CL226-1B	CL226S9C001	36	60	16.5	8.4	8	15	8	Countersunk hole, stainless steel
CL226-2	CL226Z1A009	30	50	12.5	6.3	6	11.5	6	Countersunk hole,ZDC
CL226-2A	CL226Z1A010	30	50	Refer to detailed drawing		6	11.5	6	Screw embedded, ZDC
CL226-2C	CL226Z1A011	30	50	Refer to detailed drawing		6	11.5	6	Step hole,ZDC
CL226-2S	CL226N00001	30	50	12.5	6.3	6	11.5	6	Countersunk hole,PA
CL226-2B	CL226S4B001	30	50	12.5	6.3	6	11.5	6	Countersunk hole, stainless steel
CL226-3	CL226Z1A015	25	40	10.2	5.3	5	9	4	Countersunk hole,ZDC
CL226-3A	CL226Z1A017	25	40	10.2	5.3	5	9	4	Screw embedded, ZDC

Accessories

Electronic lock

Handle lock

Cylinder lock

Plane lock

Rod control lock

Panel lock

Toggle and hook

Handles

Door stop

Hinge

Seal gasket



- Accessories
- Electronic lock
- Handle lock
- Cylinder lock
- Plane lock
- Rod control lock
- Panel lock
- Toggle and hook
- Handles
- Door stop
- Hinge**
- Seal gasket

CL226-5A



Main material and finish: Black powder coated ZDC hinge, nickel-plated steel pin
 Application: Opening angle 180°

Performance parameter:
 Maximum static load
 Radial load: 1120N
 Axial load: 1200N
 Embedded screw recommended
 tightening torque : 12N.m

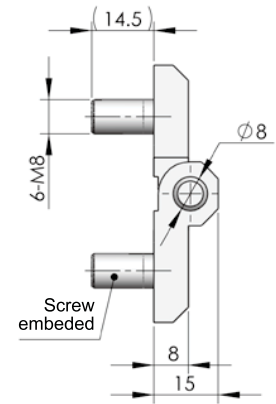
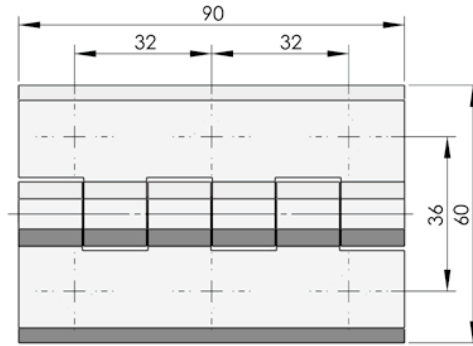

	CL226-5A-Z LH	CL226-5A-Y RH
ERP	CL226Z1A024	CL226Z1A025

CL226-6A



Main material and finish: Black powder coated ZDC hinge, nickel-plated steel pin
 Application: Opening angle 180°

Performance parameter:
 Maximum static load
 Radial load: 520N
 Axial load: 210N
 Embedded screw recommended
 tightening torque : 9N.m

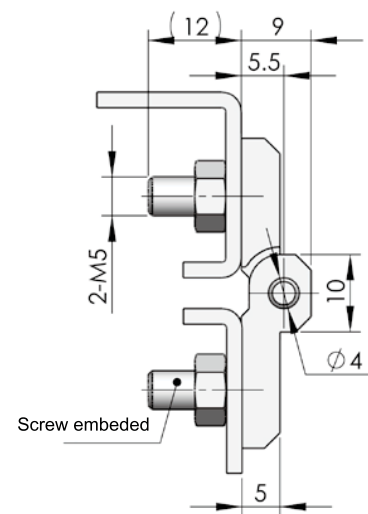
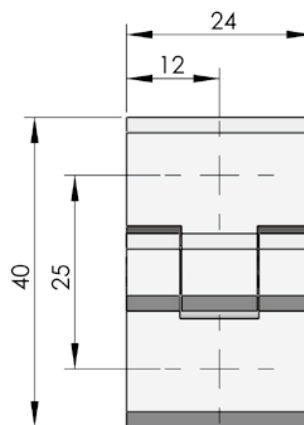

ERP	CL226Z1A026
-----	-------------

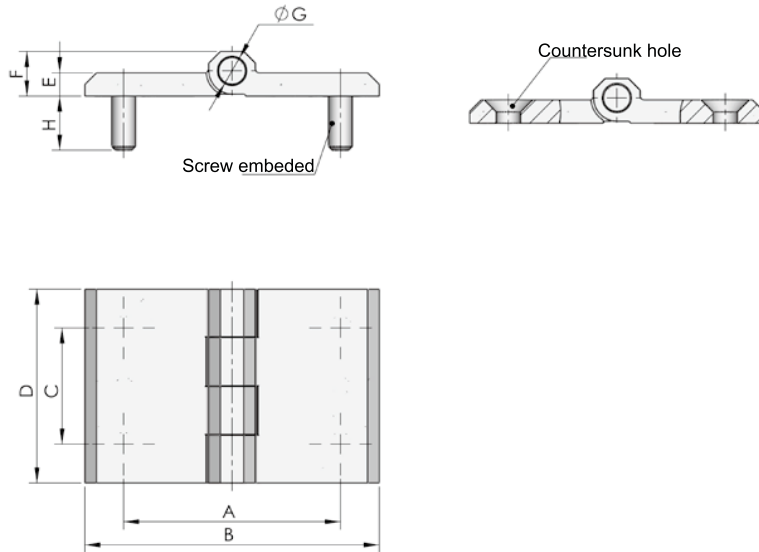

Model	ERP	Specification								Remark
		A	B	C	D	E	F	G	H	
CL226-7-1	CL226Z1A028	56	76	30	50	6	11.5	6		Ø6.3 Countersunk hole, ZDC
CL226-7A-1	CL226Z1A029	56	76	30	50	6	11.5	6	12.5	M6 Screw embedded, ZDC
CL226-7-2	CL226Z1A034	88	120	36	60	8	15	8		Ø6.8 Countersunk hole, ZDC
CL226-7A-2	CL226Z1A030	88	120	36	60	8	15	8	16.5	M8 Screw embedded, ZDC

CL226-7
CL226-7A



Main material and finish: Black powder coated ZDC hinge, nickel-plated steel pin
Application: Opening angle 180°

Performance parameter:
Maximum static load
Radial load: 1120N
Axial load: 1200N
Embedded screw recommended
tightening torque : 12N.m

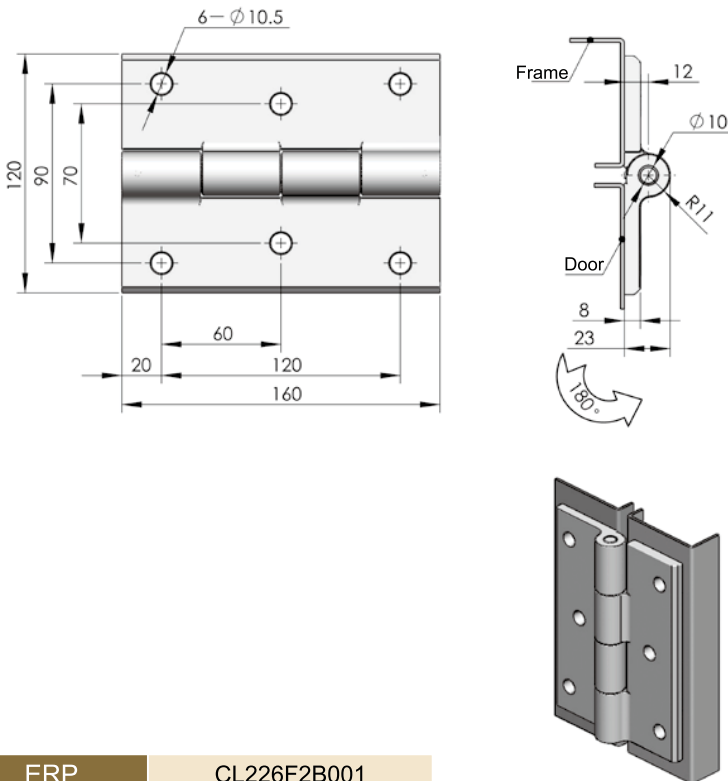

CL226-8



Main material and finish: Nanometer painted steel hinge leaf, shaft
Application: Opening angle 180°

Performance parameter:
Maximum static load
Radial load: 3000N
Axial load: 3000N

ERP CL226F2B001

- Accessories
- Electronic lock
- Handle lock
- Cylinder lock
- Plane lock
- Rod control lock
- Panel lock
- Toggle and hook
- Handles
- Door stop
- Hinge
- Seal gasket

Accessories

Electronic lock

Handle lock

Cylinder lock

Plane lock

Rod control lock

Panel lock

Toggle and hook

Handles

Door stop

Hinge

Seal gasket

CL229-2A
CL229-2B



Main material and finish: Electrolysis stainless steel hinge
Application: Opening angle 90°

Performance parameter:
Maximum static load
Radial load: 425N
Axial load: 225N

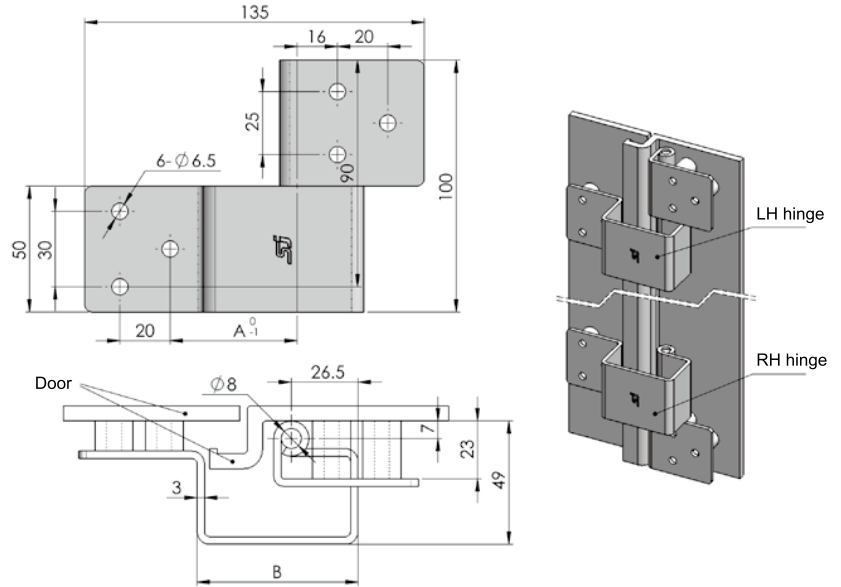

Model	ERP	Speci fication	
		A	B
CL229-2A-Z	CL229S9C001	50.5	64
CL229-2A-Y	CL229S9C003	50.5	64
CL229-2B-Z	CL229S9C002	56.5	68
CL229-2B-Y	CL229S9C004	56.5	68

CL230-3



Main material and finish: Black powder coated ZDC hinge, nickel-plated steel pin
Application: Opening angle 180°

Performance parameter:
Maximum static load
Radial load: 940N
Axial load: 720N

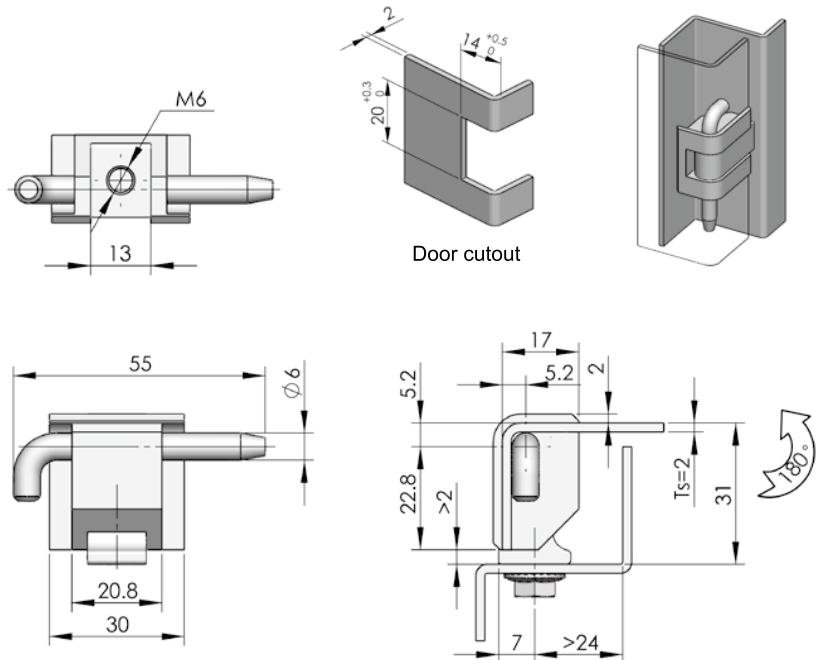

Remark: Nylon pin optional, details refer to CL230

ERP

CL230Z1A026

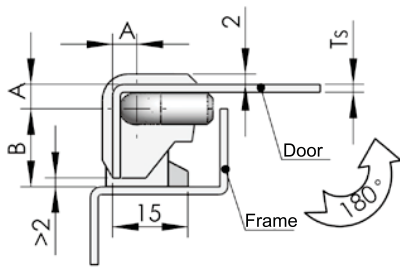
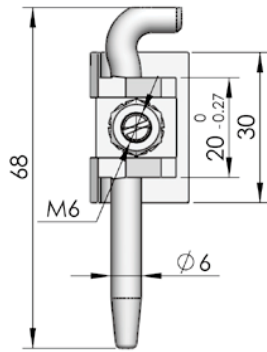
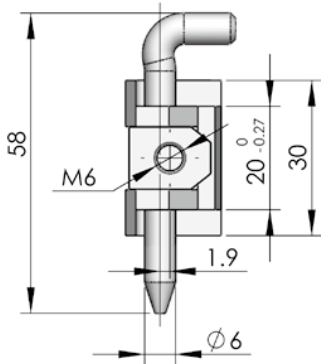

CL230

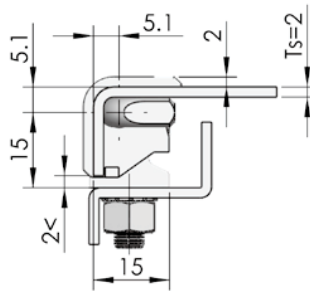

CL230-4

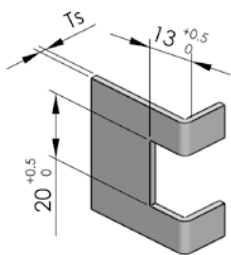

Door cutout

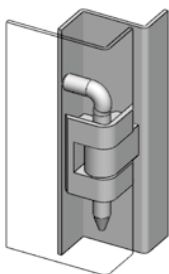

ERP CL230S4B001

Nylon pin (Optional)

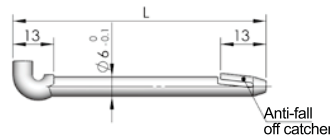

Part No.	L
PN001	57
PN002	78

CL230



Main material and finish: Black powder coated ZDC hinge, nickel-plated steel pin
Application: Opening angle 180°

Performance parameter:
Maximum static load
Model: CL230-1
Radial load: 940N Axial load: 720N

CL230-4



Main material and finish: Wire-drawing polishing stainless steel hinge
Application: Opening angle 180°

Performance parameter:
Maximum static load
Radial load: 900N
Axial load: 700N

Model	ERP	Specification		
		Ts	A	B
CL230-1	CL230Z1A001	Ts=1.5	4.6	15
CL230-2	CL230Z1A013	Ts=2	5.1	15
CL230-1A	CL230Z1A004	Ts=1.5	4.6	17
CL230-2A	CL230Z1A016	Ts=2	5.1	17
CL230-1B	CL230Z1A007	Ts=1.5	4.6	19
CL230-2B	CL230Z1A019	Ts=2	5.1	19

Accessories

Electronic lock

Handle lock

Cylinder lock

Plane lock

Rod control lock

Panel lock

Toggle and hook

Handles

Door stop

Hinge

Seal gasket

- Accessories
- Electronic lock
- Handle lock
- Cylinder lock
- Plane lock
- Rod control lock
- Panel lock
- Toggle and hook
- Handles
- Door stop
- Hinge
- Seal gasket

CL230-3-1D



Main material and finish: Bright chrome plated ZDC hinge and steel shaft
Application: Opening angle 180°

Performance parameter:
Maximum static load
Radial load: 940N
Axial load: 720N

CL232

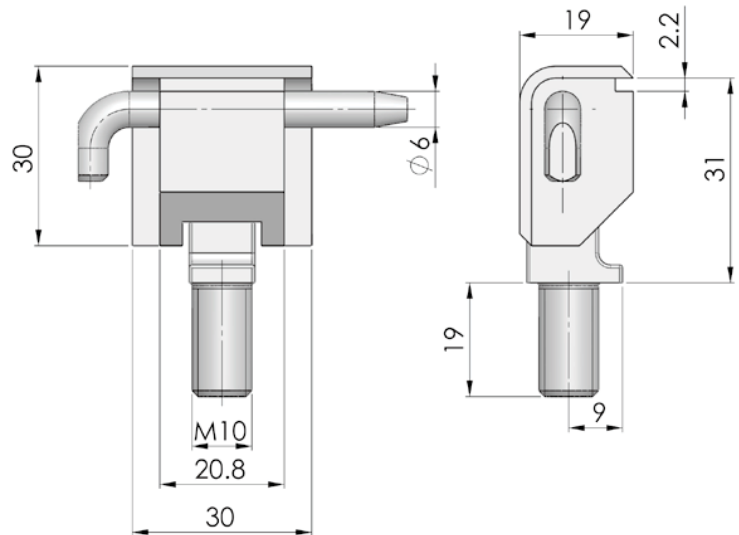

ERP

CL230Z3A019

CL231



Main material and finish: Bright chrome plated ZDC hinge, nickel-plated steel pin, brass gasket
Application: Opening angle 180°

Performance parameter:
Maximum static load
Model: CL231-1
Radial load: 330N Axial load: 760N
Model: CL231-2
Radial load: 575N Axial load: 125N

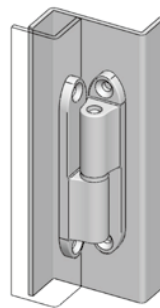
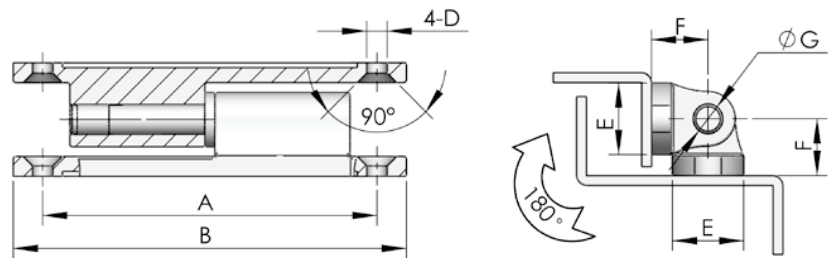

Model	ERP	Specification						
		A	B	C	D	E	F	G
CL231-1	CL231Z3A001	68	80	$\phi 8$	$\phi 4.2$	14.5	11.5	$\phi 6$
CL231-2	CL231Z3A004	48	60	$\phi 9.4$	$\phi 4.5$	13	9.5	$\phi 5$

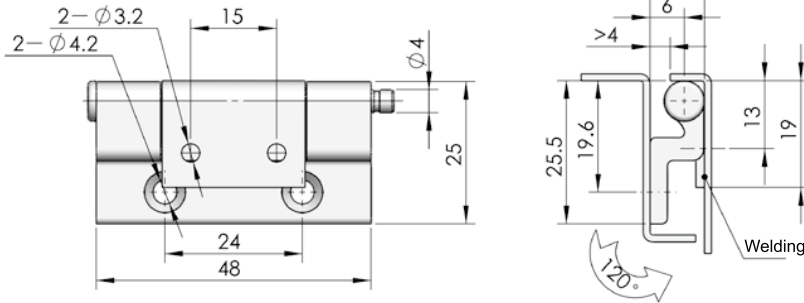

ERP

CL232Z3H001

CL232



Main material and finish: Sand-spraying and bright chrome-plated ZDC female hinge, white zinc-plated steel male hinge, nickel plated steel pin
Application: Opening angle 120°

Performance parameter:
Maximum static load
Radial load: 420N
Axial load: 1050N

Accessories

Electronic lock

Handle lock

Cylinder lock

Plane lock

Rod control lock

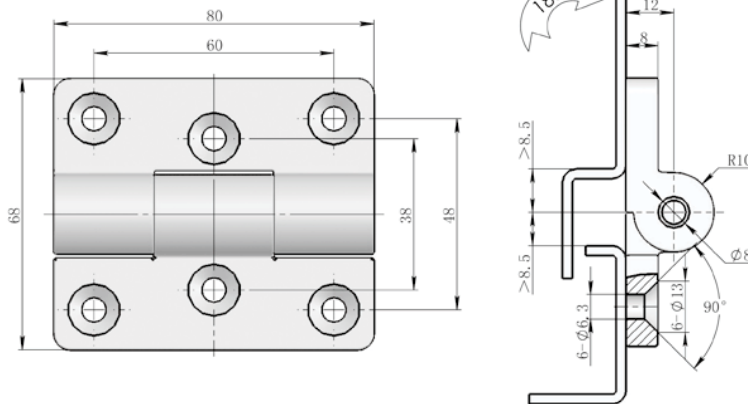

ERP

CL233S9C001

CL233



Main material and finish: Electrolysis or polishing stainless steel hinge
Application: Opening angle 180°

Performance parameter:
Maximum static load
Radial load: 3000N
Axial load: 3000N

Panel lock

Toggle and hook

Handles

Door stop



Hinge

Seal gasket

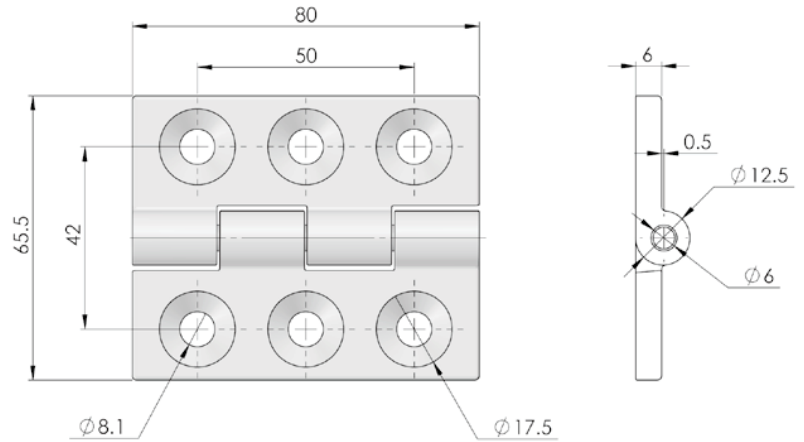
Accessories	 <p>CL233-2</p> <p>Main material and finish: Black powder coated ZDC hinge, steel pin Application: Opening angle 120°</p> <p>Performance parameter: Maximum static load Radial load: 1000N Axial load: 1200N</p>
Electronic lock	
Handle lock	
Cylinder lock	
Plane lock	
Rod control lock	



ERP	CL233Z1A001
-----	-------------

Panel lock	 <p>CL234</p>  <p>Main material and finish: Black powder coated ZDC hinge, nickel-plated steel pin Application: Opening angle 180°</p> <p>Performance parameter: Maximum static load Radial load: 1150N Axial load: 700N</p>
Toggle and hook	
Handles	
Door stop	
Hinge	
Seal gasket	

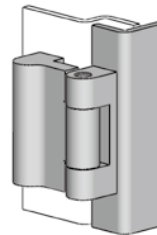
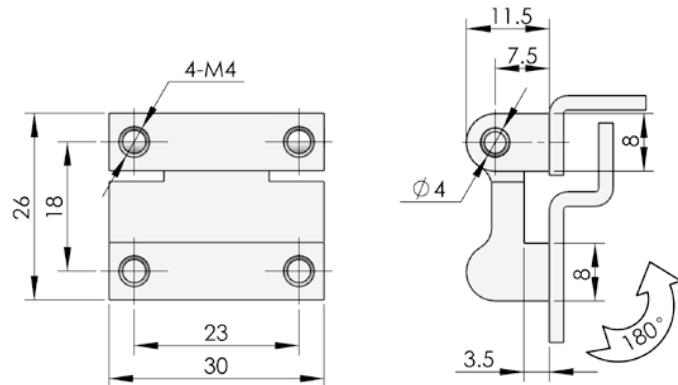

	Black powder coated	Nanometer painted
ERP	CL234Z1A001	CL234Z2B001

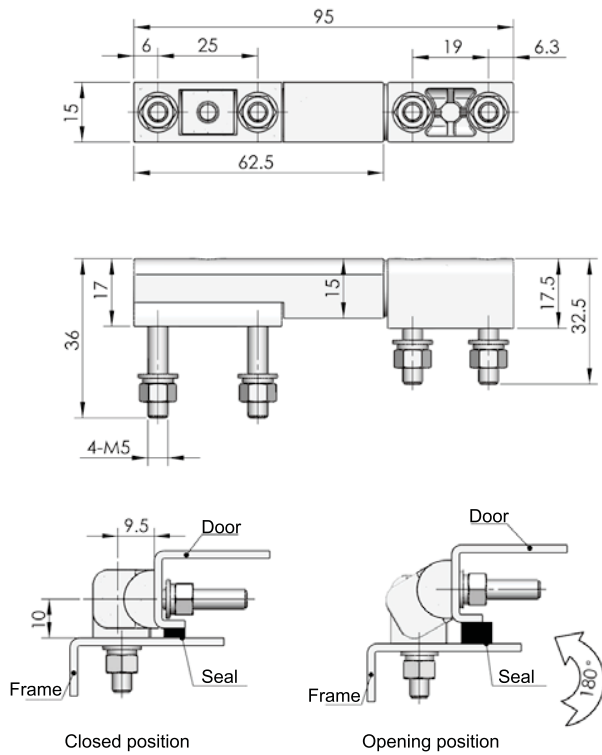

ERP CL235Z1B001

CL235



Main material and finish: Pocked black powder coated ZDC hinge, stainless steel screw

Application: Opening angle 180°

Performance parameter:

Maximum static load
Radial load: 165N
Axial load: 980N

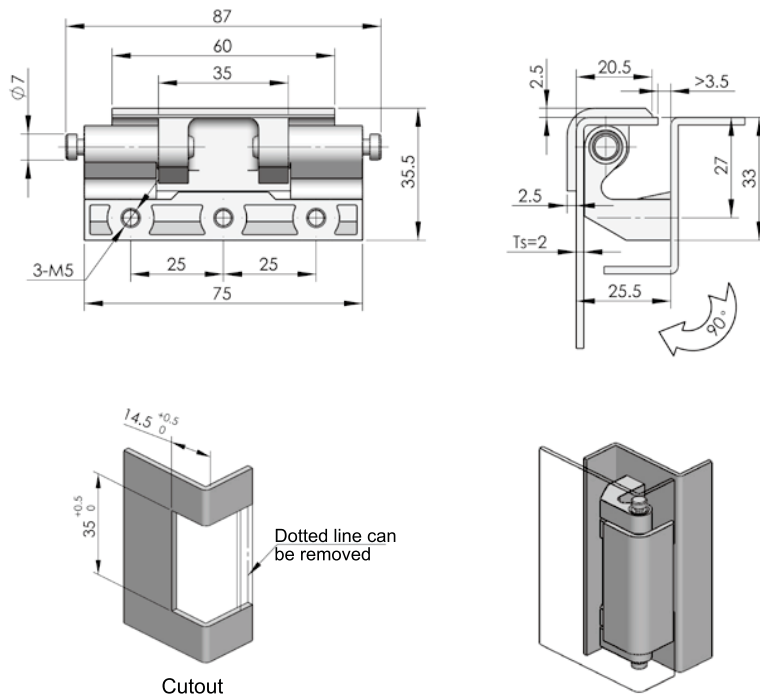

ERP	Black painted	Nanometer painted
ERP	CL236Z2A001	CL236Z2B001

CL236



Main material and finish: Black painted ZDC hinge, white zinc-plated steel pin

Application: Opening angle 180°

Performance parameter:

Maximum static load
Radial load: 1250N
Axial load: 600N

Accessories

Electronic lock

Handle lock

Cylinder lock

Plane lock

Rod control lock

Panel lock

Toggle and hook

Handles

Door stop

Hinge

Seal gasket

Accessories
Electronic lock
Handle lock
Cylinder lock
Plane lock
Rod control lock
Panel lock
Toggle and hook
Handles
Door stop
Hinge
Seal gasket

CL237



Main material and finish: Sand-spraying and nickel-plated ZDC female hinge, white zinc-plated steel male hinge, nickel plated steel pin
Application: Opening angle 90°

Performance parameter:
Maximum static load
Radial load: 1295N
Axial load: 290N

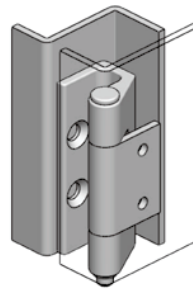
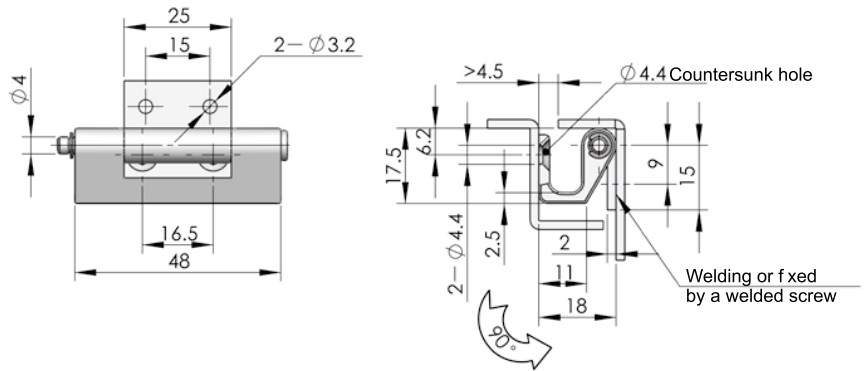

	Sand-spraying and bright chrome-plated	Sand-spraying and nickel-plated
ERP	CL237Z3H001	CL237Z3I001

CL237-2



Main material and finish: Griège painted (high salt mist resistant) female hinge, electrolysis male hinge and 316 stainless steel shaft
Application: Maximum opening angle 100°
Remark: Female hinge fixed with M4 screw (not provide), male hinge fixed with riveting or welding of cabinet door

Performance parameter:
Maximum static load
Radial load: 750N
Axial load: 365N

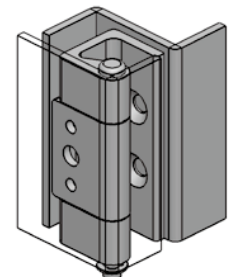
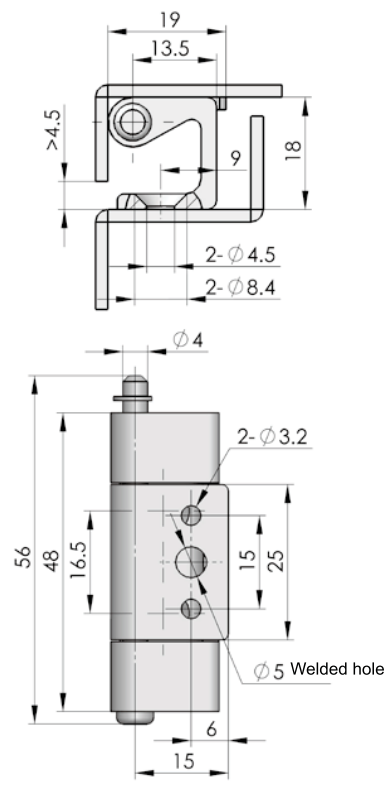

ERP	CL237S2G001
-----	-------------

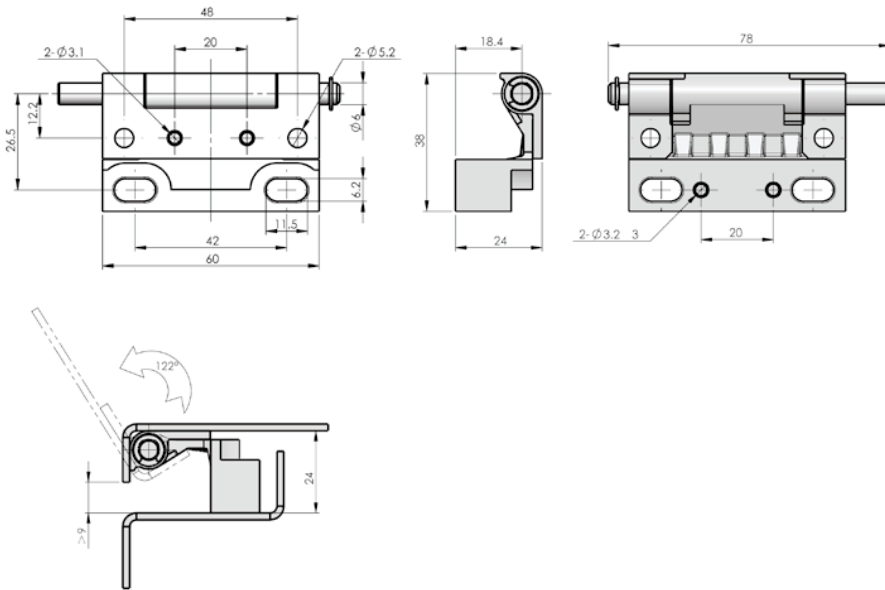

ERP CL237Z00001

CL237-3



Main material and finish: ZDC hinge and stainless steel shaft

Application: Opening angle 122°

Performance parameter:

Maximum static load

Radial load: 560N

Axial load: 840N

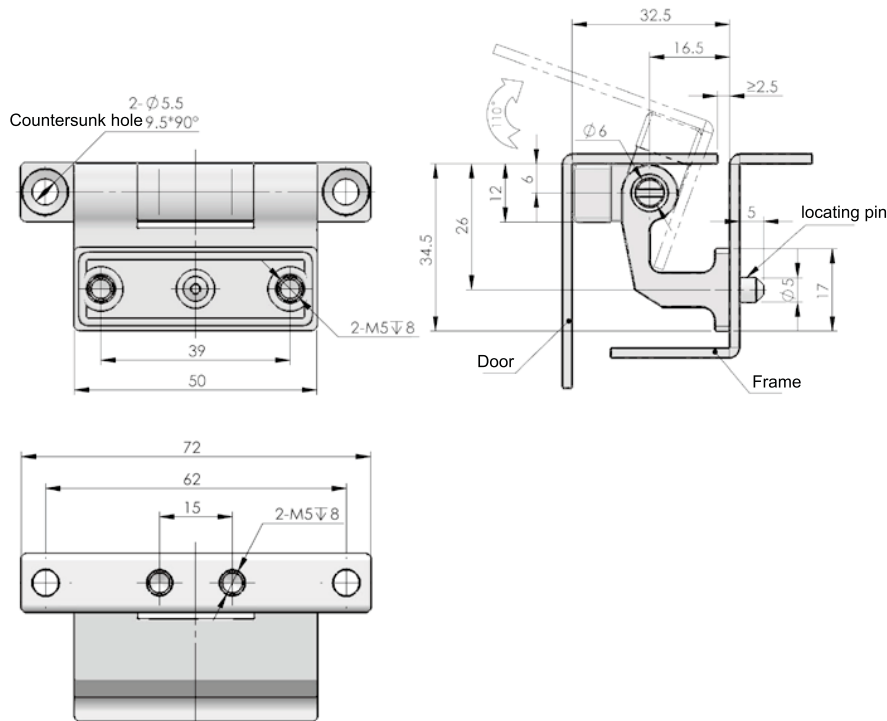

ERP CL237Z1A001

CL237-4



Main material and finish: Black powder coated ZDC hinge leaf, stainless steel pin and silicone washer

Application: Opening angle 110°

Performance parameter:

Maximum static load

Radial load: 1180N

Axial load: 1540N

Accessories

Electronic lock

Handle lock

Cylinder lock

Plane lock

Rod control lock

Panel lock

Toggle and hook

Handles

Door stop

Hinge

Seal gasket

Accessories	<p>CL238</p> <p>CL238-1</p>
Electronic lock	
Handle lock	
Cylinder lock	<p>CL238-2</p>
Plane lock	
Rod control lock	<p>CL238-3</p>
Panel lock	
Toggle and hook	<p>Main material and finish: Electrolysis stainless steel hinge Application: Opening angle 180°</p> <p>Performance parameter: Maximum static load Radial load: 520N Axial load: 600N</p>
Handles	
Door stop	
Hinge	
Seal gasket	

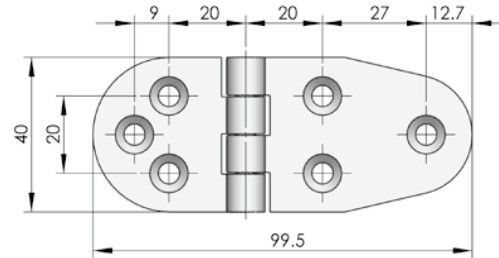
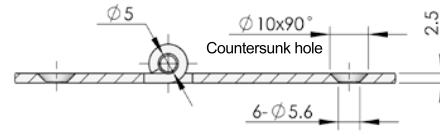

ERP CL238S9C001

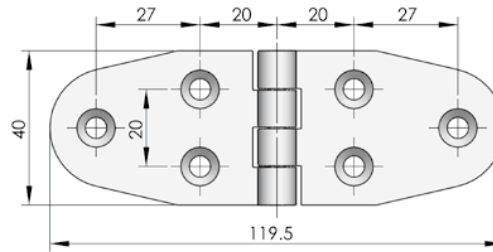

ERP CL238S9C002

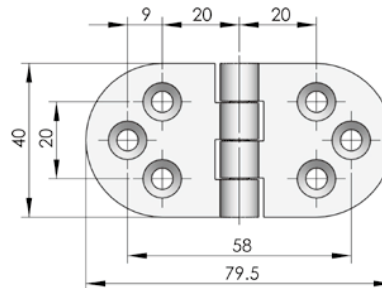

ERP CL238S9C003

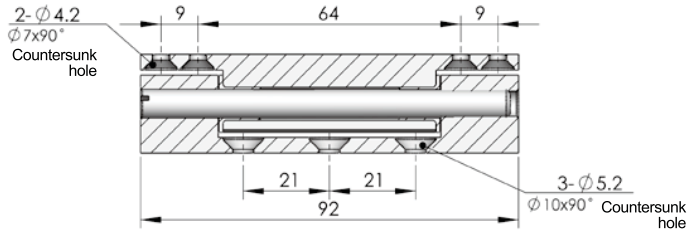

CL240-1

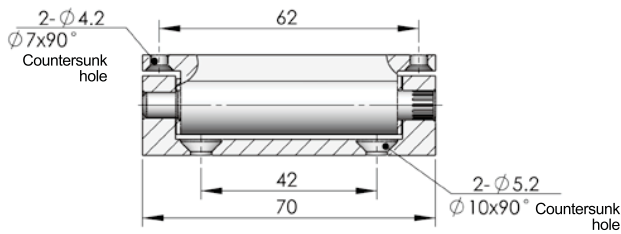
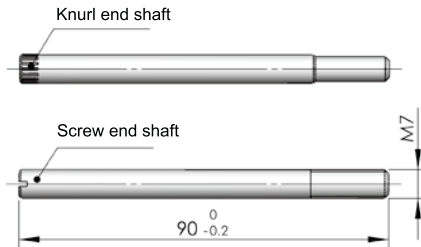

CL240-2

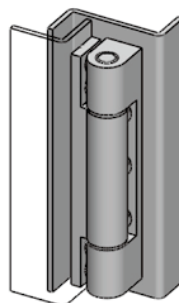
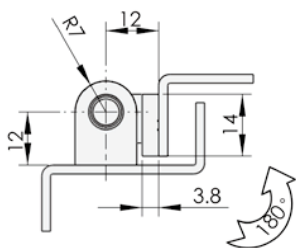
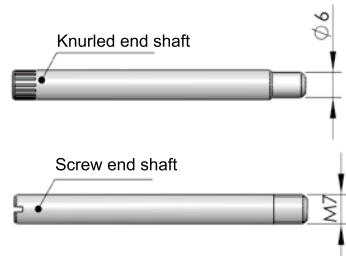

Model	ERP	Specification
CL240-1	CL240A9A001	With knurl end shaft
CL240-1D	CL240A9A002	With screw end shaft
CL240-2	CL240A9A003	With knurl end shaft
CL240-2D	CL240A9A004	With screw end shaft

CL240-1
CL240-2



Main material and finish: Oxidation aluminum alloy hinge, stainless steel shaft, nickel-plated steel pin
Application: Opening angle 180°

Performance parameter:

Maximum static load
Radial load: 500N
Axial load: 600N

Accessories

Electronic lock

Handle lock

Cylinder lock

Plane lock

Rod control lock

Panel lock

Toggle and hook

Handles

Door stop

Hinge

Seal gasket

Accessories	<p>CL244</p> 
Electronic lock	
Handle lock	
Cylinder lock	
Plane lock	
Rod control lock	 <p>Main material and finish: White zinc plated steel hinge and pin Application: Opening angle 120°</p> <p>Performance parameter: Maximum static load Radial load: 270N Axial load: 305N</p>

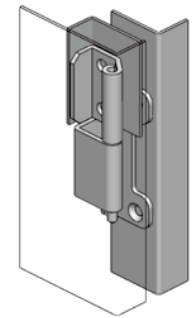
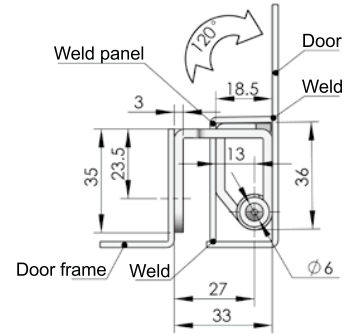
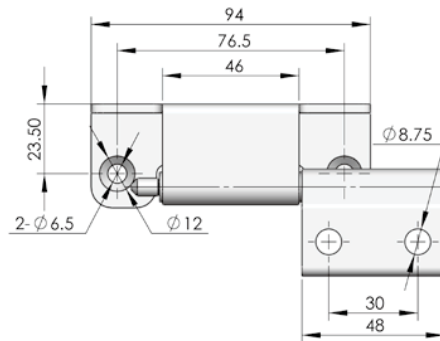

ERP CL244F3D001

Panel lock	<p>CL246</p> 
Toggle and hook	
Handles	
Door stop	
Hinge	
Seal gasket	 <p>Main material and finish: Sand-spraying and bright chrome-plated ZDC hinge, white zinc-plated steel pin Application: Opening angle 120°</p> <p>Performance parameter: Maximum static load Radial load: 1000N Axial load: 820N</p>

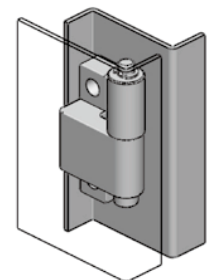
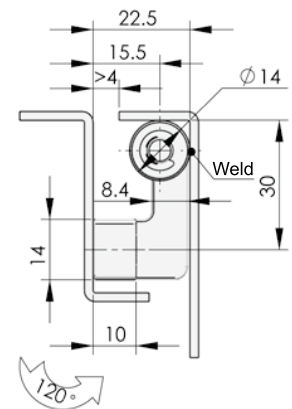
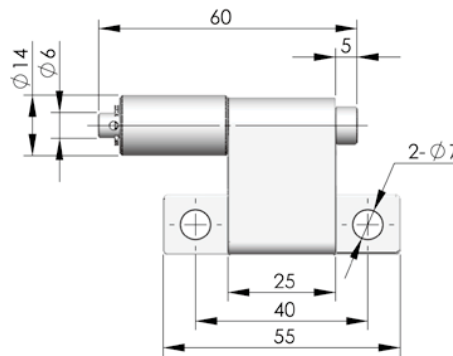

ERP CL246Z3H001

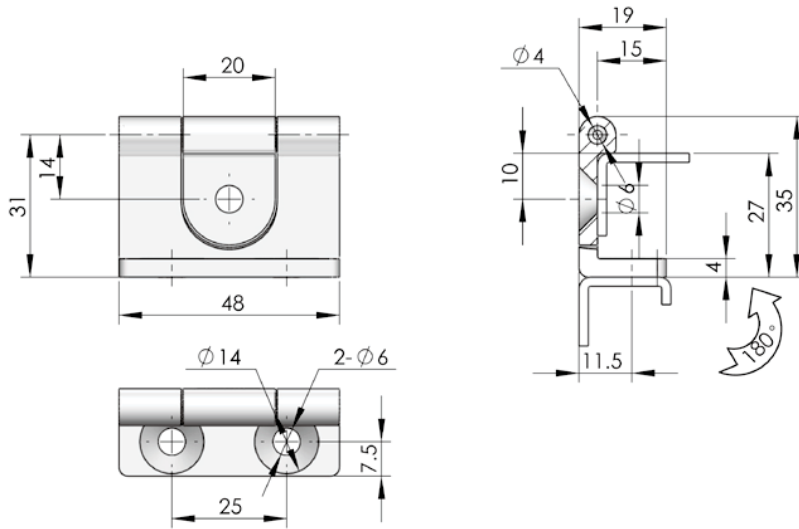

ERP

CL247Z1A001

CL247



Main material and finish: Black powder coated ZDC hinge, white zinc-plated steel pin
 Application: Opening angle 180°

Maximum static load
 Radial load: 780N
 Axial load: 490N

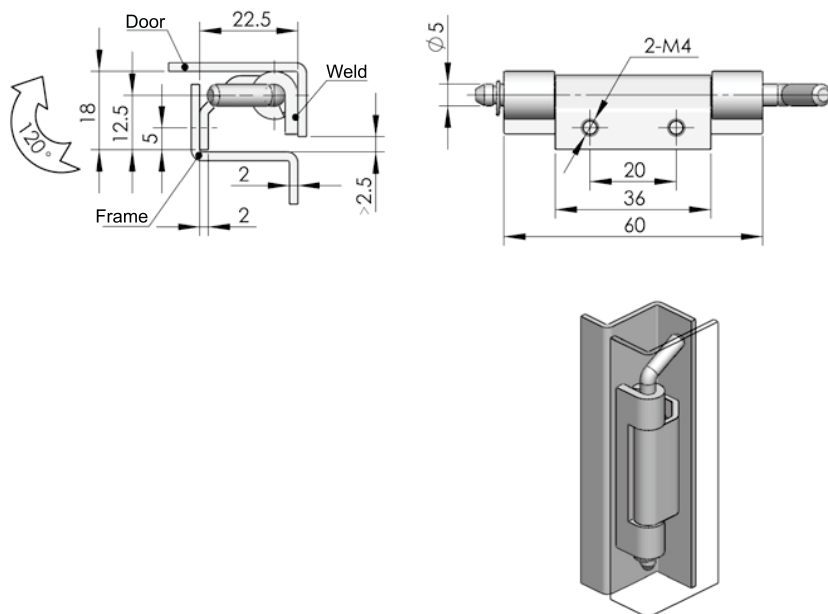

CL248



Main material and finish: White zinc plated steel and pin
 Application: Opening angle 120°

Performance parameter:
 Maximum static load
 Radial load: 280N
 Axial load: 250N

Model	ERP	Specification
CL248-1	CL248F3D001	White zinc plated steel
CL248-S	CL248S9C001	Electrolysis SUS316 hinge

Accessories

Electronic lock

Handle lock

Cylinder lock

Plane lock

Rod control lock

Panel lock

Toggle and hook

Handles

Door stop

Hinge

Seal gasket



Accessories

CL249



Electronic lock

Handle lock



Cylinder lock

Main material and finish: Steel or stainless steel hinge
Application: Opening angle 180°

Plane lock

Performance parameter:
Maximum static load
Radial load: 1200N
Axial load: 1300N

Rod control lock

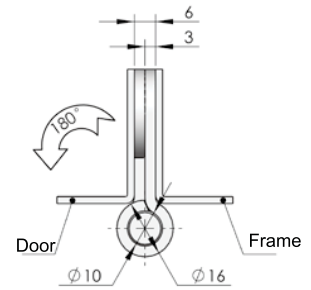
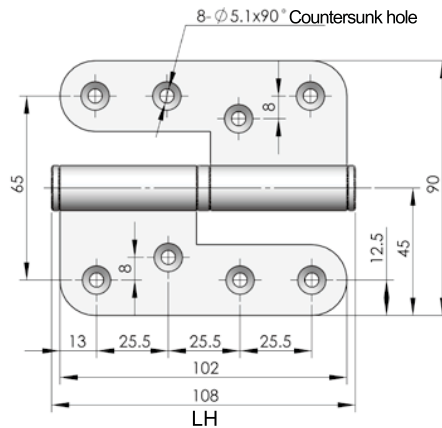

Specification	LH		RH	
	Model	ERP	Model	ERP
White zinc-plated steel hinge	CL249-1-Z	CL249F3D001	CL249-1-Y	CL249F3D002
Wiredrawing polishing stainless steel hinge	CL249-1B-Z	CL249S4B004	CL249-1B-Y	CL249S4B003

Panel lock

CL250-1
CL250-2



Toggle and hook

Handles



Door stop

Main material and finish: White zinc plated steel hinge and pin

Hinge

Performance parameter:
Maximum static load
Radial load: 310N
Axial load: 480N

Seal gasket

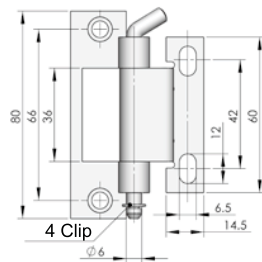
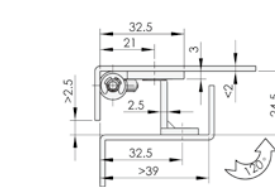
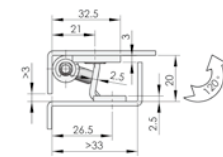

CL250-1

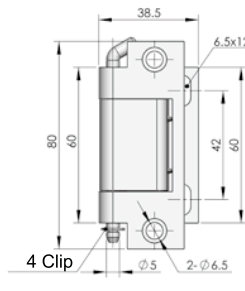

CL250-2

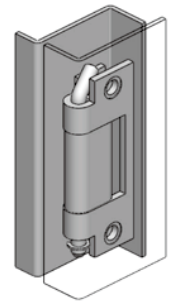

Model	ERP	Specification
CL250-1	CL250F3D001	White zinc plated steel
CL250-1B	CL250S00004	Grinding vibration polishing stainless steel
CL250-2	CL250F3D002	White zinc plated steel
CL250-2B	CL250S00003	Grinding vibration polishing stainless steel

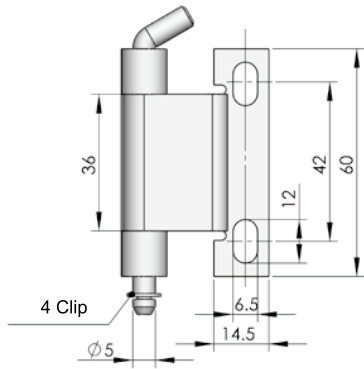
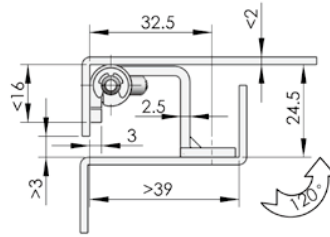
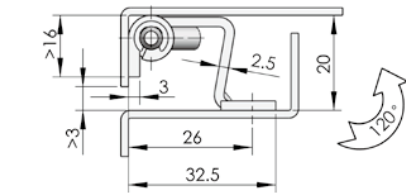

CL250-3

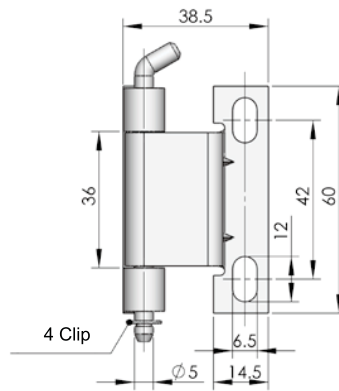

CL250-4

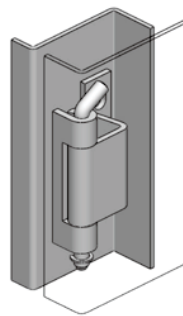

CL250-3
CL250-4



Main material and finish: White zinc plated steel hinge and pin
Application: Opening angle 120°

Performance parameter:
Maximum static load
Radial load: 350N
Axial load: 778N

Model	ERP	Specification
CL250-3	CL250F3D003	White zinc plated steel
CL250-3B	CL250S00007	Grinding vibration polishing stainless steel
CL250-4	CL250F3D004	White zinc plated steel
CL250-4B	CL250S00001	Grinding vibration polishing stainless steel

Accessories

Electronic lock

Handle lock

Cylinder lock

Plane lock

Rod control lock

Panel lock

Toggle and hook

Handleless

Door stop

Hinge

Seal gasket

Accessories

Electronic lock



Handle lock

Cylinder lock

Plane lock

Rod control lock

CL251

Main material and finish: Sand-spraying and bright chrome-plated ZDC hinge, stainless shaft pin and cover
 Application: Opening angle 180°

Performance parameter:
 Maximum static load
 Radial load: 1200N
 Axial load: 910N

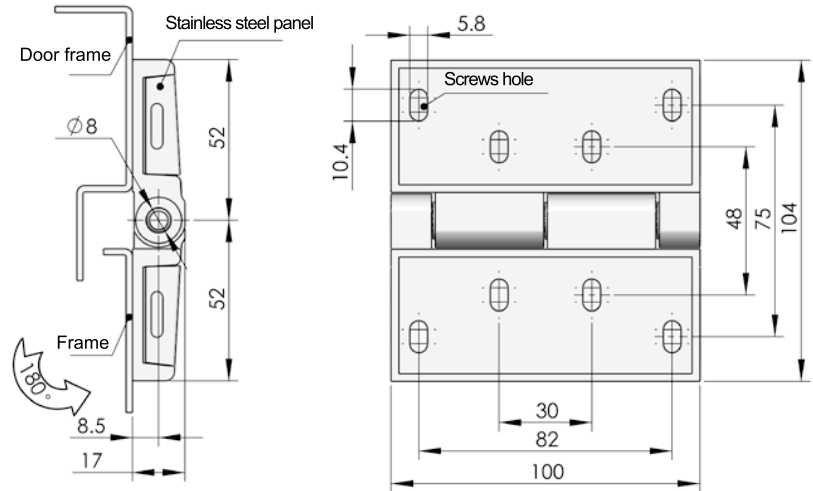

Remark: Disassembling panel when installing hinge by screw

ERP CL251Z3H001

Panel lock

Toggle and hook



Handles

Door stop

Hinge

Seal gasket

CL251-3

INOX
 AISI 3..

Main material and finish: Bright chrome plated ZDC exposed hinge Wire-drawing polishing
 Application: Opening angle 180°

Performance parameter:
 Maximum static load
 Radial load: 1000N
 Axial load: 1500N

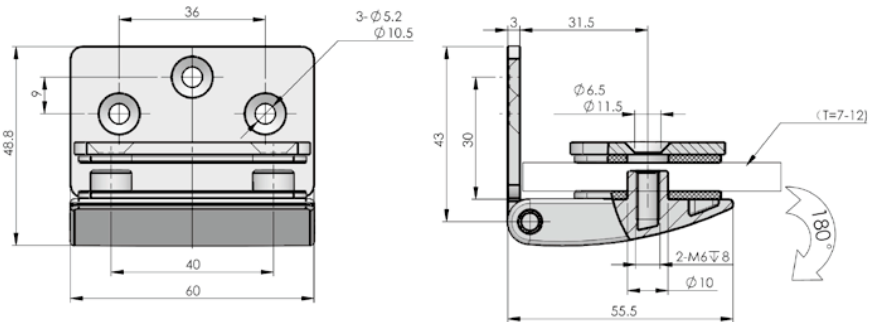

ERP CL251S4B001

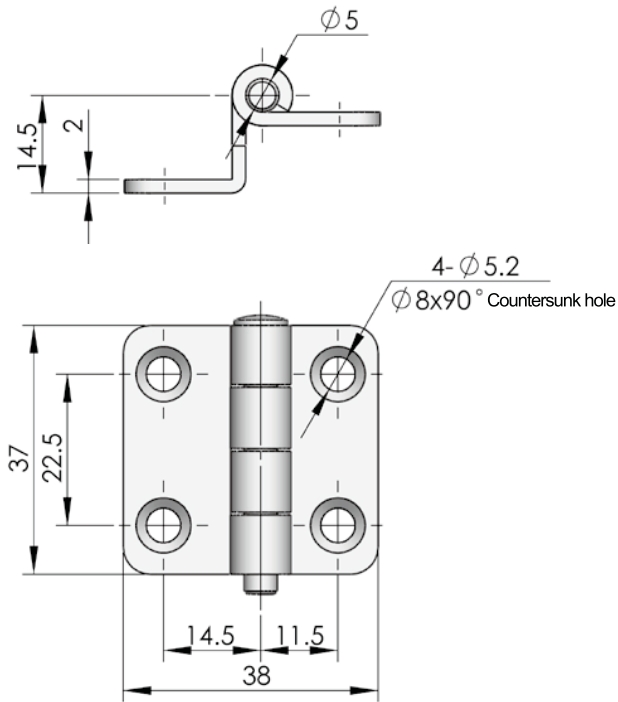

ERP CL252S00001

CL252



Main material and finish: Stainless steel hinge

Application: Opening angle 180°

Performance parameter:

Maximum static load

Radial load: 520N

Axial load: 800N

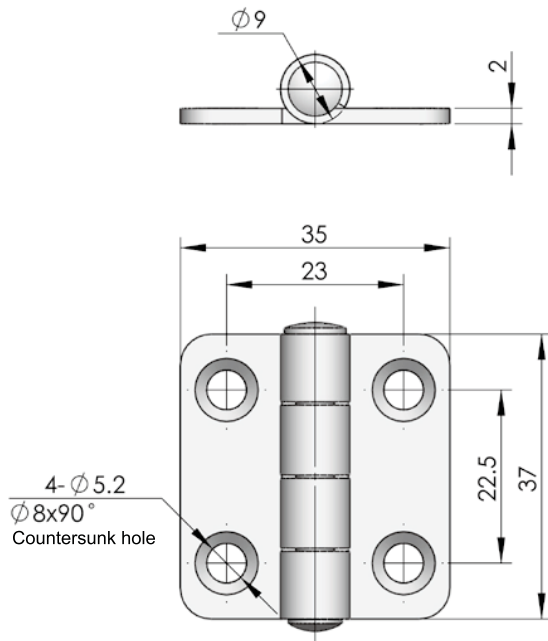

ERP CL253S4A001

CL253-1



Main material and finish: Mirror polishing stainless steel hinge

Application: Opening angle 180°

Performance parameter:

Maximum static load

Radial load: 745N

Axial load: 1090N

Accessories

Electronic lock

Handle lock

Cylinder lock

Plane lock

Rod control lock

Panel lock

Toggle and hook

Handles

Door stop

Hinge

Seal gasket

Accessories

Electronic lock

Handle lock

Cylinder lock

Plane lock

Rod control lock

CL253-2
CL253-3

CL253-2 CL253-3

Main material and finish: Mirror polishing stainless steel hinge
Application: Opening angle 180°

Performance parameter:
Maximum static load
Model: CL253-2
Radial load: 1000N Axial load: 1200N

Model: CL253-3
Radial load: 1500N Axial load: 1800N

CL253-2

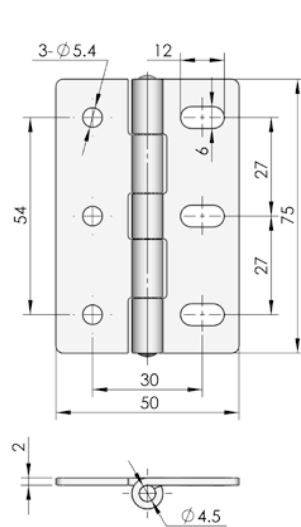

CL253-3

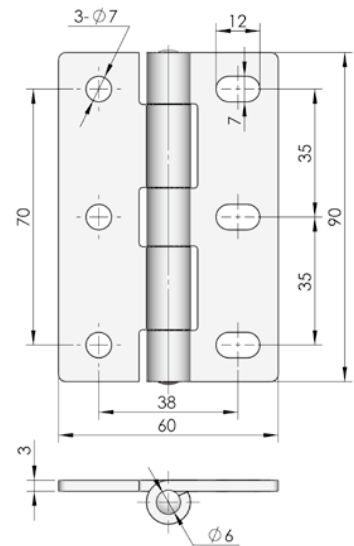

Model	ERP	Specification
CL253-2	CL253S4A002	Stainless steel
CL253-2-A	CL253F3D012	Carbon steel
CL253-3	CL253S4A003	Stainless steel

Panel lock

Toggle and hook

Handles

Door stop

Hinge

Seal gasket

CL253-4

INOX AISI 316

Main material and finish: Mirror polishing stainless steel hinge
Application: Opening angle 180°

Performance parameter:
Maximum static load
Radial load: 516N
Axial load: 665N

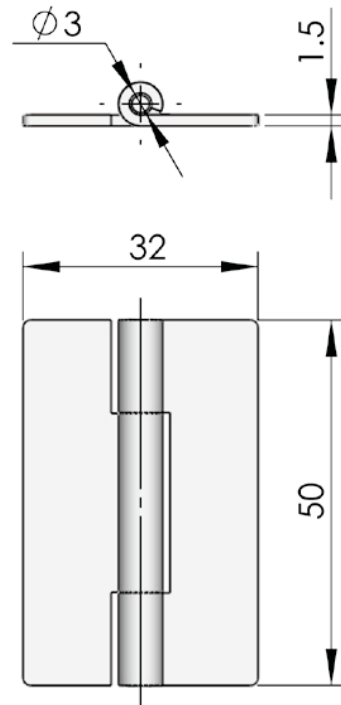

ERP	CL253S4A004
-----	-------------

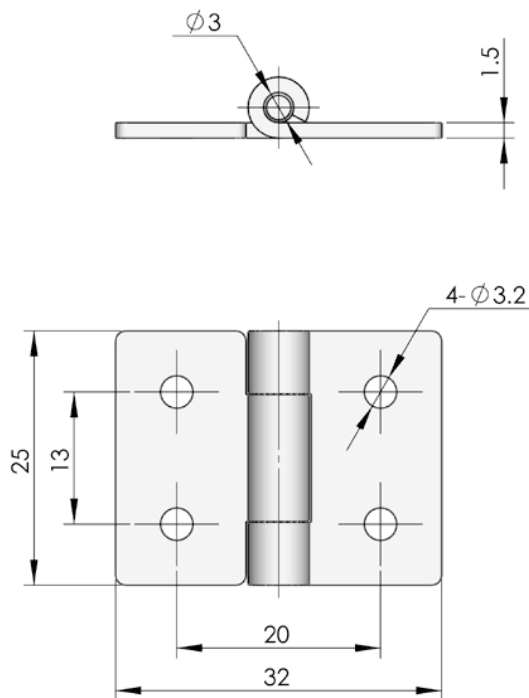

ERP

CL253S4A011

CL253-4A



INOX
AISI 3..

Main material and finish: Mirror polishing stainless steel hinge
Application: Opening angle 180°

Performance parameter:
Maximum static load
Radial load: 380N
Axial load: 810N

Accessories

Electronic lock

Handle lock

Cylinder lock

Plane lock

Rod control lock

Panel lock

Toggle and hook

Handles

Door stop

Hinge

Seal gasket

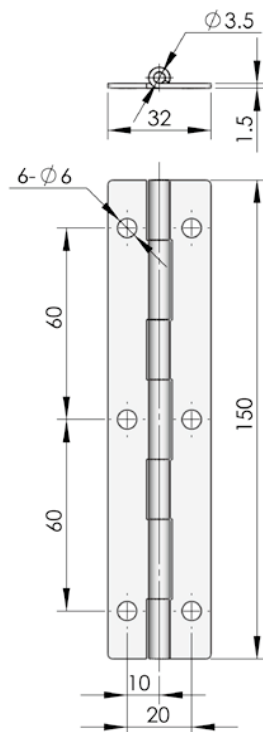

ERP

CL253F3D001

CL253-5



Main material and finish: White zinc-plated steel hinge
Application: Opening angle 180°

Performance parameter:
Maximum static load
Radial load: 840N
Axial load: 1380N

Accessories

Electronic lock



Handle lock

Cylinder lock

Plane lock

Rod control lock

CL253-6

Main material and finish: Mirror polishing stainless steel hinge Magnetic Shock
Application: Opening angle 180°

Performance parameter:
Maximum static load
Radial load: 550N
Axial load: 650N

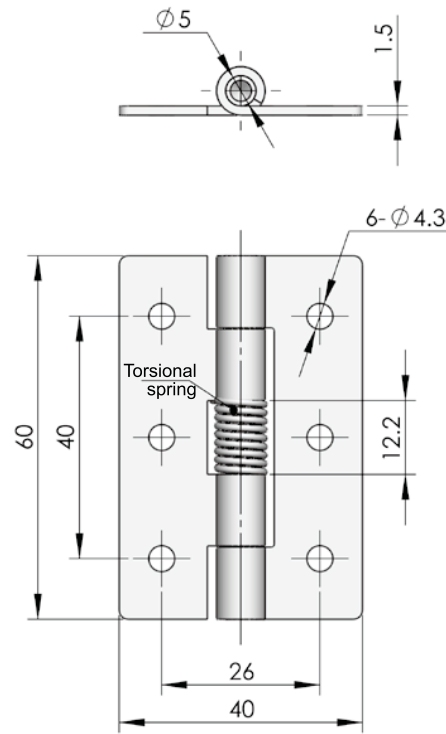

ERP

CL253S4A005

Panel lock

Toggle and hook



Handles

Door stop

Hinge

Seal gasket

CL253-7

Main material and finish: Mirror polishing stainless steel hinge
Application: Opening angle 180°

Performance parameter:
Maximum static load
Radial load: 590N
Axial load: 635N

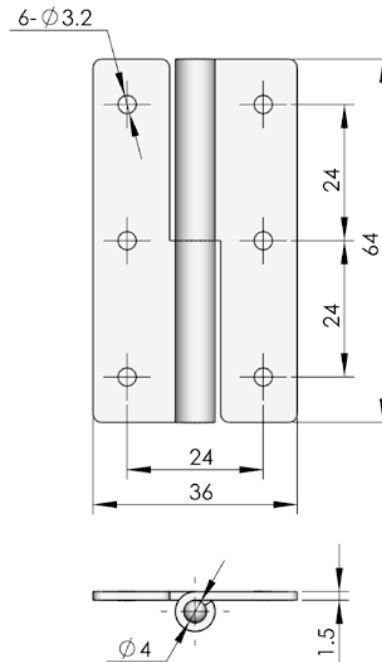

ERP

RH

CL253S4A006

LH

CL253S4A007

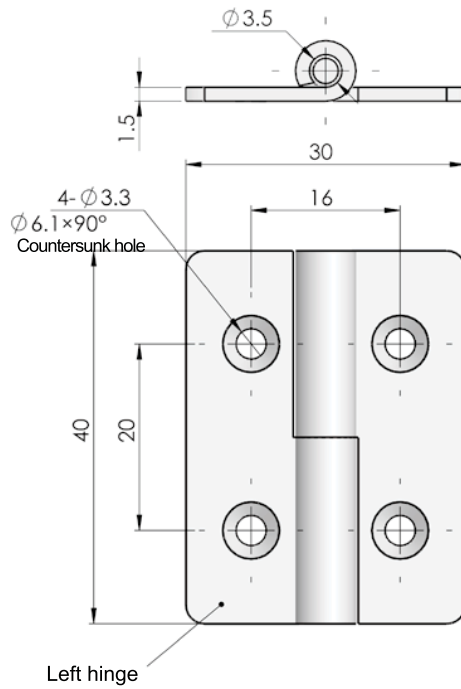

	CL253-9-Z RH	CL253-9-Y LH
ERP	CL253S4A008	CL253S4A009

CL253-9



Main material and finish: Stainless steel hinge leaf and shaft
 Application: Opening angle 180°

Performance parameter:
 Maximum static load
 Radial load: 305N
 Axial load: 470N

Accessories

Electronic lock

Handle lock

Cylinder lock

Plane lock

Rod control lock

Panel lock

Toggle and hook

Handles

Door stop

Hinge

Seal gasket

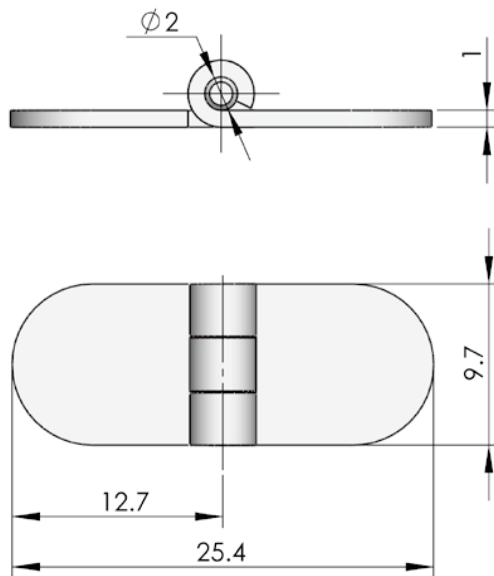

CL253-10



Main material and finish: Mirror stainless steel hinge and stainless steel shaft
 Application: Opening angle 180°

Performance parameter:
 Maximum static load
 Radial load: 76N
 Axial load: 161N

ERP	CL253S4A010
-----	-------------

Accessories

Electronic lock



Handle lock

Cylinder lock

Plane lock

Rod control lock

CL253-13

Main material and finish: Aluminum alloy hinge leaf, shaft
Application: Opening angle 180°

Performance parameter:
Maximum static load
Radial load: 180N
Axial load: 530N

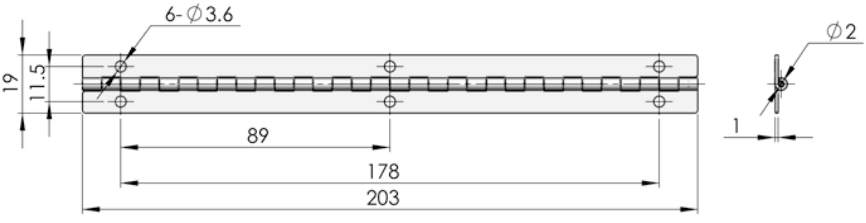

Technical drawing showing dimensions: 19, 11.5, 6- \varnothing 3.6, 89, 178, 203, \varnothing 2, 1.

ERP CL253A00001

Panel lock

Toggle and hook

Handles

Door stop

Hinge

Seal gasket

CL253-16



Main material and finish: Electrolysis SUS301 stainless steel hinge leaf, and SUS304 stainless steel shaft
Application: open angle 180°

Performance parameter:
Maximum static load
Radial load: 560N
Axial load: 830N

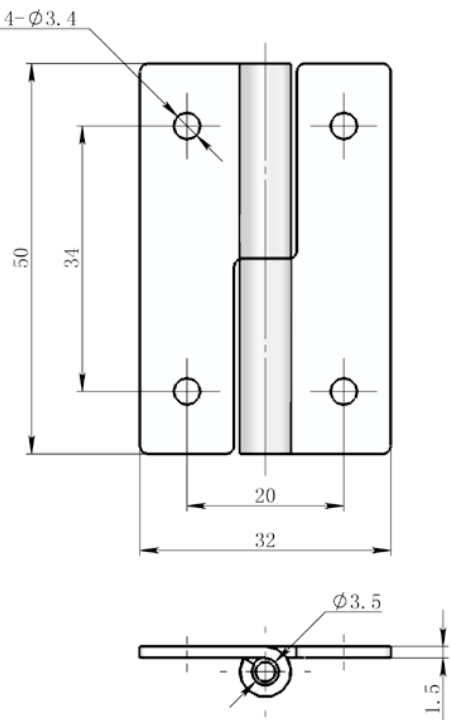

Technical drawing showing dimensions: 4- \varnothing 3.4, 50, 34, 20, 32, \varnothing 3.5, 1.5.

ERP CL253S9C004

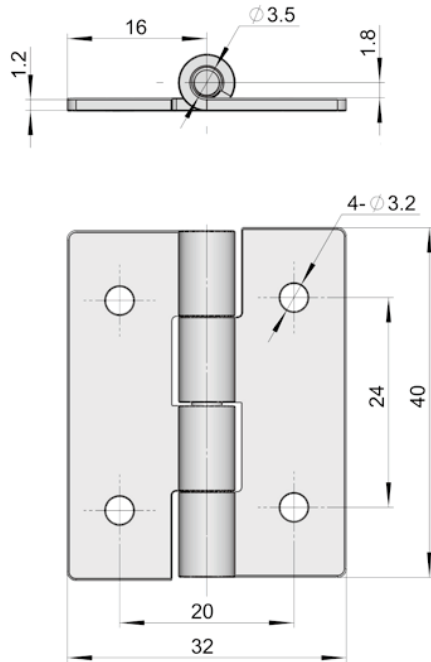

ERP CL253S4A037

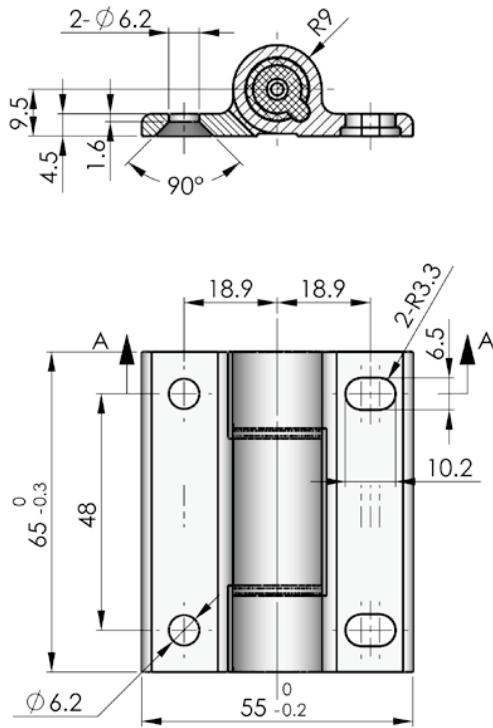

ERP CL253A9A001

CL253-20



Main material and finish: SUS304 mirror plastic board 304 stainless steel
Application: Opening angle 180°

Performance parameter:
Maximum static load
Radial load: 340N
Axial load: 600N

CL253-23



Main material and finish: Aluminum alloy hinge, POM shaft
Application: The hinge is damping hinge with bolt adjustable damping force

- Accessories
- Electronic lock
- Handle lock
- Cylinder lock
- Plane lock
- Rod control lock
- Panel lock
- Toggle and hook
- Handles
- Door stop
- Hinge
- Seal gasket

- Accessories
- Electronic lock
- Handle lock
- Cylinder lock
- Plane lock
- Rod control lock
- Panel lock
- Toggle and hook
- Handles
- Door stop
- Hinge
- Seal gasket

CL253-25



Main material and finish: Mirror polishing stainless steel SS304

Application: Opening angle 180°

Performance parameter:

Maximum static load

Radial load: 340N

Axial load: 600N

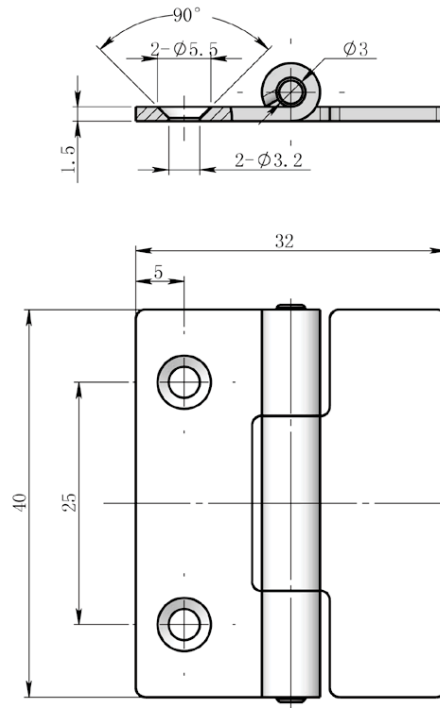

ERP CL253S4A049

CL253-26



Main material and finish: Mirror polishing stainless steel SS304

Application: Opening angle 180°

Performance parameter:

Maximum static load

Radial load: 780N

Axial load: 840N

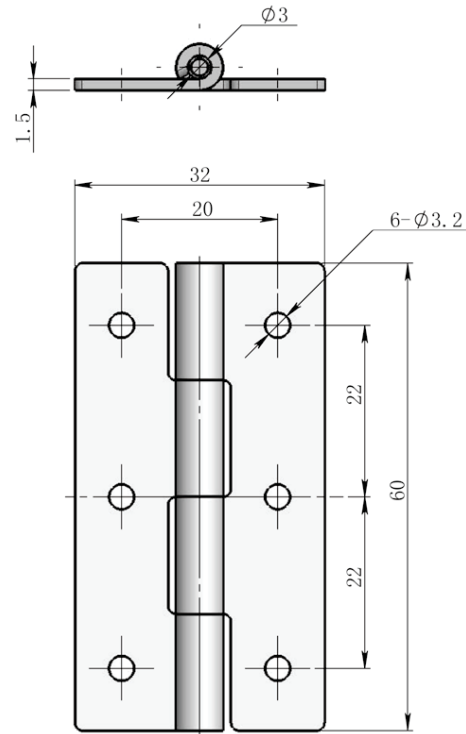

ERP CL253S4A040

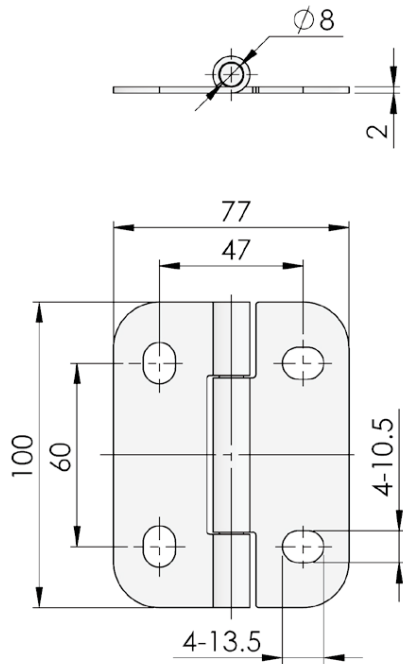

ERP

CL253F1A002

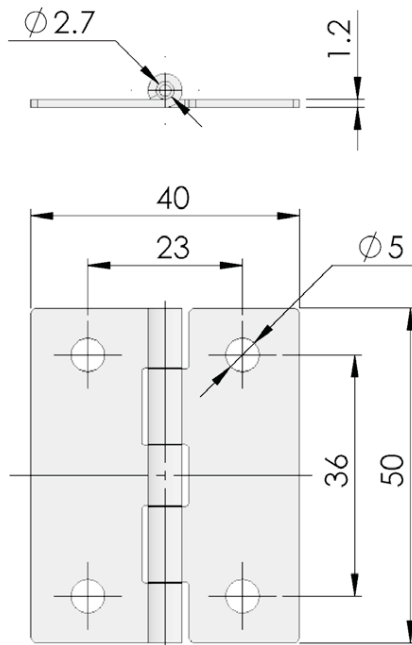

ERP

CL253F3D013

CL253-27



Main material and finish: Black powder coated carbon steel hinge
Application: Opening angle 180°

Performance parameter:
Maximum static load
Radial load: 500N
Axial load: 700N

CL253-28



Main material and finish: 3+ zinc plated carbon steel hinge
Application: Opening angle 180°

Performance parameter:
Maximum static load
Radial load: 990N
Axial load: 990N

Accessories

Electronic lock

Handle lock

Cylinder lock

Plane lock

Rod control lock

Panel lock

Toggle and hook

Handles

Door stop

Hinge

Seal gasket

Accessories
Electronic lock
Handle lock
Cylinder lock
Plane lock
Rod control lock
Panel lock
Toggle and hook
Handles
Door stop
Hinge
Seal gasket



CL253-30

Main material and finish: Mirror polishing stainless steel SS304
Application: Opening angle 180°

Performance parameter:
Maximum static load
Radial load: 310N
Axial load: 480N

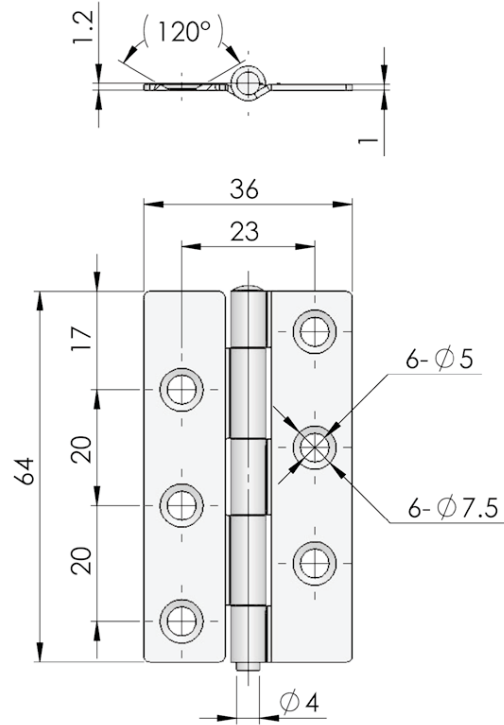

ERP CL253S4A054



CL253-31

Main material and finish: Mirror polishing stainless steel SS304
Application: Opening angle 180°

Performance parameter:
Maximum static load
Radial load: 650N
Axial load: 550N

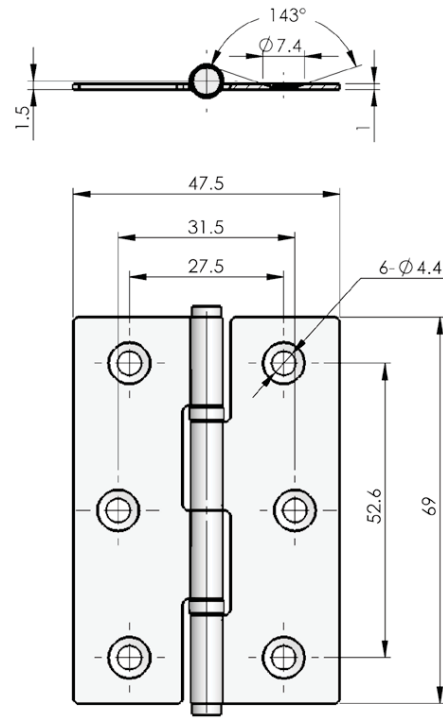

ERP CL253S00008

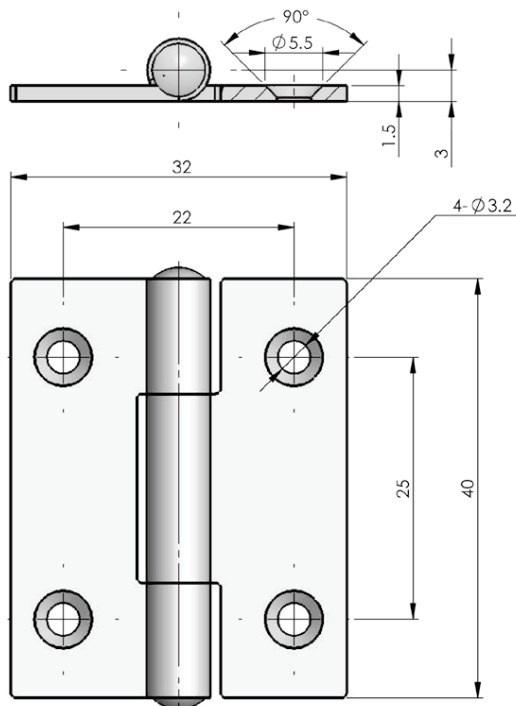

ERP

CL253S4A057

CL253-32-1



Main material and finish: Mirror polishing stainless steel SS304 exposed hinge
Application: Opening angle 180°

Performance parameter:
Maximum static load
Radial load: 610N
Axial load: 510N

Accessories

Electronic lock

Handle lock

Cylinder lock

Plane lock

Rod control lock

Panel lock

Toggle and hook

Handles

Door stop

Hinge

Seal gasket

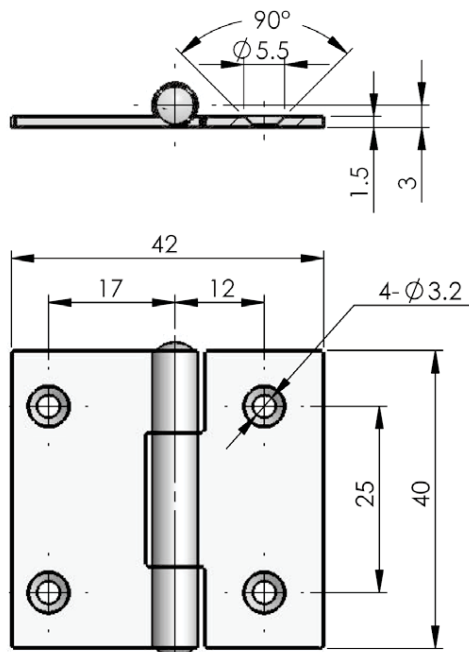

ERP

CL253S4A056

CL253-32-2



Main material and finish: Mirror polishing stainless steel SS304 exposed hinge
Application: Opening angle 180°

Performance parameter:
Maximum static load
Radial load: 450N
Axial load: 400N

Accessories

Electronic lock

Handle lock

Cylinder lock

Plane lock

Rod control lock

Panel lock

Toggle and hook

Handles

Door stop

Hinge

Seal gasket

CL255



Main material and finish: Black powder coated hinge, nickel plated steel pin
 Application: Opening angle 180°

Performance parameter:
 Maximum static load
 Model: CL255-1/2/3
 Radial load: 935N Axial load: 915N

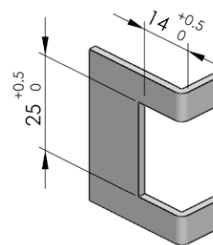
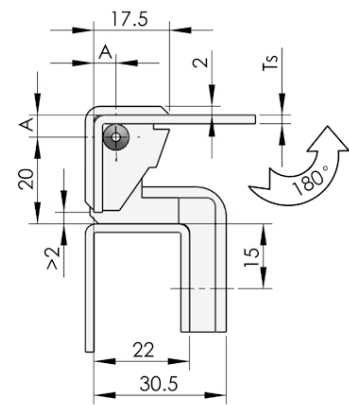
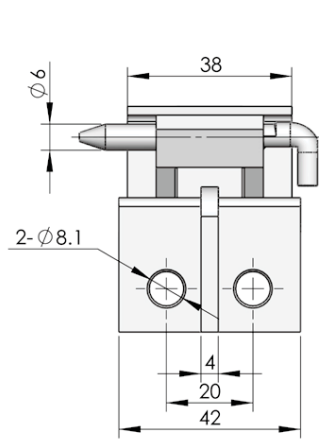

Door cutout

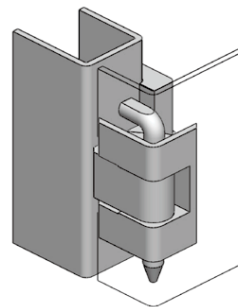

Nylon pin (Optional)

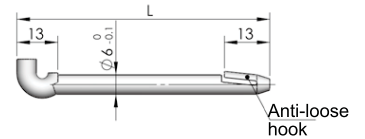

Part No.	L
PN001	57
PN002	78

Model	ERP	Specification	A	Remark
CL255-1	CL255Z1A001	Suitable door thickness Ts=2mm	5.1	ZDC hinge
CL255-2	CL255Z1A002	Suitable door thickness Ts=3mm	6.1	ZDC hinge
CL255-3	CL255Z1A003	Suitable door thickness Ts=1.5mm	4.6	ZDC hinge
CL255-1A	CL255Z1A004	Suitable door thickness Ts=2mm	5.1	Steel female hinge
CL255-2A	CL255Z1A005	Suitable door thickness Ts=3mm	6.1	Steel female hinge
CL255-3A	CL255Z1A006	Suitable door thickness Ts=1.5mm	4.6	Steel female hinge

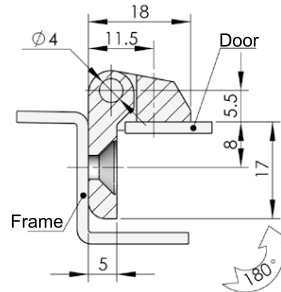
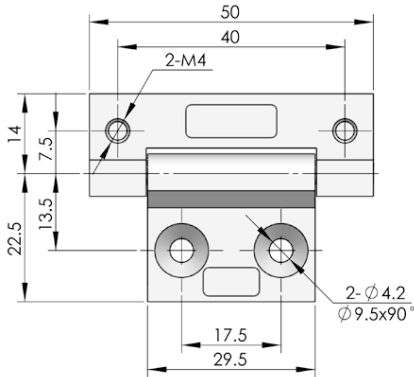

ERP

CL254Z1A001

CL254



Main material and finish: Black powder coated ZDC hinge, nickel plated steel pin
Application: Opening angle 180°

Performance parameter:
Maximum static load
Radial load: 1000N
Axial load: 800N

Accessories

Electronic lock

Handle lock

Cylinder lock

Plane lock

Rod control lock

Panel lock

Toggle and hook

Handles

Door stop

Hinge

Seal gasket

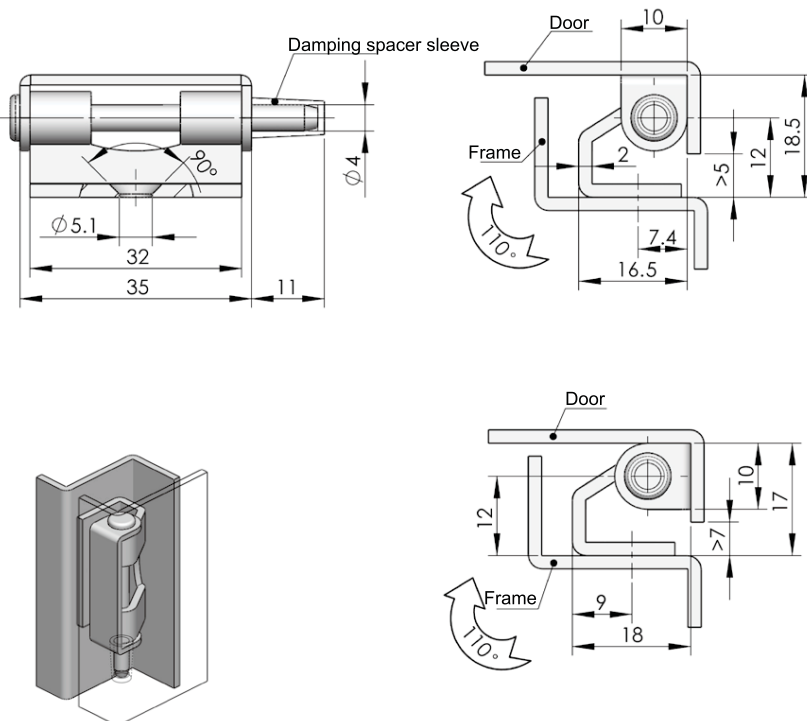

ERP

CL257F3D001

CL257



Main material and finish: White zinc-plated steel hinge and pin, PA spacer sleeve
Application: Opening angle 110°

Performance parameter:
Maximum static load
Radial load: 885N
Axial load: 525N

Accessories
Electronic lock
Handle lock
Cylinder lock
Plane lock
Rod control lock
Panel lock
Toggle and hook
Handles
Door stop
Hinge
Seal gasket



Main material and finish: 3+ zinc plated carbon steel hinge
Application: opening angle 105°

Performance parameter:
Max Static load
Radial load: 130N
Axial Load: 220N

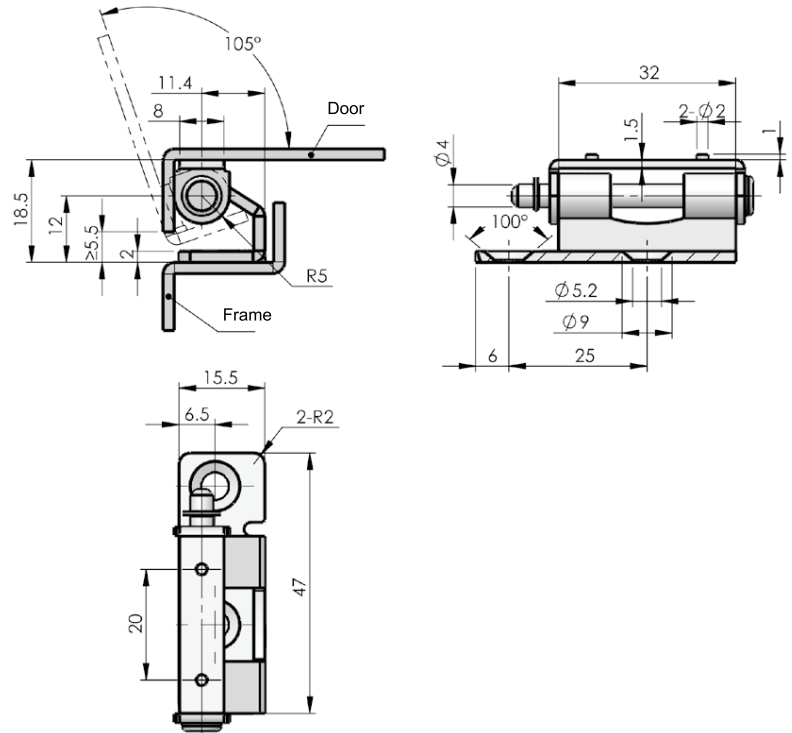

Specification	LH	RH
ERP	CL257F3D009	CL257F3D008



Main material and finish: White zinc-plated steel hinge
Application: Opening angle 120°

Performance parameter:
Maximum static load
Radial load: 350N
Axial load: 205N

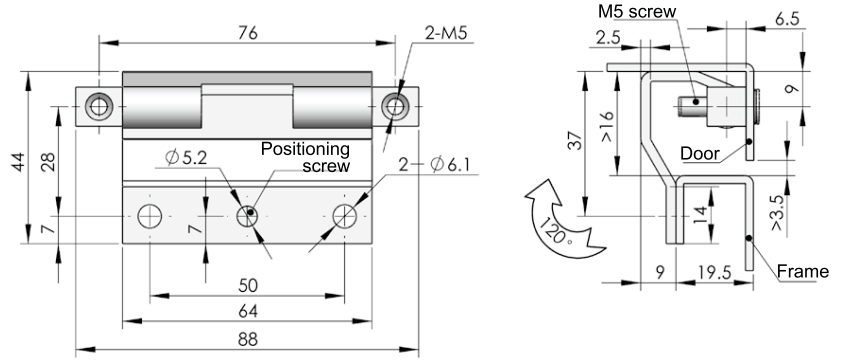

ERP	CL260F3D001
-----	-------------

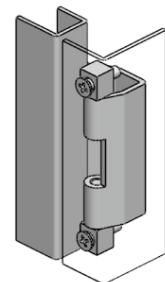

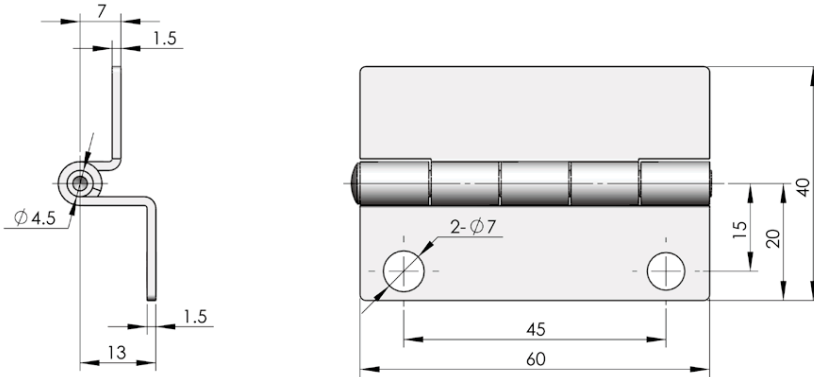

ERP

CL261F3D001

CL261



Main material and finish: White zinc-plated steel hinge
Application: Opening angle 180°

Performance parameter:
Maximum static load
Radial load: 340N
Axial load: 200N

Accessories

Electronic lock

Handle lock

Cylinder lock

Plane lock

Rod control lock

Panel lock

Toggle and hook

Handles

Door stop

Hinge

Seal gasket

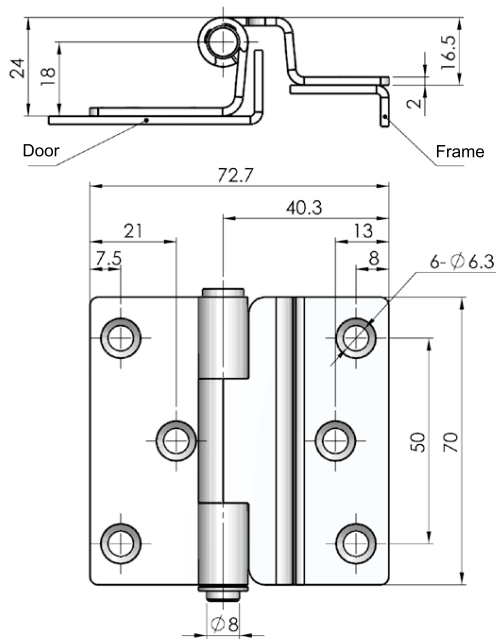

ERP

CL261S9C002

CL261-2



Main material and finish: Electrolysis stainless steel SS304 exposed hinge
Application: Opening angle 180°

Performance parameter:
Maximum static load
Radial load: 600N
Axial load: 400N

- Accessories
- Electronic lock
- Handle lock
- Cylinder lock
- Plane lock
- Rod control lock
- Panel lock
- Toggle and hook
- Handles
- Door stop
- Hinge**
- Seal gasket

CL262



Main material and finish: White zinc-plated steel hinge
Application: Opening angle 120°

Performance parameter:
Maximum static load
Radial load: 430N
Axial load: 650N

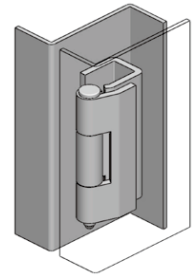
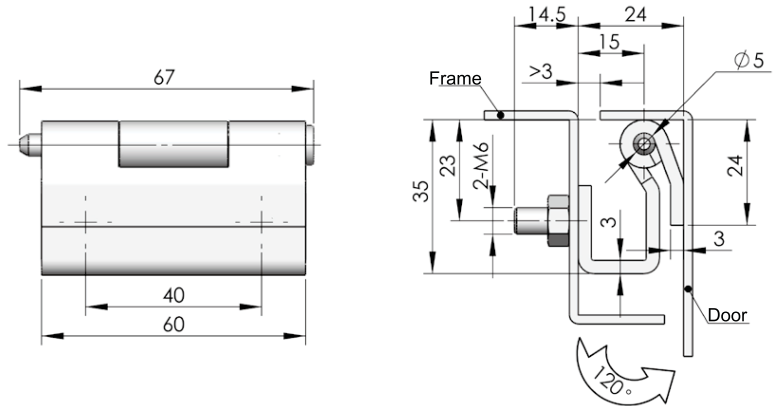

ERP CL262F3D001

CL263



Main material and finish: White zinc-plated steel hinge

Performance parameter:
Maximum static load
Radial load: 1295N
Axial load: /

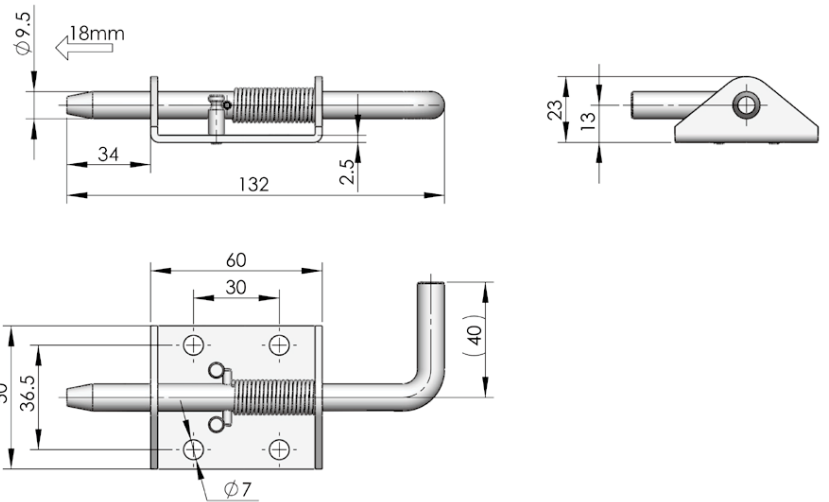

ERP CL263F3D001

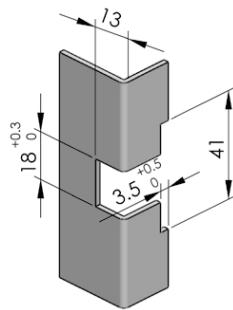
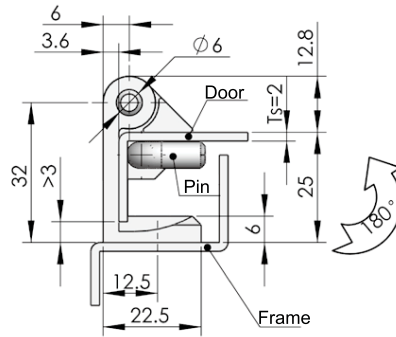
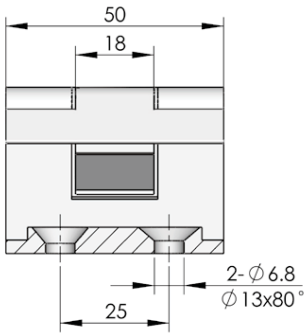

Cut out

ERP

CL264Z1A001

Nylon pin (Optional)

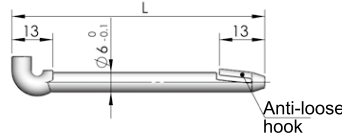

Part No.	L
PN001	57
PN002	78

CL264



Main material and finish: Black powder coated ZDC hinge, stainless steel gasket, nickel plated steel pin
Application: Opening angle 180°

Performance parameter:
Maximum static load
Radial load: 1050N
Axial load: 980N

Accessories

Electronic lock

Handle lock

Cylinder lock

Plane lock

Rod control lock

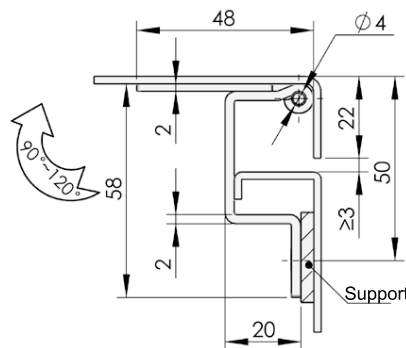
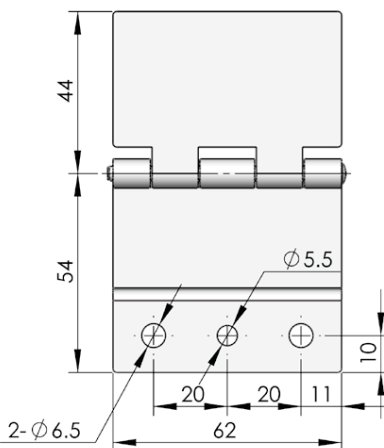

ERP

CL266F3D001

CL266



Main material and finish: White zinc-plated steel hinge

Performance parameter:
Maximum static load
Radial load: 260N
Axial load: 340N

Panel lock

Toggle and hook

Handles

Door stop

Hinge

Seal gasket

- Accessories
- Electronic lock
- Handle lock
- Cylinder lock
- Plane lock
- Rod control lock
- Panel lock
- Toggle and hook
- Handles
- Door stop
- Hinge
- Seal gasket



CL268



INOX
AISI
3..

Main material and finish: Stainless steel or steel hinge

Performance parameter:
Maximum static load
Radial load: 260N
Axial load: 450N

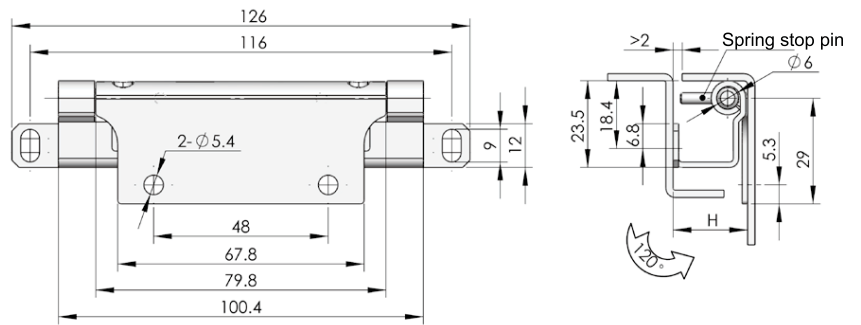

Model	ERP	H	Material
CL268-1	CL268S00001	23.9	Stainless steel
CL268-2	CL268S00002	20.5	Stainless steel
CL268-3	CL268S00003	17.5	Stainless steel
CL268-1A	CL268F3D001	23.9	Steel
CL268-2A	CL268F3D002	20.5	Steel
CL268-3A	CL268F3D003	17.5	Steel



CL269



Main material and finish: White zinc-plated steel hinge

Performance parameter:
Maximum static load
Radial load: 610N
Axial load: 800N

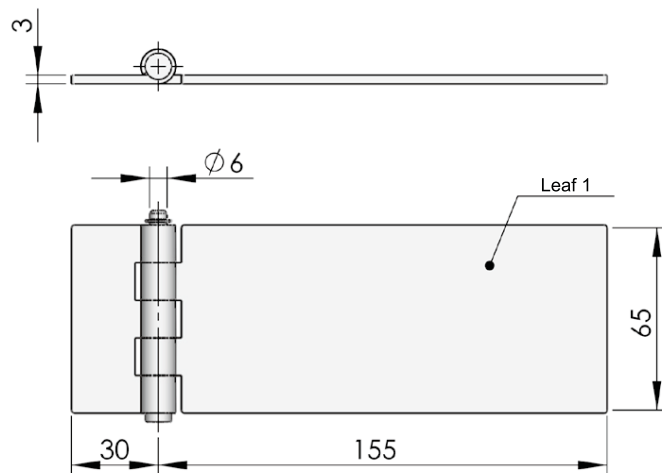

ERP CL269F3D001

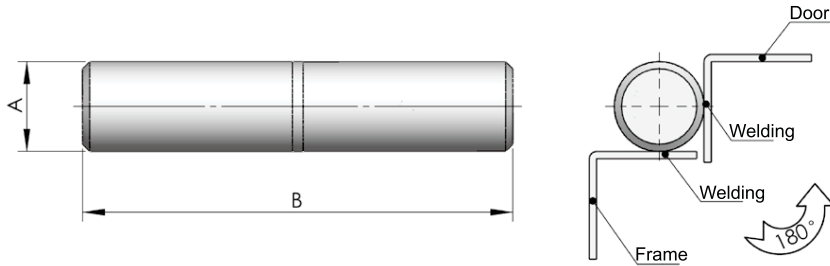

Model	ERP	A	B	C
CL270-1	CL270F3D001	d26	150	75
CL270-2	CL270F3D002	d25	120	60
CL270-3	CL270F3D003	d14	120	60
CL270-4	CL270F3D004	d10	60	30

CL270



Main material and finish: White zinc-plated steel hinge

Performance parameter:
 Maximum static load
 Radial load: 2000N
 Axial load: 2000N

Accessories

Electronic lock

Handle lock

Cylinder lock

Plane lock

Rod control lock

Panel lock

Toggle and hook

Handles

Door stop

Hinge

Seal gasket

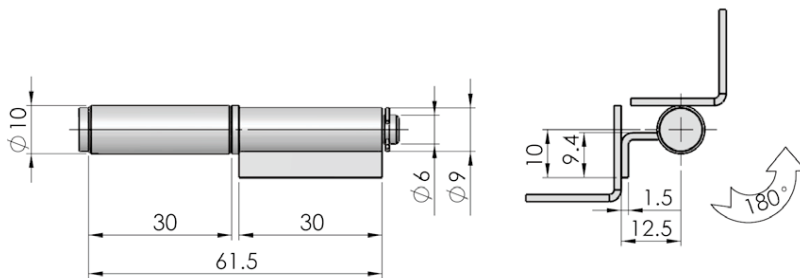

CL270-4-1D



Main material and finish: 3+ zinc plated carbon steel exposed hinge and shaft
 Application: opening angle 180°

Performance parameter:
 Maximum static load
 Radial load: 250N
 Axial load: 150N

ERP CL270F00004

Accessories

Electronic lock

Handle lock

Cylinder lock

Plane lock

Rod control lock

CL272



Main material and finish: Black PA hinge, steel screw, PC shaft
Application: Opening angle 160°

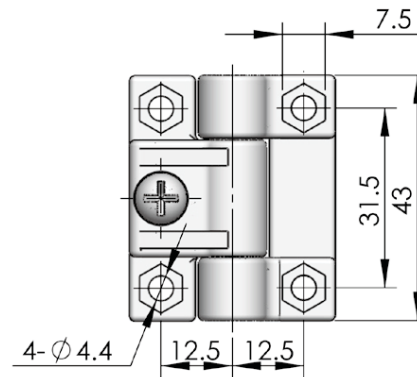
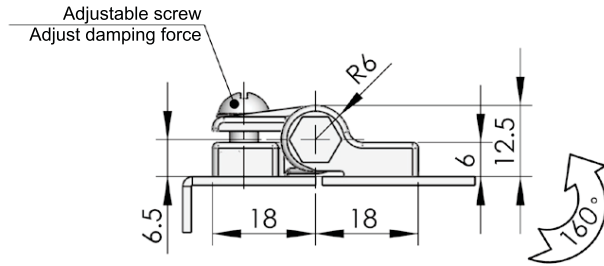

ERP

CL272N00001

Panel lock

Toggle and hook



Handles

Door stop

Hinge

Seal gasket

CL272-2



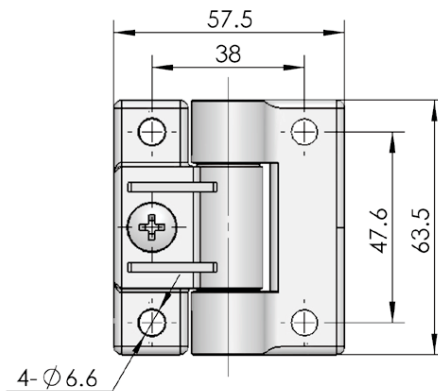
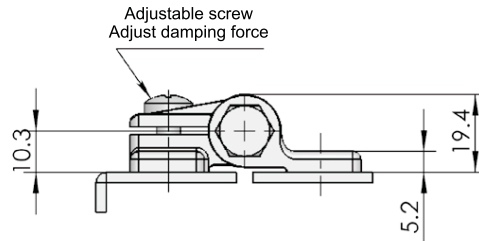

Main material and finish: POM black male and female hinge transparent PC shaft, and Stainless steel adjustable screw and nut.
Application: Maximum rotating angle 165°

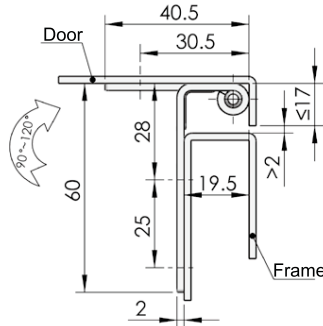
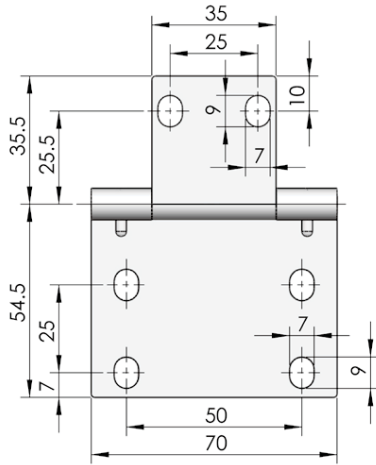

ERP

CL272N00002



ERP

CL273F3D001

CL273



Main material and finish: White zinc-plated steel hinge

Application: Opening angle 90°~120°

Performance parameter:

Maximum static load

Radial load: 260N

Axial load: 340N

Accessories

Electronic lock

Handle lock

Cylinder lock

Plane lock

Rod control lock

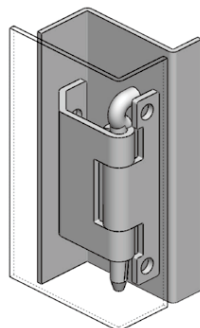
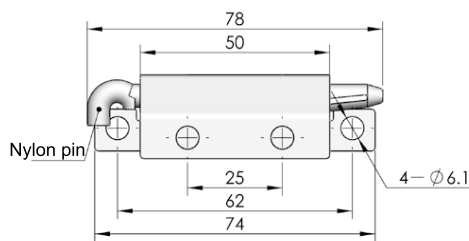
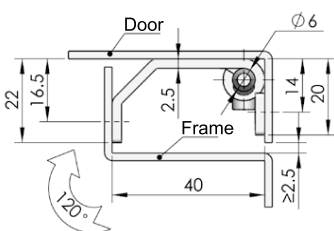

ERP

CL274F3D001

CL274



Main material and finish: White zinc-plated steel hinge

Application: Opening angle 120°

Performance parameter:

Maximum static load

Radial load: 180N

Axial load: 310N

Panel lock

Toggle and hook

Handles

Door stop

Hinge

Seal gasket



Accessories

Electronic lock

Handle lock

Cylinder lock

Plane lock

Rod control lock

Panel lock

Toggle and hook

Handles

Door stop

Hinge

Seal gasket

CL275-1



Main material and finish: White zinc-plated steel hinge
Application: Opening angle 120°

Performance parameter:
Maximum static load
Radial load: 120N
Axial load: 310N

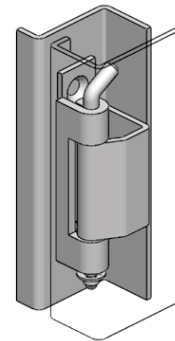
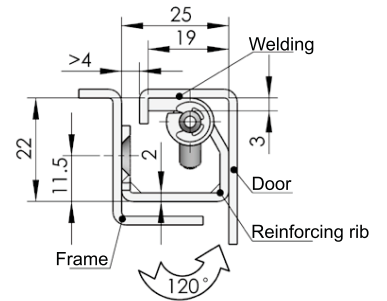
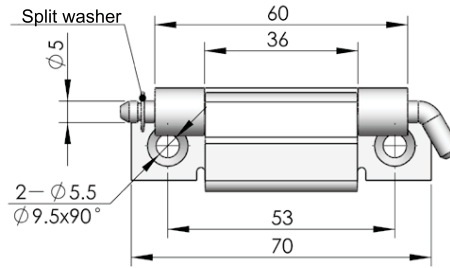

ERP CL275F3D002

CL275-2



Main material and finish: White zinc-plated steel hinge
Application: Opening angle 120°

Performance parameter:
Maximum static load
Radial load: 120N
Axial load: 310N

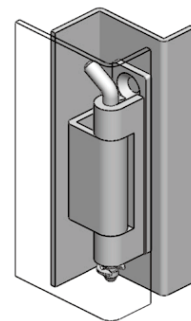
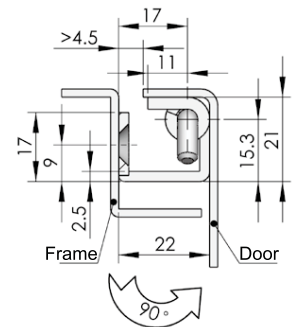
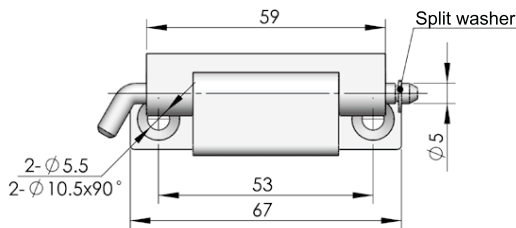

ERP CL275F3D003

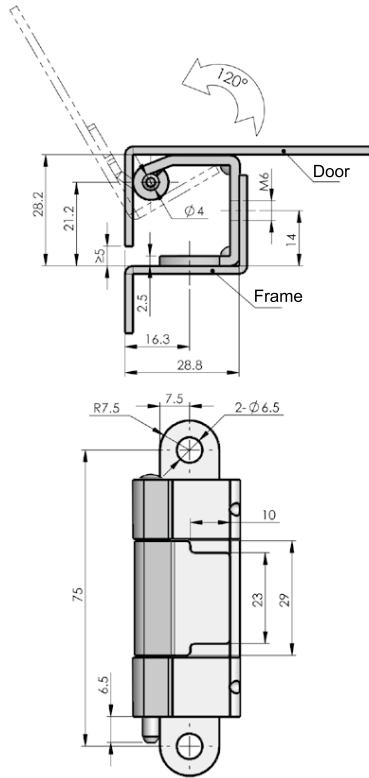

ERP CL275F3D010

CL275-4



Main material and finish: 3+ zinc plated carbon steel hinge
Application: Opening angle 120°

Performance parameter:
Maximum static load
Radial load: 410N
Axial load: 91N

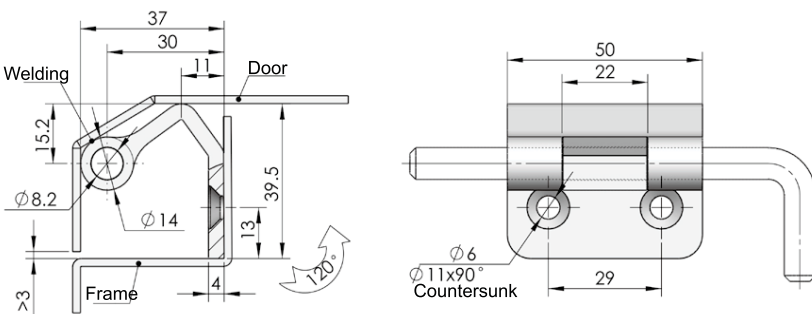

ERP CL276Z3D001

CL276



Main material and finish: White zinc-plated ZDC female hinge
Application: Opening angle 120°

Performance parameter:
Maximum static load
Radial load: 480N
Axial load: 690N

Accessories
Electronic lock
Handle lock
Cylinder lock
Plane lock
Rod control lock
Panel lock
Toggle and hook
Handles
Door stop
Hinge
Seal gasket



Accessories
Electronic lock
Handle lock
Cylinder lock
Plane lock
Rod control lock
Panel lock
Toggle and hook
Handles
Door stop
Hinge
Seal gasket

CL280



Main material and finish: Black powder coated steel female hinge, white zinc-plated pin

Application: Opening angle 120°

Performance parameter:

Maximum static load

Radial load: 360N

Axial load: 105N

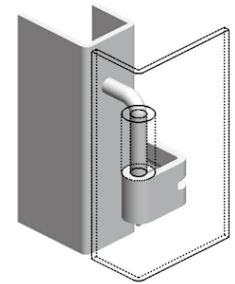
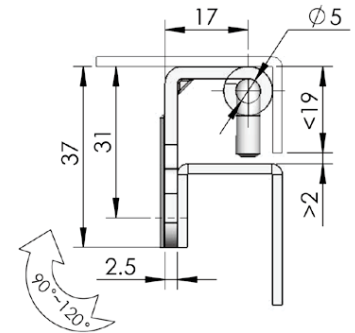
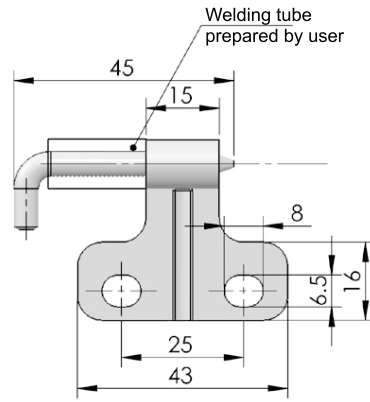

ERP CL280F1A001

CL280-2



Main material and finish: Black powder coated steel female hinge, male hinge blank, white zinc-plated shaft

Application: Opening angle 120°

Performance parameter:

Maximum static load

Radial load: 1220N

Axial load: 1000N

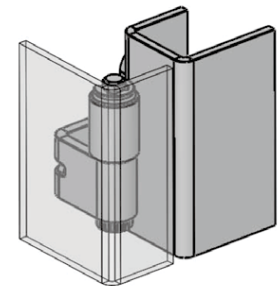
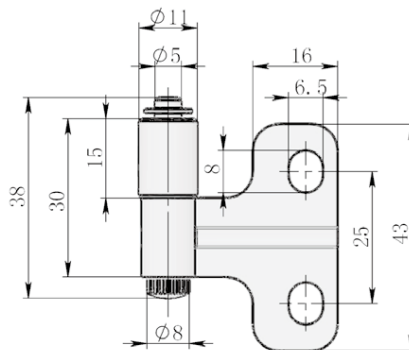
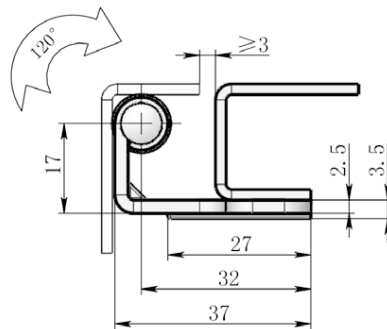

ERP CL280F2A003

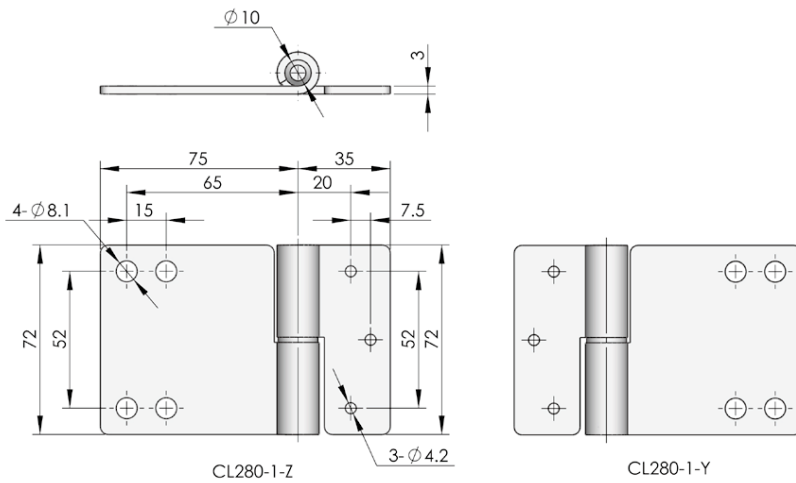

	CL281-A-Z LH	CL281-A-Y RH
ERP	CL281S4A001	CL281S4A003

CL281



Main material and finish: Stainless steel hinge

Application: Opening angle 180°

Performance parameter:

Maximum static load

Radial load: 1280N

Axial load: 630N

Accessories

Electronic lock

Handle lock

Cylinder lock

Plane lock

Rod control lock

Panel lock

Toggle and hook

Handles

Door stop

Hinge

Seal gasket

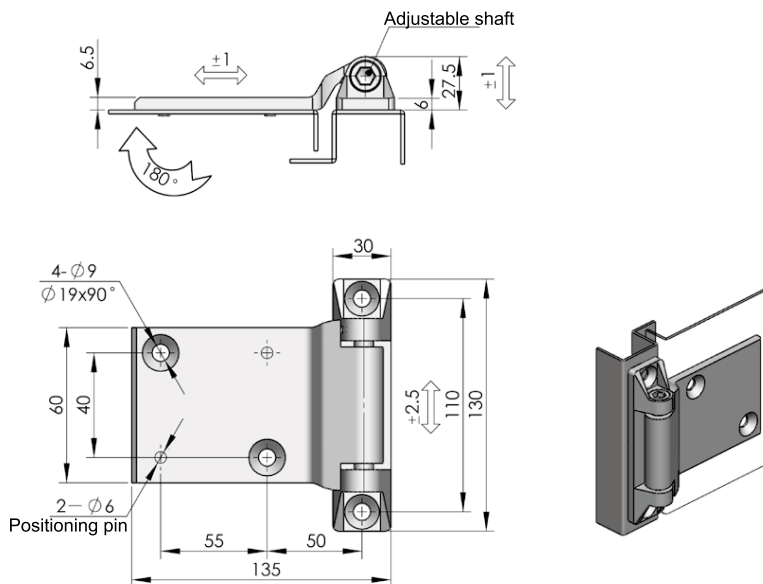

	CL282-1-Z LH	CL282-1-Y RH
ERP	CL282Z1B001	CL282Z1B002

CL282-1-Y CL282-1-Z



Main material and finish: Pocked black powder coated ZDC female part, stainless steel shaft

Application: Opening angle 180°

Performance parameter:

Maximum static load

Radial load: 1800N

Axial load: 1500N

- Accessories
- Electronic lock
- Handle lock
- Cylinder lock
- Plane lock
- Rod control lock
- Panel lock
- Toggle and hook
- Handles
- Door stop
- Hinge
- Seal gasket

CL282-2-Y
CL282-2-Z



Main material and finishing: Pocked black powder coated ZDC female hinge, stainless steel shaft
Application: Opening angle 180°

Performance parameter:
Maximum static load
Radial load: 1500N
Axial load: 1300N

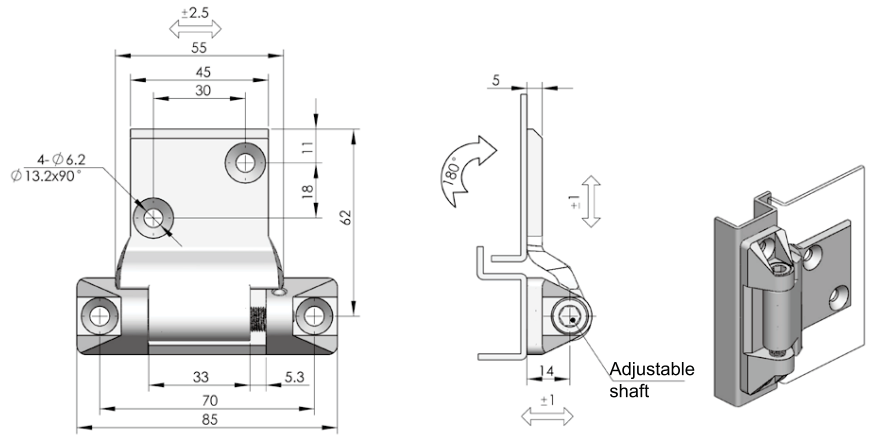

	CL282-2-Z LH	CL282-2-Y RH
ERP	CL282Z1B003	CL282Z1B004

CL283-4



INOX
AISI
3..

Main material and finishing: Stainless steel hinge and pin
Application: Opening angle 140°

Performance parameter:
Maximum static load
Radial load: 500N
Axial load: 980N

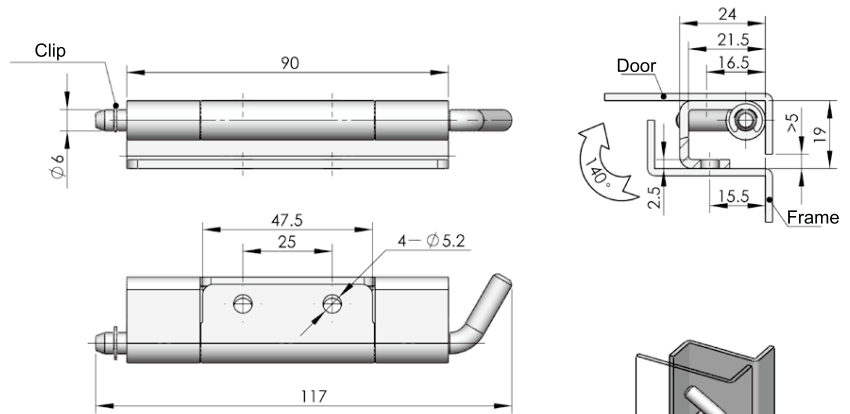

ERP	CL283S00003
-----	-------------

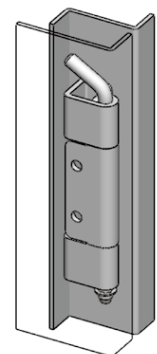

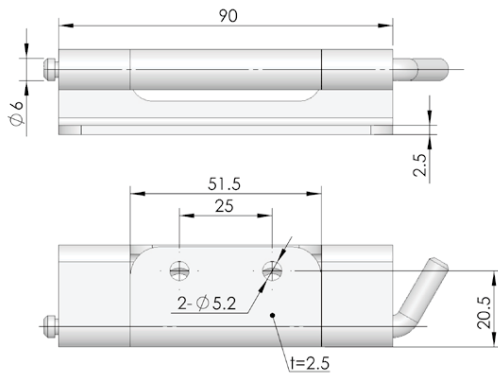

CL283-1

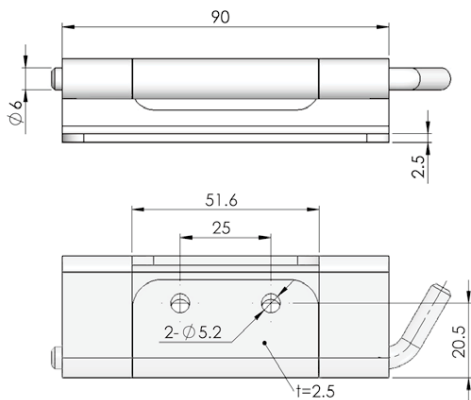
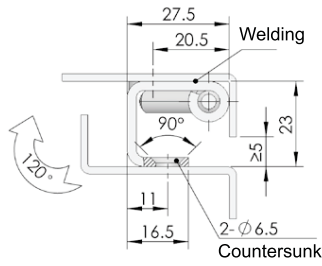

CL283-2

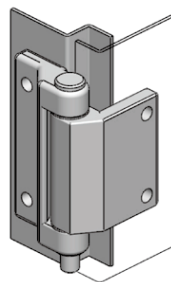
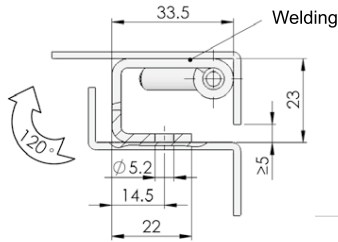

CL283-1
CL283-2



INOX
AISI
3..

Main material and finish: stainless steel
hinge and shaft
Application: Opening angle 120°

Performance parameter:
Maximum static load
Radial load: 500N
Axial load: 980N

Accessories

Electronic lock

Handle lock

Cylinder lock

Plane lock

Rod control lock

Panel lock

Toggle and hook

Handles

Door stop

Hinge

Seal gasket

	CL283-1	CL283-2
ERP	CL283S00001	CL283S00002

CL283-8



NEW



INOX
AISI 304

Main material and finish: Zinc nickel alloy steel hinge
Application: Opening angle 130°

Performance parameter:
Maximum static load
Radial load: 240N
Axial load: 330N

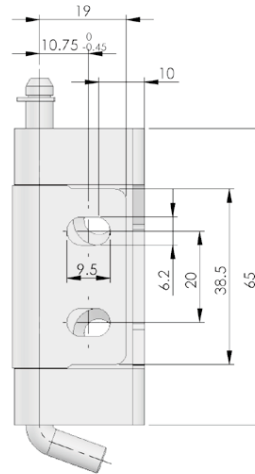
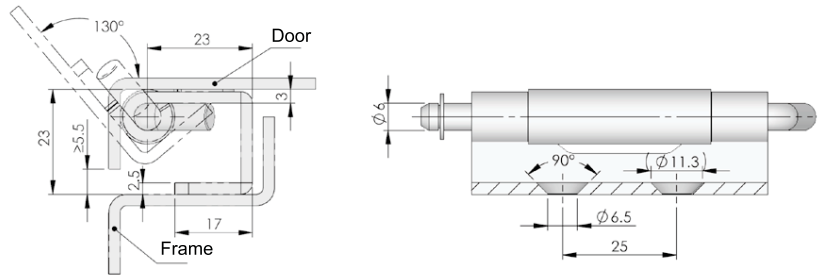

Accessories
Electronic lock
Handle lock
Cylinder lock
Plane lock
Rod control lock



ERP

CL283F3D006

CL288





INOX
AISI 304

Main material and finish: Stainless steel hinge
Application: Opening angle 180°

Performance parameter:
Maximum static load
Radial load: 3000N
Axial load: 3000N

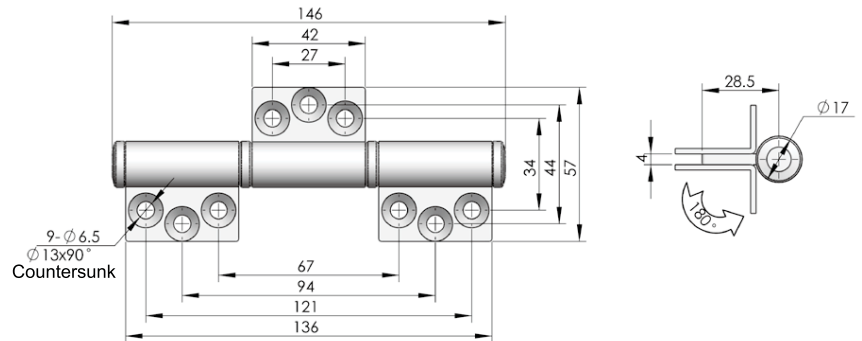
Panel lock
Toggle and hook
Handles
Door stop
Hinge
Seal gasket



ERP

CL288S00001

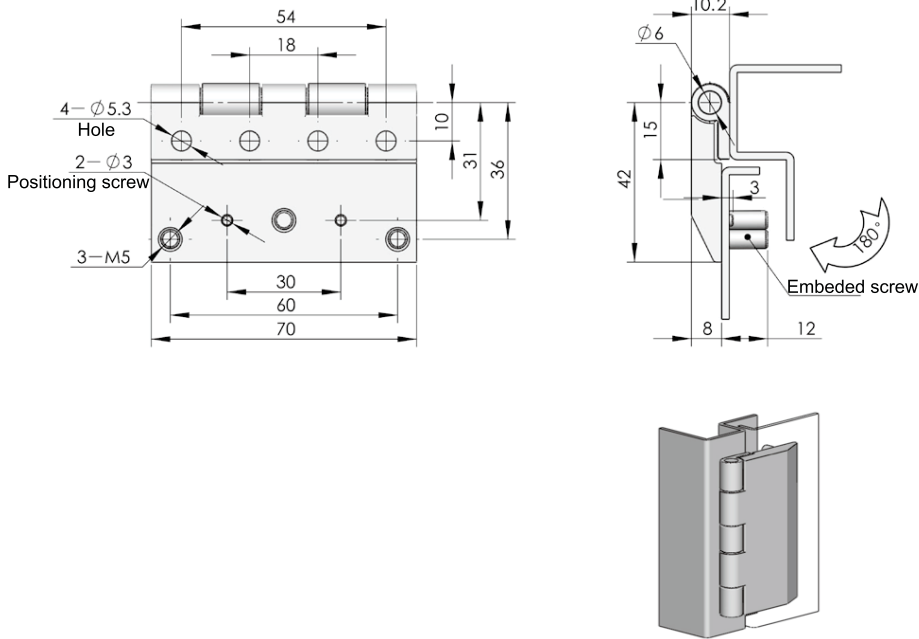

ERP

CL289Z2A001

CL289



Main material and finish: Black painted ZDC female part
Application: Opening angle 180°

Performance parameter:
Maximum static load
Radial load: 1500N
Axial load: 1435N
Embedded screw recommended tightening torque: 10N. m

Accessories

Electronic lock

Handle lock

Cylinder lock

Plane lock

Rod control lock

CL289-2

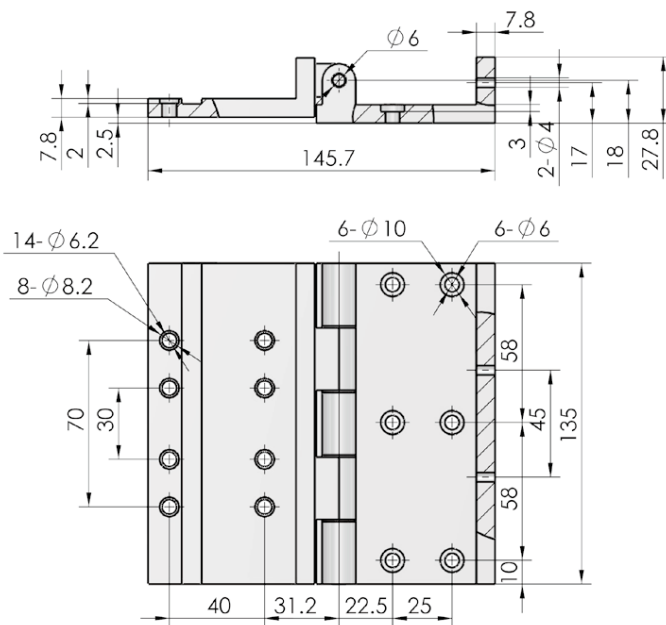

ERP

CL289A2B001

Main material and finish: Painted aluminium alloy
Application: Opening angle 180°

Performance parameter:
Maximum static load
Radial load: 1000N
Axial load: 1000N

Panel lock

Toggle and hook

Handles

Door stop

Hinge

Seal gasket

Accessories

Electronic lock

Handle lock

Cylinder lock

Plane lock

Rod control lock

CL290

Main material and finish: Stainless steel hinge
Application: Opening angle 110°

Performance parameter:
Maximum static load
Radial load: 140N
Axial load: 310N

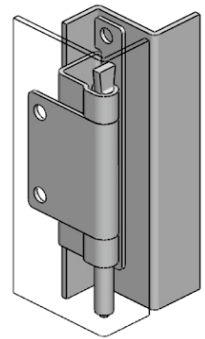
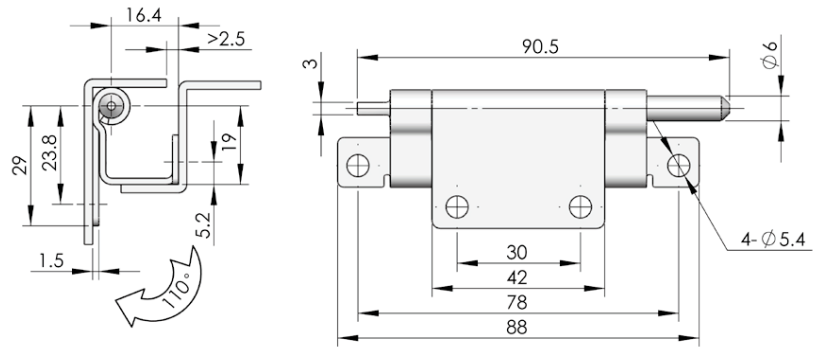

ERP CL290S00001

Panel lock

Toggle and hook

Handles

Door stop

CL292

Main material and finish: Sand-spraying and chrome-plated ZDC hinge, carbon steel pin
Application: Opening angle 180°

Performance parameter:
Maximum static load
Radial load: 95N
Axial load: 105N

Hinge

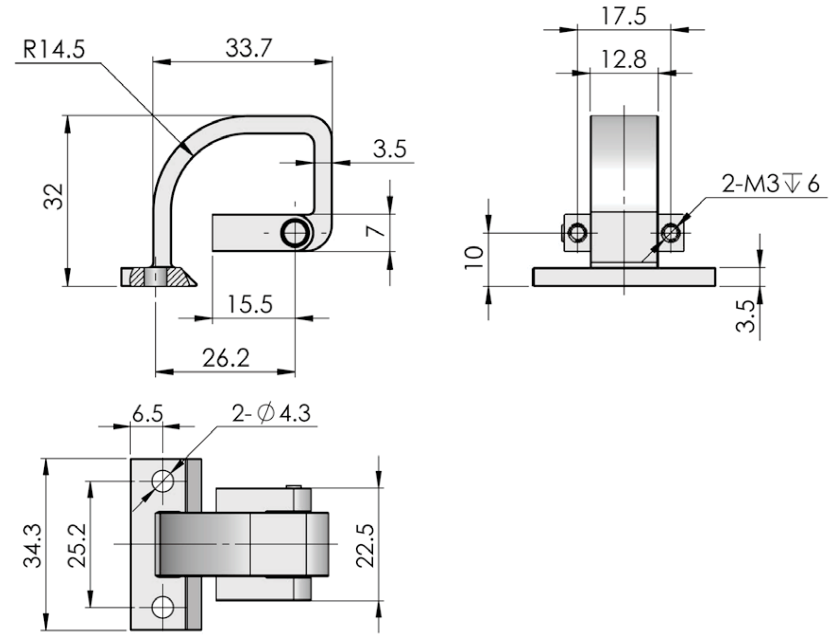

ERP CL292Z3H001

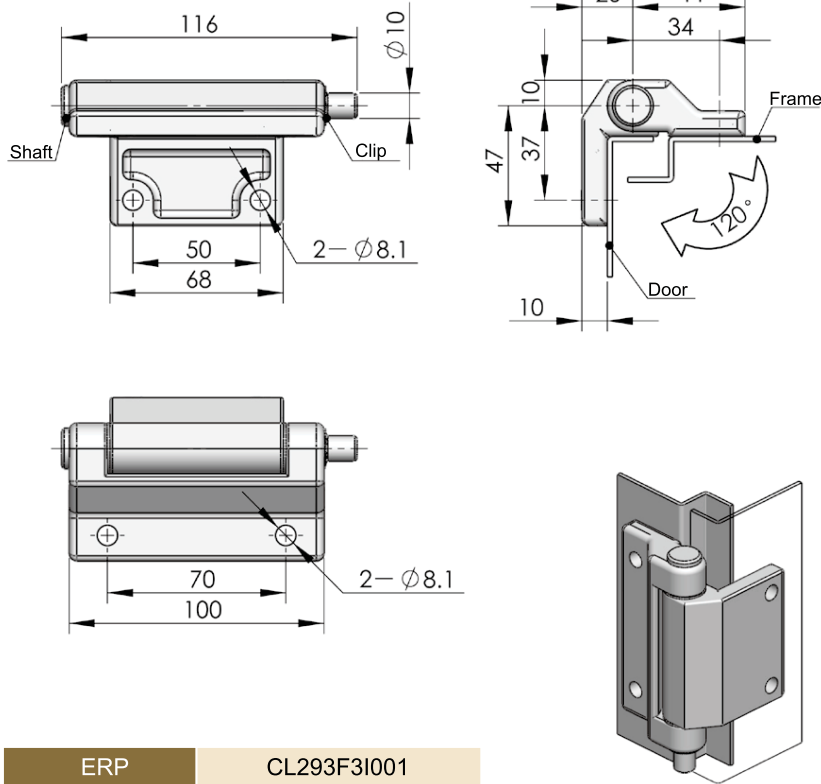

ERP

CL293F31001

CL293



Main material and finish: Sand-spraying and nickel-plated casting steel hinge
Application: Opening angle 120°

Performance parameter:
Maximum static load
Radial load: 3000N
Axial load: 3000N

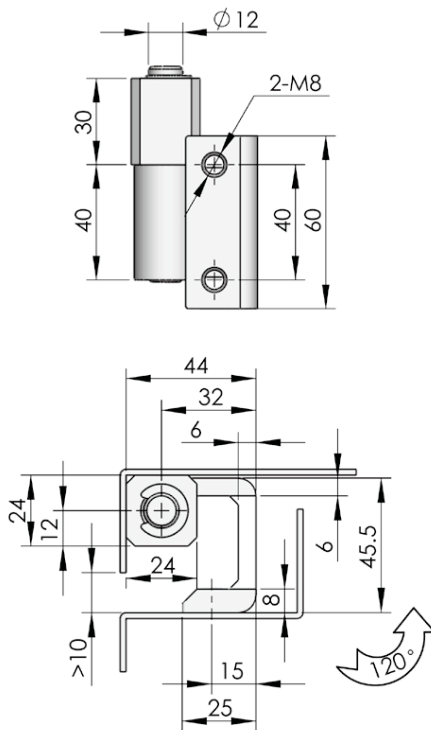

ERP

CL294S00001

CL294



INOX
AISI
3..

Main material and finish: Stainless steel hinge
Application: Opening angle 120°

Performance parameter:
Maximum static load
Radial load: 2000N
Axial load: 1500N

Accessories

Electronic lock

Handle lock

Cylinder lock

Plane lock

Rod control lock

Panel lock

Toggle and hook

Handles

Door stop

Hinge

Seal gasket

Accessories

Electronic lock

Handle lock

Cylinder lock

Plane lock

Rod control lock

CL295

Main material and finish: Black PA hinge, white zinc plated steel pin
Application: Opening angle 180°

Performance parameter:
Maximum static load
Radial load: 1180N
Axial load: 1515N

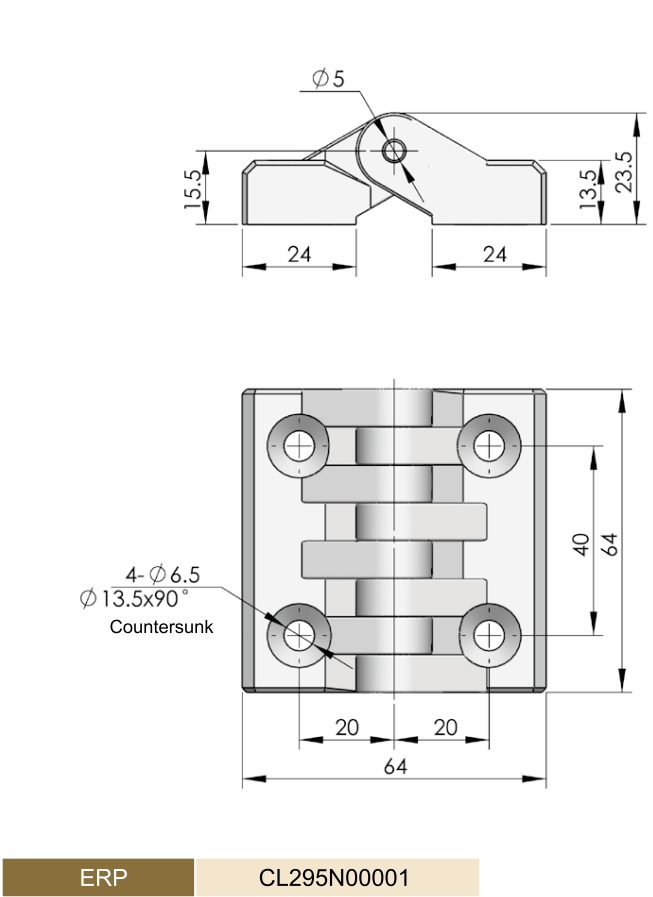

Panel lock

Toggle and hook

Handles

Door stop

Hinge

Seal gasket

CL296

Main material and finish: White zinc-plated steel hinge
Application: Opening angle 120°

Performance parameter:
Maximum static load
Radial load: 200N
Axial load: 160N

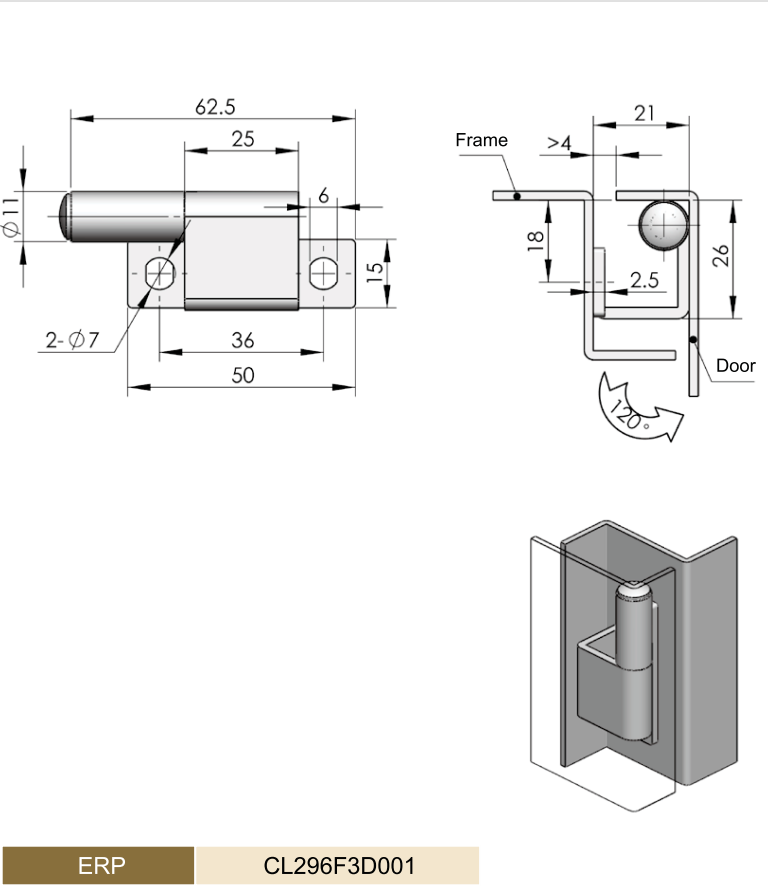

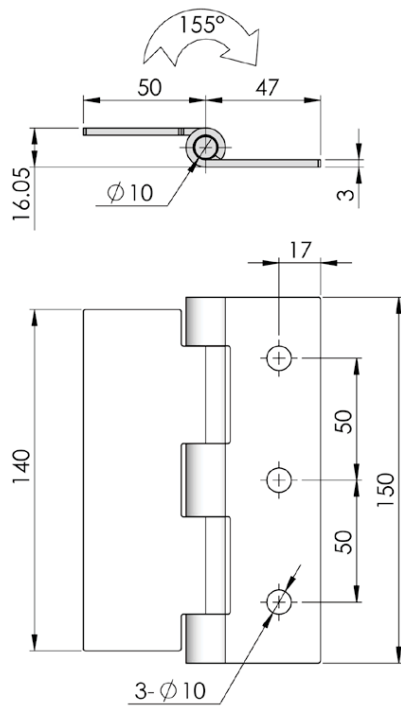

ERP CL297F00001

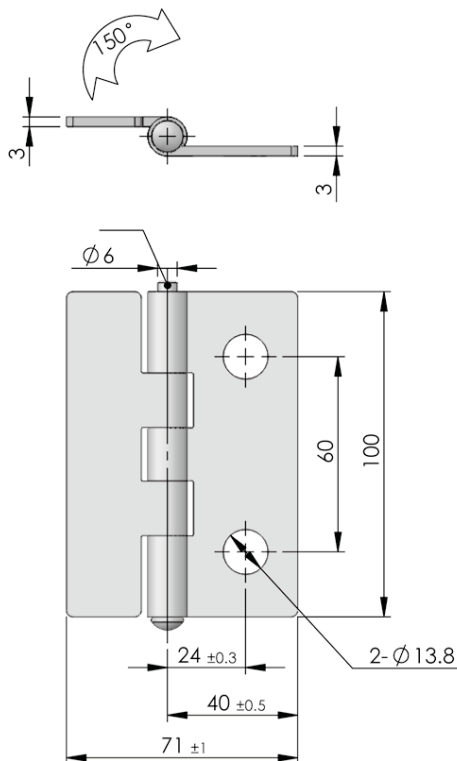

ERP CL297F00002

CL297



Main material and finish: Antirust oil soaked steel hinge
 Application: Opening angle 155°

Performance parameter:
 Maximum static load
 Radial load: 1500N
 Axial load: 1800N

CL297-2



Main material and finish: Antirust oil soaked steel hinge leaf, stainless steel pin
 Application: Opening angle 150°

Performance parameter:
 Maximum static load
 Radial load: 900N
 Axial load: 2000N

- Accessories
- Electronic lock
- Handle lock
- Cylinder lock
- Plane lock
- Rod control lock
- Panel lock
- Toggle and hook
- Handles
- Door stop
- Hinge
- Seal gasket

Accessories

CL331



Electronic lock

Handle lock



Main material and finish: Nanometer painted ZDC hinge and nickel plated steel pin

Application: Opening angle 90°

Cylinder lock

Plane lock

Performance parameter:
Maximum static load
Radial load: 260N
Axial load: 330N

Rod control lock

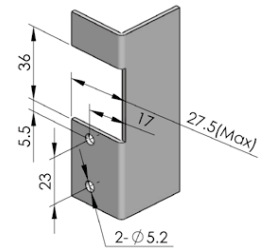
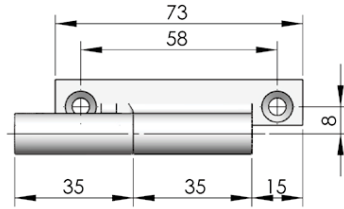
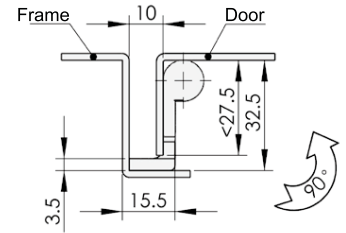
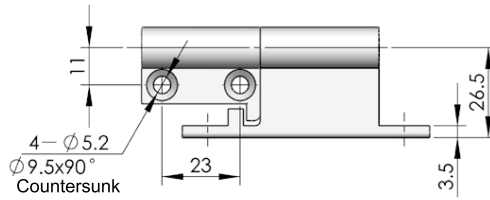

Door cutout

	Nanometer painted	Black powder coated
ERP	CL331Z2B001	CL331Z1A001

Panel lock

CL332



Toggle and hook

Handles



Main material and finish: Black powder coated ZDC hinge and nicked plated steel pin

Application: Opening angle 90°

Door stop

Hinge

Performance parameter:
Maximum static load
Radial load: 295N
Axial load: 625N

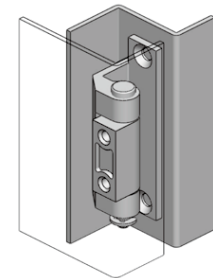
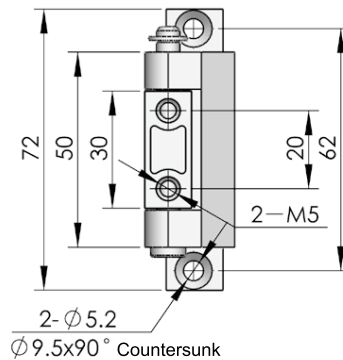
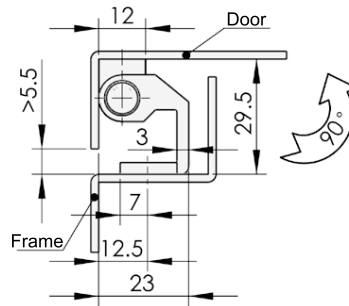

	Nanometer painted	Black powder coated
ERP	CL332Z2B001	CL332Z1A001

Seal gasket